

 megius®

MILLE
EMOZIONANTI
GOCCHE
IN **U**NO
SPAZIO

PORTFOLIO 48|24

inox



lotus
p. 4



axer
p. 12

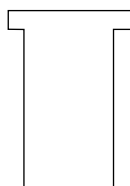

icona
p. 20

separè



materia
p. 30

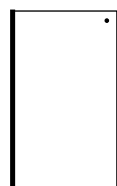

solodoccia
p. 40

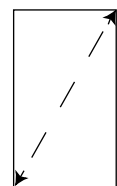

mur
p. 48



eter
p. 62



vitros
p. 74



mariposa
p. 82



lux
p. 88

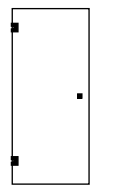

detail
p. 94



icona
p. 20

frameless

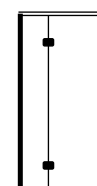

sofist
p. 102



stile libero
p. 112



prisma 1.0
p. 120

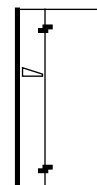

prisma 2.0
p. 130

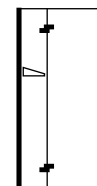

web series
1.0
p. 138



web series
1.1
p. 138

frame

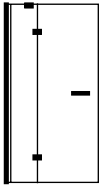

web series
2.0
p. 138

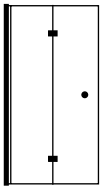

web series
3.0
p. 138

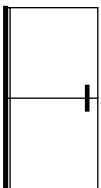

web series
5.0
p. 138

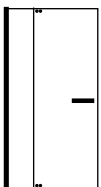

solodoccia
evo pivot
p. 164

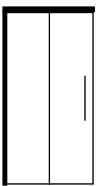

solodoccia
sliding
p. 152

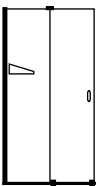

illusion
p. 186

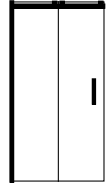

light
p. 178

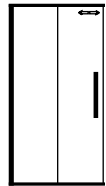

zen XL
p. 198

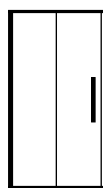

zen
p. 206

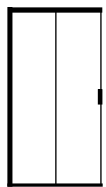

more live
p. 224

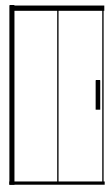

live top
p. 232

furniture

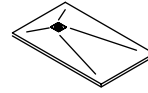

Technart
Planus
Corian
p. 240



eclipse
p. 246

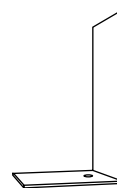

doiserie
p. 260



LOTUS









La doccia battente in inox è per sempre
The stainless steel shower is forever
La ducha de acero inoxidable es para siempre
La douche en acier inoxydable est pour toujours
Die Edelstahldusche ist für immer

lotus



La doccia battente in inox è per sempre
The stainless steel shower is forever
La ducha de acero inoxidable es para siempre
La douche en acier inoxydable est pour toujours
Die Edelstahldusche ist für immer

INOX | PIVOT

VETRI TEMPERATI / TEMPERED GLASSES / CRISTAL TEMPLADO VERRES TREMPÉS / GETEMPERTE GLÄSER

 trasparente - transparent transparent - transparente klarglas F	 MOSAIC CROM C
 opaline - opaline opalin - opaco - opalglas H	 serigraf. MOSAIC WHITE Serigrafado MOSAIC WHITE W
 fumè - rauchglas humo - fumado N	 serigraf. LINE - LINE serigr. LINE Serigrafado - LINE siebdruck V
 serigraf. STRIPE - STRIPE serigr. STRIPE siebdruck - serigraf. STRIPE - STRIPE serigr. J	

PROFILI / PROFILES PERFILES / PROFILS / PROFILEN

 acciaio lucido - Shining steel acero brillante - acier brillant - Stahl glänzend
 Acciaio satinato - Brushed steel - acero cepillado Acier brossé - Gebürstetem Stahl

ALTEZZA STANDARD STANDARD HEIGHT ALTURA ESTÁNDAR STANDARD HÖHE HAUTEUR STANDARD	h. 2000 mm
SPESSORE DEI VETRI GLASS THICKNESS ESPESOR DE VIDRIO GLASDICKE ÉPAISSEUR DU VERRE	6 mm
ALTEZZA DELLA MANIGLIA HANDLE HEIGHT ALTURA DE LA MANIJA HANDGRIFF HÖHE HAUTEUR DE LA POIGNÉE	320 mm
TRATTAMENTO PROTECTIVE PROTECTIVE TREATMENT TRATAMIENTO PROTECTOR PROTECTIVE BEHANDLUNG TRAITEMENT PROTECTIVE	INCLUDED

**MODELLI / MODELS / MODELOS
MODÈLES / MODELLE**

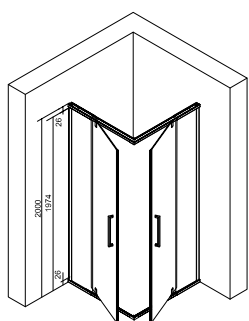

LOTUS A 1/2

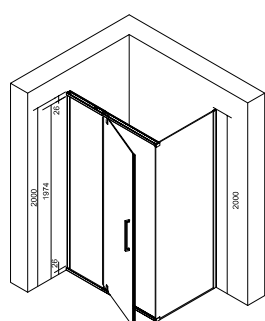

LOTUS A1B + FB

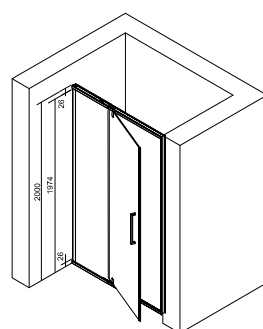

LOTUS B1F

**COMBINAZIONI / COMBINATIONS
COMBINACIONES / COMBINAISONS / KOMBINATIONEN**

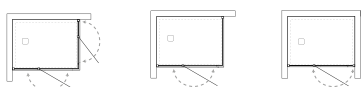

**PROFILI A MURO / WALL PROFILE / PERFIL DE PARED
PROFILÉS MURAUX / WANDPROFIL**

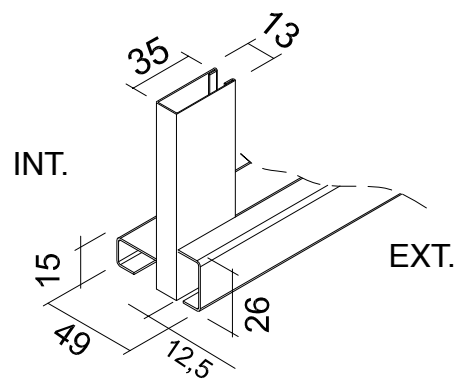







LOTUS BIF





AXXER









La doccia scorrevole in inox è per sempre
The sliding stainless steel shower is forever
La ducha corredera de acero inoxidable es para siempre
La douche coulissante en acier inoxydable est éternelle
Die Edelstahlschiebedusche ist für immer

axer



La doccia scorrevole in inox è per sempre
The sliding stainless steel shower is forever
La ducha corredera de acero inoxidable es para siempre
La douche coulissante en acier inoxydable est éternelle
Die Edelstahlschiebedusche ist für immer

INOX SLIDING

VETRI TEMPERATI / TEMPERED GLASSES / CRISTAL TEMPLADO VERRES TREMPÉS / GETEMPERTE GLÄSER

 trasparente - transparent transparent - transparente klarglas F	 MOSAIC CROM C
 opaline - opaline opalin - opaco - opalglas H	 serigraf. MOSAIC WHITE Serigrafado MOSAIC WHITE W
 fumè - rauchglas humo - fumado N	 serigraf. LINE - LINE serigr. LINE Serigrafado - LINE siebdruck V
 serigraf. STRIPE - STRIPE serigr. STRIPE siebdruck - serigraf. STRIPE - STRIPE serigr. J	

PROFILI / PROFILES PERFILES / PROFILS / PROFILEN

 acciaio lucido - Shining steel acero brillante - acier brillant - Stahl glänzend
 Acciaio satinato - Brushed steel - acero cepillado Acier brossé - Gebürstetem Stahl

ALTEZZA STANDARD STANDARD HEIGHT ALTURA ESTÁNDAR STANDARD HÖHE HAUTEUR STANDARD	h. 2000 mm
SPESSORE DEI VETRI GLASS THICKNESS ESPESOR DE VIDRIO GLASDICKE ÉPAISSEUR DU VERRE	6 + 8 mm
ALTEZZA DELLA MANIGLIA HANDLE HEIGHT ALTURA DE LA MANIJA HANDGRIFF HÖHE HAUTEUR DE LA POIGNÉE	160 mm
TRATTAMENTO PROTECTIVE PROTECTIVE TREATMENT TRATAMIENTO PROTECTOR PROTECTIVE BEHANDLUNG TRAITEMENT PROTECTIVE	INCLUDED

**MODELLI / MODELS / MODELOS
MODÈLES / MODELLE**

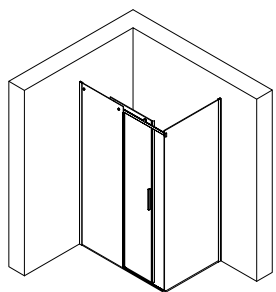

AXER P1S + FS

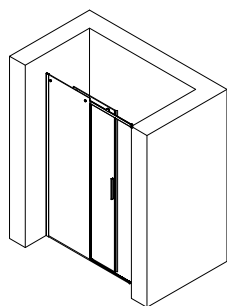

AXER P1S

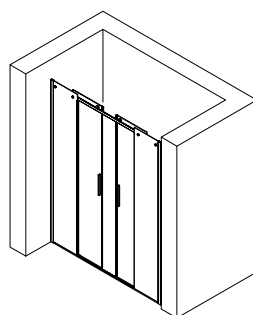

AXER P2S

**COMBINAZIONI / COMBINATIONS
COMBINACIONES / COMBINAISONS / KOMBINATIONEN**

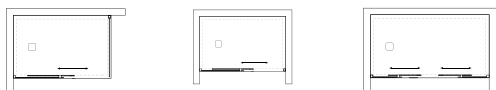

**PROFILI A MURO / WALL PROFILE / PERFIL DE PARED
PROFILÉS MURAUX / WANDPROFIL**

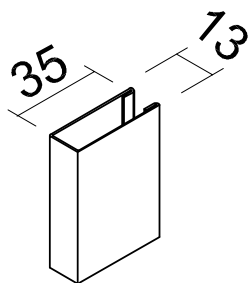



AXER P1S+FS



AXER PIS+FSO







ICONIA



L'incastro perfetto tra lastre di vetro
The perfect union between glass plates
La unión perfecta entre placas de vidrio
Le joint parfait entre les plaques de verre
Die perfekte Verbindung zwischen Glasplatten

icona

L'incastro perfetto tra lastre di vetro
The perfect union between glass plates
La unión perfecta entre placas de vidrio
Le joint parfait entre les plaques de verre
Die perfekte Verbindung zwischen Glasplatten

INOX - SEPARÈ

VETRI TEMPERATI / TEMPERED GLASSES / CRISTAL TEMPLADO VERRES TREMPÉS / GETEMPERTE GLÄSER



trasparente - transparent
transparent - transparente klarglas
F



fumè - rauchglas
humo - fumado
N



extra chiaro - extra clear
extraclair - extraclaro - extra claro
Q

PROFILI / PROFILES PERFILES / PROFILS / PROFILEN



acciaio lucido - Shining steel
acero brillante - acier brillant - Stahl glänzend



Acciaio satinato - Brushed steel - acero cepillado
Acier brossé - Gebürstetem Stahl

ALTEZZA STANDARD STANDARD HEIGHT ALTURA ESTÁNDAR STANDARD HÖHE HAUTEUR STANDARD	h. 2160 mm
SPESSORE DEI VETRI GLASS THICKNESS ESPESOR DE VIDRIO GLASDICKE ÉPAISSEUR DU VERRE	8 mm
ALTEZZA DELLA MANIGLIA HANDLE HEIGHT ALTURA DE LA MANIJA HANDGRIFF HÖHE HAUTEUR DE LA POIGNÉE	/
TRATTAMENTO PROTECTIVE PROTECTIVE TREATMENT TRATAMIENTO PROTECTOR PROTECTIVE BEHANDLUNG TRAITEMENT PROTECTIVE	INCLUDED

MODELLI / MODELS / MODELOS
MODÈLES / MODELLE

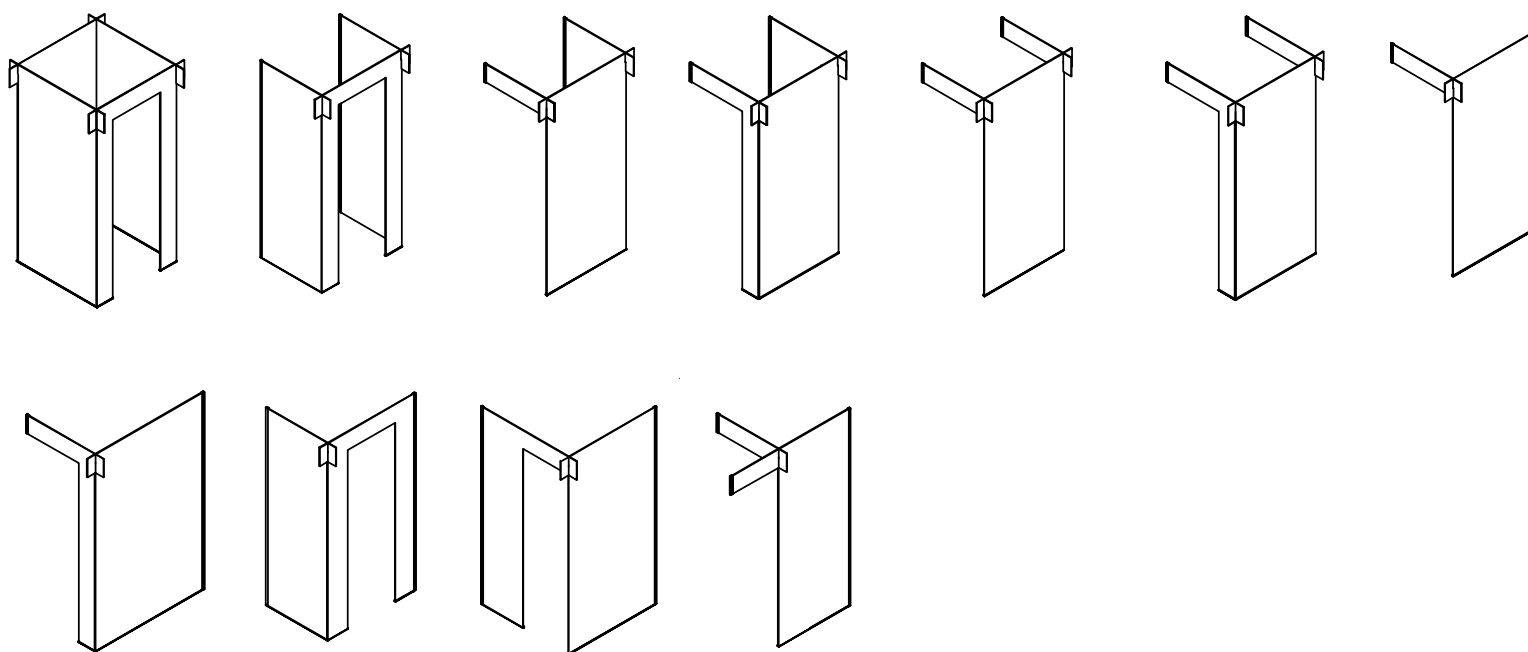

COMBINAZIONI / COMBINATIONS
COMBINACIONES / COMBINAISONS / KOMBINATIONEN

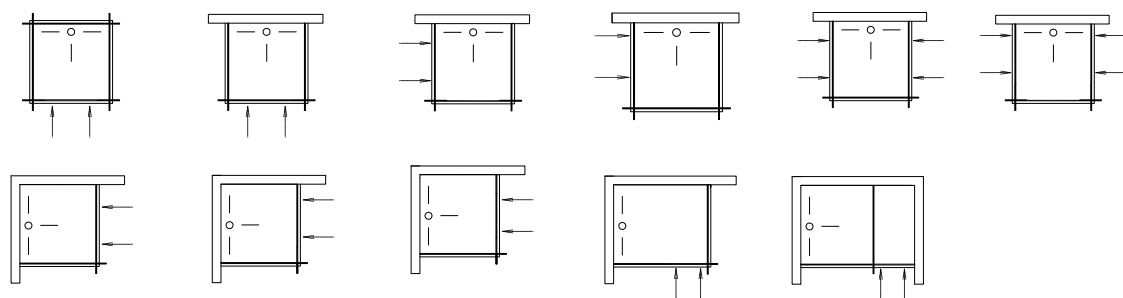





ICONA G+E/F







ICONA G+E/F



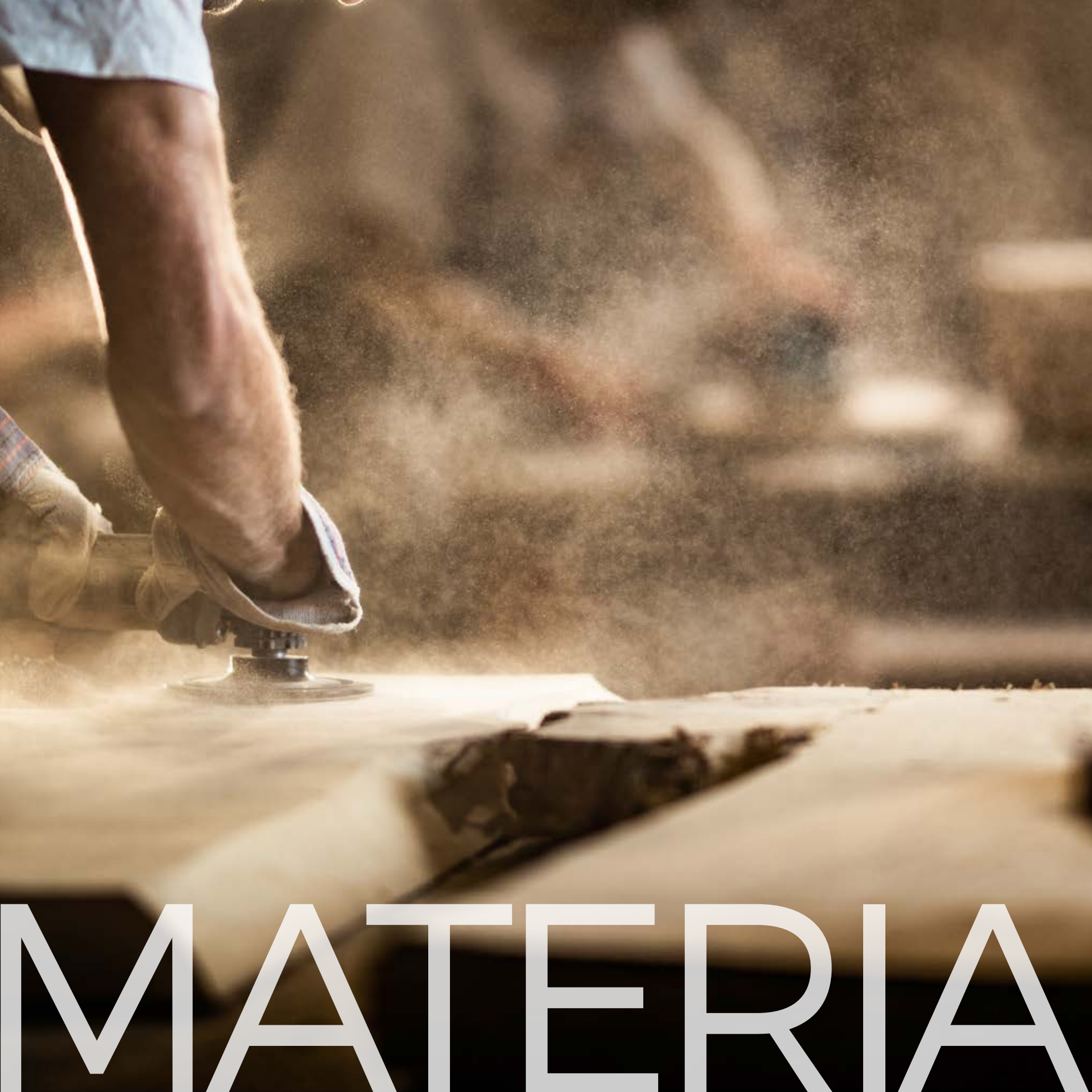

MATERIA



La doccia, connubio tra più materiali
The shower, a combination of several materials
La ducha, una combinación de varios materiales
La douche, une combinaison de plusieurs matériaux
Die Dusche, eine Kombination aus mehreren Materialien

materia

La doccia, connubio tra più materiali
The shower, a combination of several materials
La ducha, una combinación de varios materiales
La douche, une combinaison de plusieurs matériaux
Die Dusche, eine Kombination aus mehreren Materialien

SEPARÈ

VETRI TEMPERATI / TEMPERED GLASSES / CRISTAL TEMPLADO VERRES TREMPÉS / GETEMPERTE GLÄSER



trasparente - transparent
transparent - transparente - klarglas

F



serigraf. LINE - LINE serigr.
LINE Serigrafiado - LINE siebdruck

V



opaline - opaline
opalin - opaco - opalglas

H



serigraf. STRIPE - STRIPE serigr.
STRIPE siebdruck - serigraf. STRIPE -
STRIPE serigr.

J



*altre finiture vetro disponibili a listino su richiesta - other glass finishes available on request
otros acabados de cristal disponibles bajo demanda - autres finitions de verre disponibles sur demande -
andere Listenglasuren auf Anfrage erhältlich*

PROFILI / PROFILES PERFILES / PROFILS / PROFILEN



cromo brillante - brilliant chrome
cromo brillante - chrome brillant
Chrom glänzend

QQ



legno teak - teak wood
madera alerce - larch bois - Lärche Holz

QT



minx

QM

ALTEZZA STANDARD STANDARD HEIGHT ALTURA ESTÁNDAR STANDARD HÖHE HAUTEUR STANDARD	h. 2090 mm
SPESSORE DEI VETRI GLASS THICKNESS ESPESOR DE VIDRIO GLASDICKE ÉPAISSEUR DU VERRE	6 mm
ALTEZZA DELLA MANIGLIA HANDLE HEIGHT ALTURA DE LA MANIJA HANDGRIFF HÖHE HAUTEUR DE LA POIGNÉE	/
TRATTAMENTO PROTECTIVE PROTECTIVE TREATMENT TRATAMIENTO PROTECTOR PROTECTIVE BEHANDLUNG TRAITEMENT PROTECTIVE	OPTION

**MODELLI / MODELS / MODELOS
MODÈLES / MODELLE**

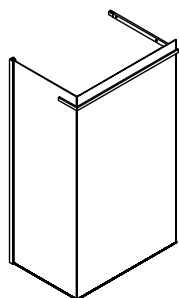

MATERIA SP2

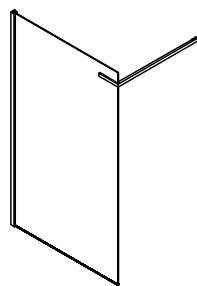

MATERIA SA1

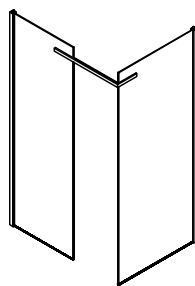

MATERIA SA2+SF1

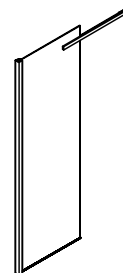

MATERIA SN1

**COMBINAZIONI / COMBINATIONS
COMBINACIONES / COMBINAISONS / KOMBINATIONEN**

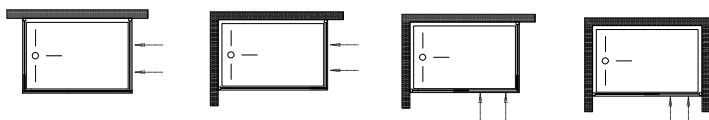

**PROFILI A MURO / WALL PROFILE / PERFIL DE PARED
PROFILÉS MURAU / WANDPROFIL**

Profilo a muro con finitura QQ
Wall profile with finishing QQ
Perfil de pared con acabado QQ
Profilés muraux avec finition QQ
Wandprofil mit finishing QQ

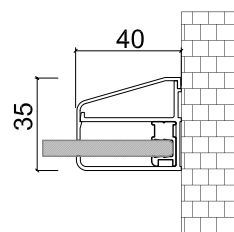

Profilo a muro con finitura QT - QM
Wall profile with finishing QT - QM
Perfil de pared con acabado QT - QM
Profilés muraux avec finition QT - QM
Wandprofil mit finishing QT - QM

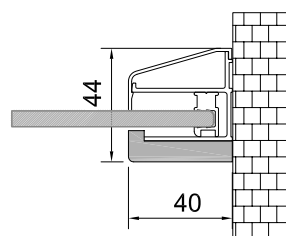



MATERIA SA2+SF1











SOLO
DOCCIA
EVO
SEPARÉ



I separè sono lastre di vetro che creano quinte scenografiche uniche
The booths are glass plates that create unique environments
Las cabinas son placas de vidrio que crean ambientes únicos
Les séparateurs sont des plaques de verre qui créent des environnements uniques
Die Kabinen sind Glasplatten, die einzigartige Umgebungen schaffen

solodoccia evo

I separè sono lastre di vetro che creano quinte scenografiche uniche
 The booths are glass plates that create unique environments
 Las cabinas son placas de vidrio que crean ambientes únicos
 Les séparateurs sont des plaques de verre qui créent des environnements uniques
 Die Kabinen sind Glasplatten, die einzigartige Umgebungen schaffen

SEPARÈ

VETRI TEMPERATI / TEMPERED GLASSES / CRISTAL TEMPLADO VERRÉS TREMPÉS / GETEMPERTE GLÄSER



PROFILI / PROFILES PERFILES / PROFILS / PROFILEN

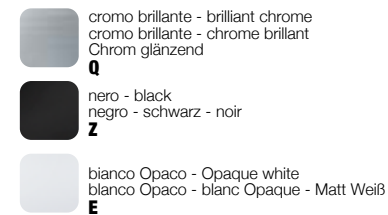

ALTEZZA STANDARD STANDARD HEIGHT ALTURA ESTÁNDAR STANDARD HÖHE HAUTEUR STANDARD	h. 2100 mm
SPESSORE DEI VETRI GLASS THICKNESS ESPESOR DE VIDRIO GLASDICKE ÉPAISSEUR DU VERRE	8 mm
ALTEZZA DELLA MANIGLIA HANDLE HEIGHT ALTURA DE LA MANIJA HANDGRIFF HÖHE HAUTEUR DE LA POIGNÉE	/
TRATTAMENTO PROTECTIVE PROTECTIVE TREATMENT TRATAMIENTO PROTECTOR PROTECTIVE BEHANDLUNG TRAITEMENT PROTECTIVE	INCLUDED

**MODELLI / MODELS / MODELOS
MODÈLES / MODELLE**

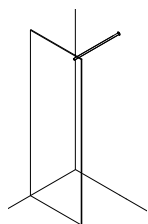

SOLODOCCIA SA0

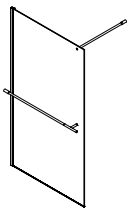

SOLODOCCIA SAP

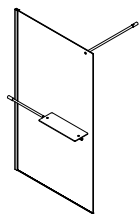

SOLODOCCIA SAM

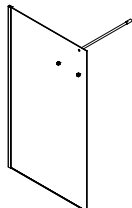

SOLODOCCIA SAA

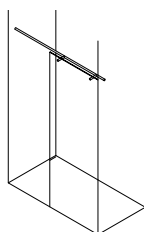

SOLODOCCIA SNO

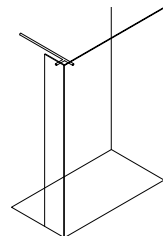

SOLODOCCIA SA2

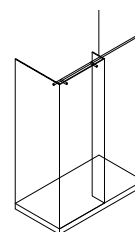

SOLODOCCIA SA4

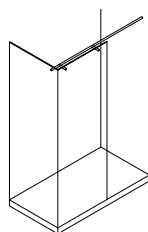

SOLODOCCIA SA3

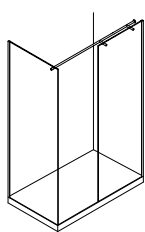

SOLODOCCIA SA1

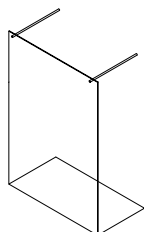

SOLODOCCIA SP0

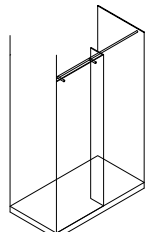

SOLODOCCIA SA5

**COMBINAZIONI / COMBINATIONS
COMBINACIONES / COMBINAISONS / KOMBINATIONEN**

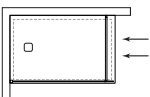
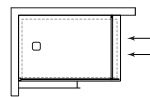
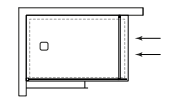
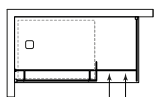
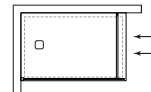
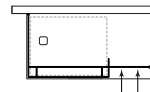
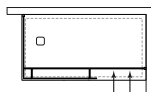
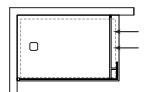
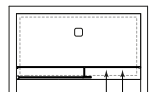
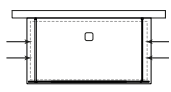

**PROFILI A MURO / WALL PROFILE / PERFIL DE PARED
PROFILÉS MURAUX / WANDPROFIL**

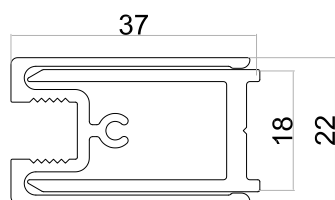

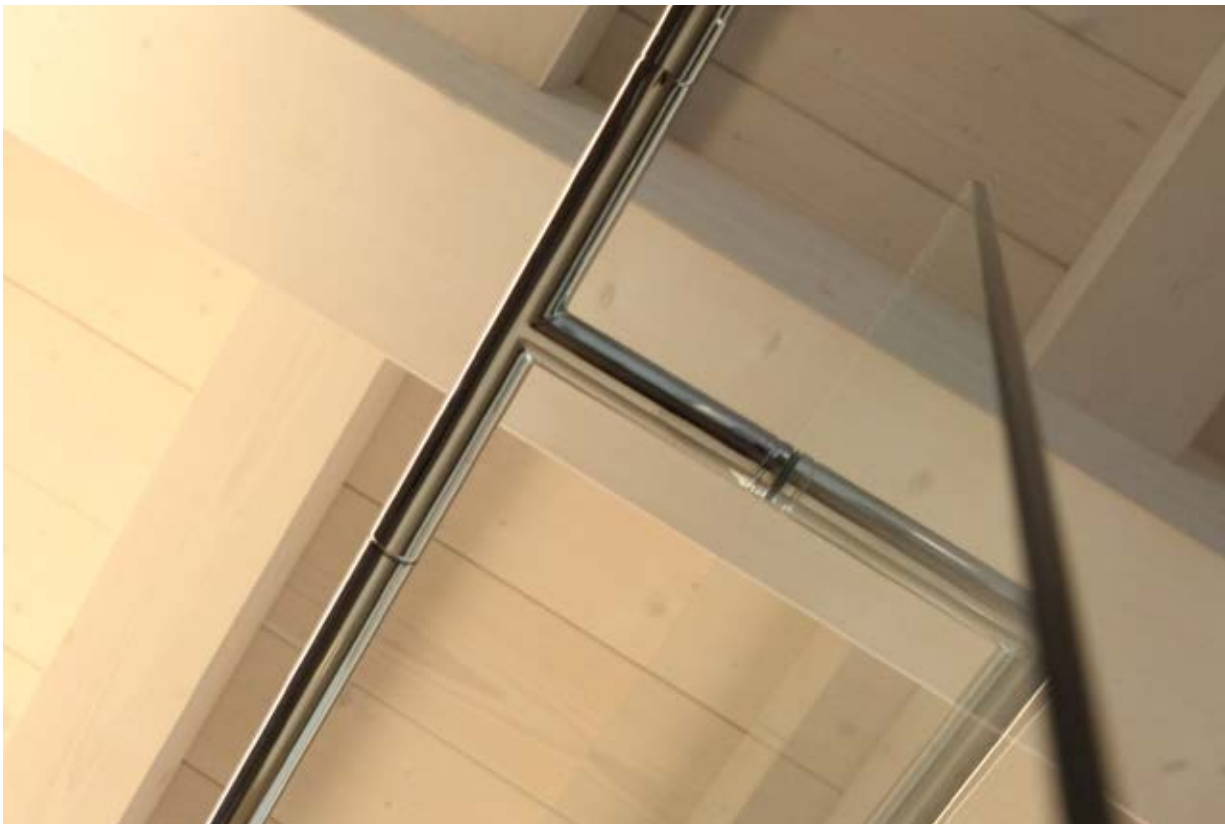
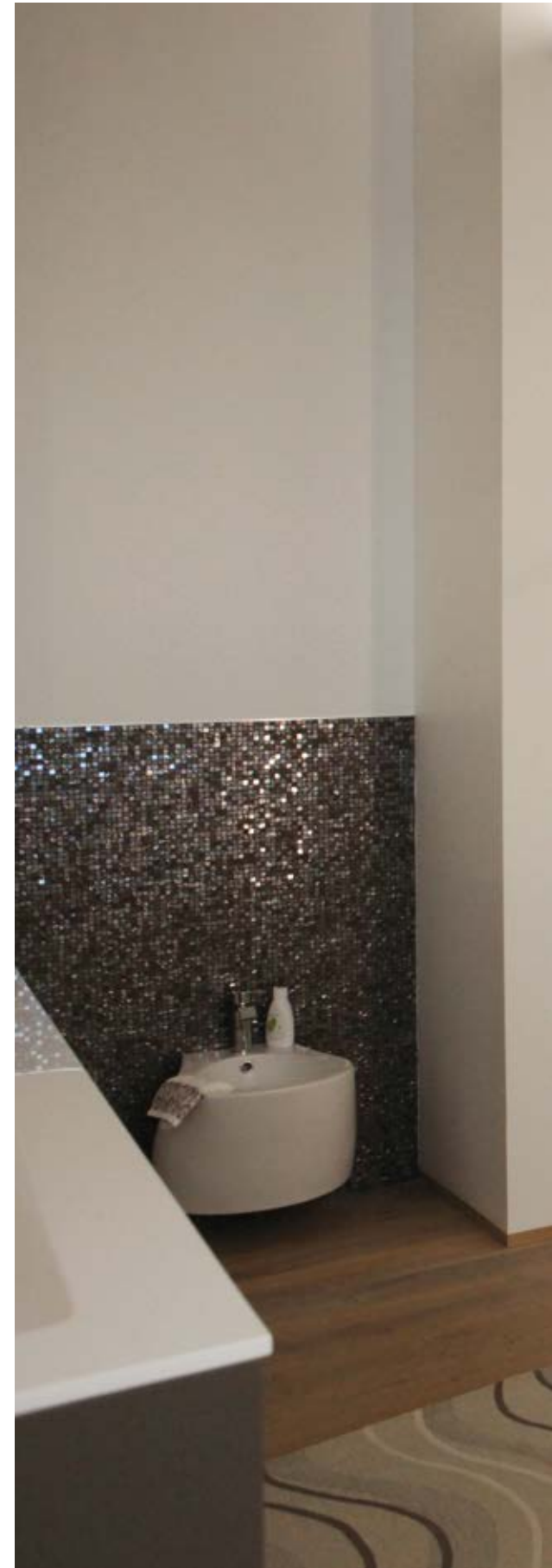

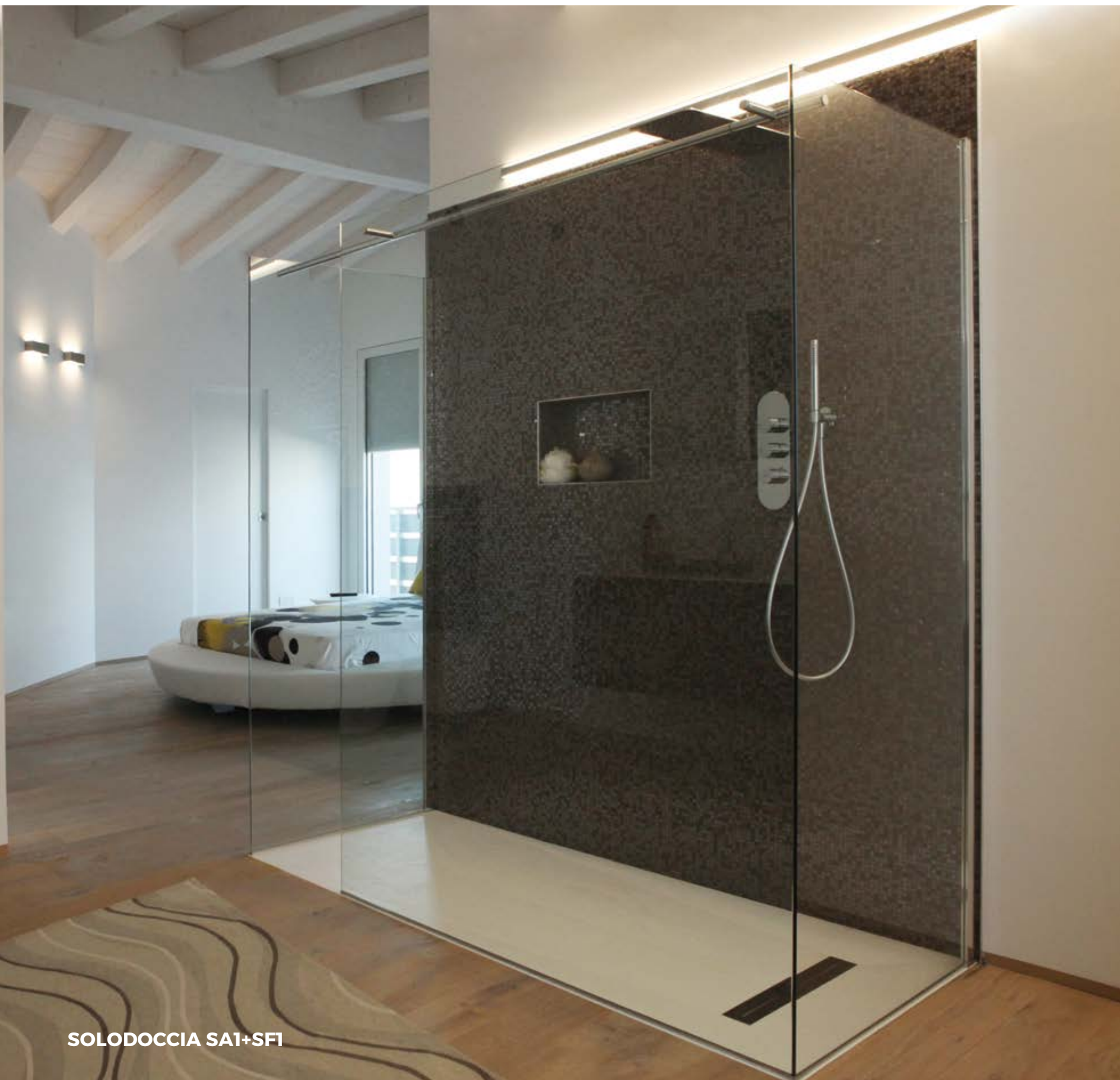

SOLODOCCIA SA1+SF1







MUR



Crea spazi di vetro con la doccia personalizzata interamente su misura.
Create glass spaces with the entirely custom-made shower.
Crea espacios de cristal con la ducha totalmente hecha a medida.
Créez des espaces vitrés avec la douche entièrement sur mesure.
Schaffen Sie Glasräume mit der komplett maßgeschneiderten Dusche.

mur

Crea spazi di vetro con la doccia personalizzata interamente su misura.
Create glass spaces with the entirely custom-made shower.
Crea espacios de cristal con la ducha totalmente hecha a medida.
Créez des espaces vitrés avec la douche entièrement sur mesure.
Schaffen Sie Glasräume mit der komplett maßgeschneiderten Dusche.

SEPARÈ

VETRI TEMPERATI / TEMPERED GLASSES / CRISTAL TEMPLADO VERRES TREMPÉS / GETEMPERTE GLÄSER



extrachiaro satinato - satin extra-clear
mate extra claro - satinierte extra klar

1Q



specchio - mirror
espejo - miroir -
Glasspiegel

D (no protective)



trasparente - transparent
transparent - transparente klarglas

F



vetro riflettente - reflective glass
vidrio reflejo - verre réfléchissant -
reflektierendes Glas

S



fumè satinato - satin fumè
gris fumè - mat fumée - satinierte Rauch

1A



oro satinato - satin gold
oro mate - mat gold - satinierte Gold

1H



extrachiaro mirage - mirage extra-clear
mirage extra claro - mirage extra-clair -
mirage extra klar

1M



specchio blu - blue mirror
espejo azul - bleu miroir - Blau-verspiegelt

1K (no protective)

PROFILI / PROFILES PERFILES / PROFILS / PROFILEN



argento lucido - silver shining
plata brillante - argent brillant -
Silber glänzend

R



nero - black
negro - schwarz - noir

Z

ALTEZZA STANDARD STANDARD HEIGHT ALTURA ESTÁNDAR STANDARD HÖHE HAUTEUR STANDARD	CUSTOM
SPESSORE DEI VETRI GLASS THICKNESS ESPESOR DE VIDRIO GLASDICKE ÉPAISSEUR DU VERRE	6/8/10 mm
ALTEZZA DELLA MANIGLIA HANDLE HEIGHT ALTURA DE LA MANIJA HANDGRIFF HÖHE HAUTEUR DE LA POIGNÉE	/
TRATTAMENTO PROTECTIVE PROTECTIVE TREATMENT TRATAMIENTO PROTECTOR PROTECTIVE BEHANDLUNG TRAITEMENT PROTECTIV	OPTION

**MODELLI / MODELS / MODELOS
MODÈLES / MODELLE**

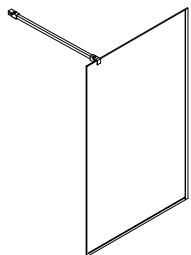

MUR

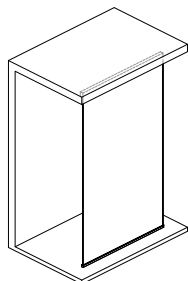

MUR

**PROFILI A MURO / WALL PROFILE / PERFIL DE PARED
PROFILÉS MURAUX / WANDPROFIL**

Profili a muro - Wall profile
Perfiles de pared - Profilés muraux -
Wandprofil

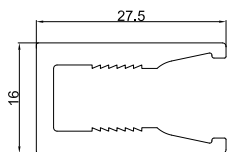

Profilo a pavimento - Floor profile
Perfil de suelo - Profil de plancher
- Bodenprofil

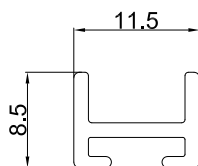











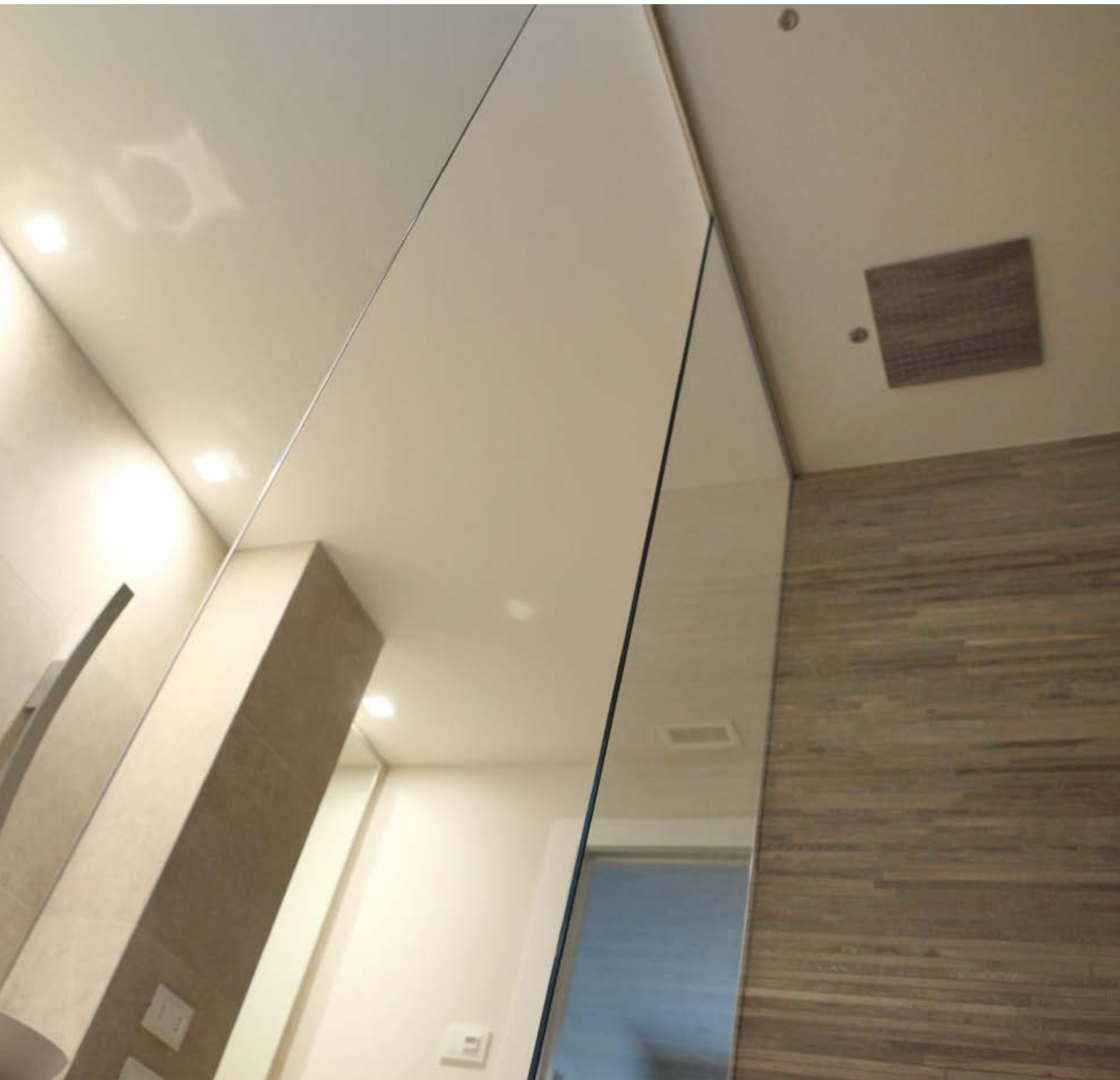











LETTER



I separè sono lastre di vetro che creano quinte scenografiche uniche
The booths are glass plates that create unique environments
Las cabinas son placas de vidrio que crean ambientes únicos
Les séparateurs sont des plaques de verre qui créent des environnements uniques
Die Kabinen sind Glasplatten, die einzigartige Umgebungen schaffen

eter

I separè sono lastre di vetro che creano quinte scenografiche uniche

The booths are glass plates that create unique environments

Las cabinas son placas de vidrio que crean ambientes únicos

Les séparateurs sont des plaques de verre qui créent des environnements uniques

Die Kabinen sind Glasplatten, die einzigartige Umgebungen schaffen

SEPARÈ

VETRI TEMPERATI / TEMPERED GLASSES / CRISTAL TEMPLADO VERRES TREMPÉS / GETEMPERTE GLÄSER

 specchio - mirror espejo - miroir - Glasspiegel D (no protective)	 serigraf. STRIPE - STRIPE serigr. STRIPE siebdruck - serigraf. STRIPE - STRIPE serigr. J	 extrachiaro mirage - mirage extra-clear mirage extra claro - mirage extra-clair - mirage extra klar 1N	 serigraf. LINE - LINE serigr. LINE Serigrafado - LINE siebdruck V
 trasparente - transparent transparent - transparente klarglas F	 fumè satinato - satin fumè gris fumè - mat fumée - satinierte Rauch 1A	 oro satinato - satin gold gris fumè - mat gold - satinierte Gold 1H	 vetro riflettente - reflective glass vidrio reflejo - verre réfléchissant - reflektierendes Glas S
 extrachiaro satinato - satin extra-clear mate extra claro - satinierte extra klar 1Q	 specchio blu - blue mirror espejo azul - bleu miroir - blauer Spiegel 1K (no protective)	 MOSAIC CROM C	 extrachiaro mirage - mirage extra-clear mirage extra claro - mirage extra-clair - mirage extra klar 1M
 fumè - rauchglas humo - fumado N	 Bronzo satinato - Bronze matt Bronze satinado - Bronze Satiné - Bronze Satin 1J	 serigraf. MOSAIC WHITE Serigrafado MOSAIC WHITE W	 opaline - opaline opalino - opalin - opalglas O
 extrachiaro fabric or - Fabric extra-clear or Fabric extra claro or - Fabric extra-clair or Fabric extra klar or 1T	 extrachiaro fabric vr - Fabric extra-clear vr Fabric extra claro vr - Fabric extra-clair vr Fabric extra klar vr 1S		

PROFILI / PROFILES PERFILES / PROFILS / PROFILEN

 nero - black negro - schwarz - noir Z	 bronzo lucido - polished bronze bronce brillante - bronze brillantglänzende Bronze B	 rame spazzolato - brushed copper cobre cepillado - cuivre brossé - gebürstete Kupfer 9
 argento lucido - silver shining plata brillante - argent brillant - Silber glänzend R	 bronzo spazzolato - brushed bronze - bronze cepillado bronze brossé - gebürstete Bronze 8	 oro rosè satinato - satin-finished rosé gold - oro rosa mate - or rose mat - satinierte Rose'-Gold 4
 finitura acciaio spazzolato - brushed steel finish - acabado acero cepillado inox brossé - Ausführung gebürstet 3	 bronzo satinato - satin bronze bronce mate - bronze mat satinierte Bronze W	 oro rosè lucido - polished rosé gold - oro rosa brillante - or rose brillant - glänzende Rose'-Gold D
 grafite satinato - satin graphite graphite mate - graphite mat satinierte Graphite C	 oro lucido - polished gold oro brillante - or brillant - gold glänzend I	 oro spazzolato - brushed gold oro cepillado - or brossé - gebürstete Gold 7

ALTEZZA STANDARD STANDARD HEIGHT ALTURA ESTÁNDAR STANDARD HÖHE HAUTEUR STANDARD	h. 2000 mm
SPESSORE DEI VETRI GLASS THICKNESS ESPESOR DE VIDRIO GLASDICKE ÉPAISSEUR DU VERRE	8 mm
ALTEZZA DELLA MANIGLIA HANDLE HEIGHT ALTURA DE LA MANIJA HANDGRIFF HÖHE HAUTEUR DE LA POIGNÉE	/
TRATTAMENTO PROTECTIVE PROTECTIVE TREATMENT TRATAMIENTO PROTECTOR PROTECTIVE BEHANDLUNG TRAITEMENT PROTECTIVE	OPTION

**MODELLI / MODELS / MODELOS
MODÈLES / MODELLE**

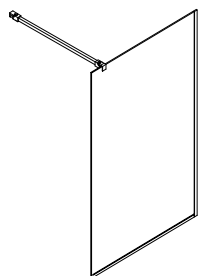

ETER SA0

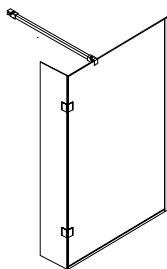

ETER SAC

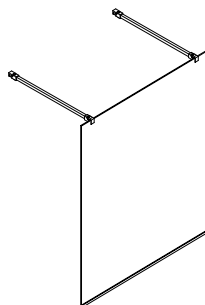

ETER SPO

**COMBINAZIONI / COMBINATIONS
COMBINACIONES / COMBINAISONS / KOMBINATIONEN**

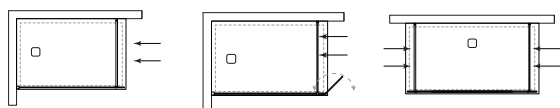

**PROFILI A MURO / WALL PROFILE / PERFIL DE PARED
PROFILÉS MURAUX / WANDPROFIL**

Profili a muro - Wall profile
Perfiles de pared - Profilés muraux - Wandprofil

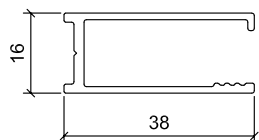



ETER SAO









ETER SAO





ETER SAO





VITROS



I separè sono lastre di vetro che creano quinte scenografiche uniche
The booths are glass plates that create unique environments
Las cabinas son placas de vidrio que crean ambientes únicos
Les séparateurs sont des plaques de verre qui créent des environnements uniques
Die Kabinen sind Glasplatten, die einzigartige Umgebungen schaffen

vitros

I separè sono lastre di vetro che creano quinte scenografiche uniche

The booths are glass plates that create unique environments

Las cabinas son placas de vidrio que crean ambientes únicos

Les séparateurs sont des plaques de verre qui créent des environnements uniques

Die Kabinen sind Glasplatten, die einzigartige Umgebungen schaffen

SEPARÈ

VETRI TEMPERATI / TEMPERED GLASSES / CRISTAL TEMPLADO VERRES TREMPÉS / GETEMPERTE GLÄSER



trasparente - transparent
transparent - transparente klarglas

F



MOSAIC CROM

C



fumè - rauchglas
humo - fumado

N



serigraf. MOSAIC WHITE
Serigrafado MOSAIC WHITE

W



serigraf. STRIPE - STRIPE serigr.
STRIPE siebdruk - serigraf. STRIPE -
STRIPE serigr.

J



serigraf. LINE - LINE serigr.
LINE Serigrafado - LINE siebdruk

V

PROFILI / PROFILES PERFILES / PROFILS / PROFILEN



nero - black
negro - schwarz - noir

Z



argento satinato - silver mat
plata satinado - argent satiné -
Silber matt

K



argento lucido - silver shining
plata brillante - argent brillant -
Silber glänzend

R



grafite satinato - satin graphite
graphite mate - graphite mat
satinierte Graphite

NEW 2024

C



bianco Opaco - Opaque white
blanco Opaco - blanc Opaque - Matt Weiß

E

ALTEZZA STANDARD STANDARD HEIGHT ALTURA ESTÁNDAR STANDARD HÖHE HAUTEUR STANDARD	h. 1950 mm
SPESSORE DEI VETRI GLASS THICKNESS ESPESOR DE VIDRIO GLASDICKE ÉPAISSEUR DU VERRE	6 mm
ALTEZZA DELLA MANIGLIA HANDLE HEIGHT ALTURA DE LA MANIJA HANDGRIFF HÖHE HAUTEUR DE LA POIGNÉE	/
TRATTAMENTO PROTECTIVE PROTECTIVE TREATMENT TRATAMIENTO PROTECTOR PROTECTIVE BEHANDLUNG TRAITEMENT PROTECTIVE	OPTION

MODELLI / MODELS / MODELOS
 MODÈLES / MODELLE

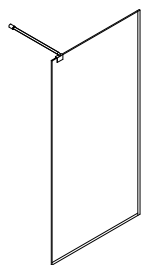

VITROS SA0

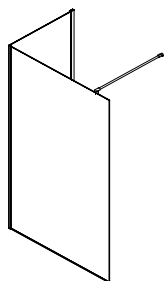

VITROS SA0+SP2

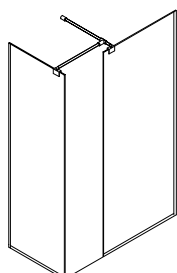

VITROS SA0 + SF1

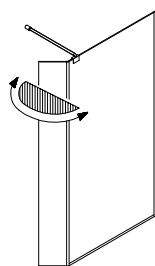

VITROS SAX

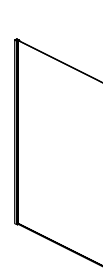

VITROS SAZ

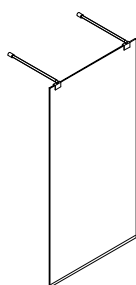

VITROS SP0

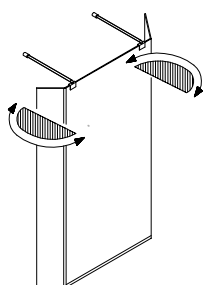

VITROS SPX

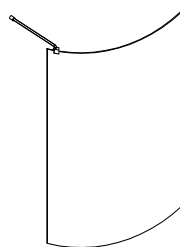

VITROS ROUND

COMBINAZIONI / COMBINATIONS
 COMBINACIONES / COMBINAISONS / KOMBINATIONEN

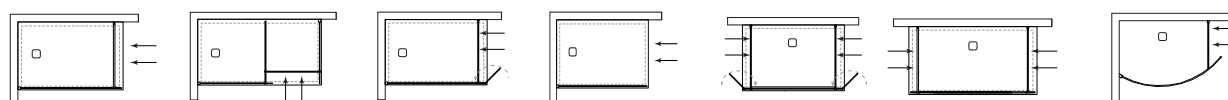

PROFILI A MURO / WALL PROFILE / PERFIL DE PARED
 PROFILÉS MURAUX / WANDPROFIL

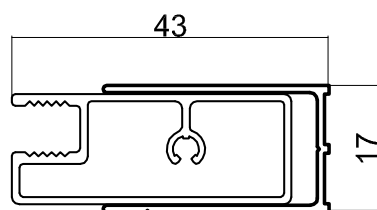

VITROS SAO











MARIPOSA



I separè sono lastre di vetro che creano quinte scenografiche uniche
The booths are glass plates that create unique environments
Las cabinas son placas de vidrio que crean ambientes únicos
Les séparateurs sont des plaques de verre qui créent des environnements uniques
Die Kabinen sind Glasplatten, die einzigartige Umgebungen schaffen

mariposa

SEPARÈ

I separè sono lastre di vetro che creano quinte scenografiche uniche
The booths are glass plates that create unique environments
Las cabinas son placas de vidrio que crean ambientes únicos
Les séparateurs sont des plaques de verre qui créent des environnements uniques
Die Kabinen sind Glasplatten, die einzigartige Umgebungen schaffen

VETRI TEMPERATI / TEMPERED GLASSES / CRISTAL TEMPLADO VERRES TREMPÉS / GETEMPERTE GLÄSER



trasparente - transparent
transparent - transparente klarglas

F



MOSAIC CROM

C



fumè - rauchglas
humo - fumado

N



serigraf. MOSAIC WHITE
Serigrafado MOSAIC WHITE

W



serigraf. STRIPE - STRIPE serigr.
STRIPE siebdruk - serigraf. STRIPE -
STRIPE serigr.

J



serigraf. LINE - LINE serigr.
LINE Serigrafado - LINE siebdruk

V

PROFILI / PROFILES PERFILES / PROFILS / PROFILEN



nero - black
negro - schwarz - noir

Z



argento satinato - silver mat
plata satinado - argent satiné -
Silber matt

K



argento lucido - silver shining
plata brillante - argent brillant -
Silber glänzend

R

ALTEZZA STANDARD STANDARD HEIGHT ALTURA ESTÁNDAR STANDARD HÖHE HAUTEUR STANDARD	h. 1950 mm
SPESSORE DEI VETRI GLASS THICKNESS ESPESOR DE VIDRIO GLASDICKE ÉPAISSEUR DU VERRE	6 mm
ALTEZZA DELLA MANIGLIA HANDLE HEIGHT ALTURA DE LA MANIJA HANDGRIFF HÖHE HAUTEUR DE LA POIGNÉE	/
TRATTAMENTO PROTECTIVE PROTECTIVE TREATMENT TRATAMIENTO PROTECTOR PROTECTIVE BEHANDLUNG TRAITEMENT PROTECTIVE	OPTION

MODELLI / MODELS / MODELOS
MODÈLES / MODELLE

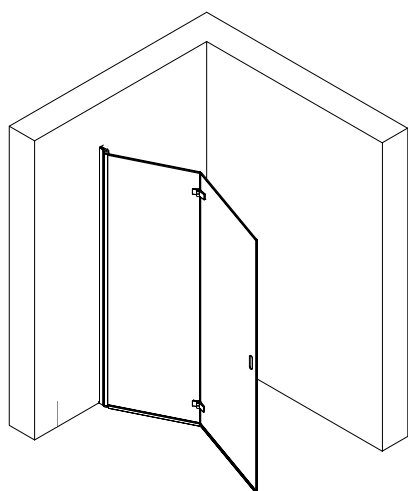

COMBINAZIONI / COMBINATIONS
COMBINACIONES / COMBINAISONS / KOMBINATIONEN

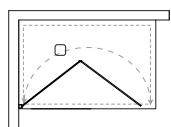





LUX





I separè sono lastre di vetro che creano quinte scenografiche uniche
The booths are glass plates that create unique environments
Las cabinas son placas de vidrio que crean ambientes únicos
Les séparateurs sont des plaques de verre qui créent des environnements uniques
Die Kabinen sind Glasplatten, die einzigartige Umgebungen schaffen

lux

I separè sono lastre di vetro che creano quinte scenografiche uniche
The booths are glass plates that create unique environments
Las cabinas son placas de vidrio que crean ambientes únicos
Les séparateurs sont des plaques de verre qui créent des environnements uniques
Die Kabinen sind Glasplatten, die einzigartige Umgebungen schaffen

SEPARÈ

VETRI TEMPERATI / TEMPERED GLASSES / CRISTAL TEMPLADO VERRES TREMPÉS / GETEMPERTE GLÄSER



trasparente - transparent
transparent - transparente klarglas

F



specchio - mirror
espejo - miroir - Glasspie-
gel

D (no protective)



extra chiaro - extra clear
extraclair - extraclaro - extra claro

Q



*altre finiture vetro disponibili a listino su richiesta
other glass finishes available on request
otros acabados de cristal disponibles bajo demanda
autres finitions de verre disponibles sur demande
Andere Glasausführungen auf Anfrage möglich*

PROFILI / PROFILES PERFILES / PROFILS / PROFILEN



acciaio lucido - Shining steel
acero brillante - acier brillant - Stahl glänzend



Acciaio satinato - Brushed steel - acero cepillado
Acier brossé - Gebürstetem Stahl

ALTEZZA STANDARD STANDARD HEIGHT ALTURA ESTÁNDAR STANDARD HÖHE HAUTEUR STANDARD	h. 2000 mm
SPESSORE DEI VETRI GLASS THICKNESS ESPESOR DE VIDRIO GLASDICKE ÉPAISSEUR DU VERRE	8 mm
ALTEZZA DELLA MANIGLIA HANDLE HEIGHT ALTURA DE LA MANIJA HANDGRIFF HÖHE HAUTEUR DE LA POIGNÉE	/
TRATTAMENTO PROTECTIVE PROTECTIVE TREATMENT TRATAMIENTO PROTECTOR PROTECTIVE BEHANDLUNG TRAITEMENT PROTECTIVE	INCLUDED

MODELLI / MODELS / MODELOS MODÈLES / MODELLE

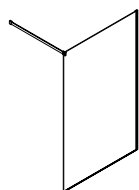

LUX SA0







DETAIL



La doccia tailor made dal design minimale
The tailor-made shower with minimal design
La ducha tailor hecho de diseño minimalista
La douche tailor réalisée avec un design minimaliste
Die minimale Tailor Made Dusche

detail

La doccia tailor made dal design minimale
The tailor-made shower with minimal design
La ducha tailor hecho de diseño minimalista
La douche tailor réalisée avec un design minimaliste
Die minimale Tailor Made Dusche

PIVOT | SEPARÈ

VETRI TEMPERATI / TEMPERED GLASSES / CRISTAL TEMPLADO VERRES TREMPÉS / GETEMPERTE GLÄSER



trasparente - transparent
transparent - transparente
klarglas

F



extrachiaro satinato - satin extra-clear
mate extra claro - satinierte extra klar

1Q



fumè satinato - satin fumè
gris fumè - mat fumée - satinierte
Rauch

1A



bronzo - bronze
bronce - bronce

1Z



*altre finiture vetro disponibili a listino su richiesta
other glass finishes available on request
otros acabados de cristal disponibles bajo demanda
autres finitions de verre disponibles sur demande
Andere Glasausführungen auf Anfrage möglich*

PROFILI / PROFILES PERFILES / PROFILS / PROFILEN



cromo brillante - brilliant chrome
cromo brillante - chrome brillant
Chrom glänzend

Q



nero - black
negro - schwarz - noir

Z



finitura acciaio spazzolato - brushed
steel finish - acabado acero cepillado
inox brossé - Ausführung gebürs

3



bronzo satinato - satin bronze
bronce mate - bronce mat satinierte Bronze

W



oro spazzolato - brushed gold
oro cepillado - or brossé - gebürstete Gold

7



*altre finiture profilo disponibili a listino su richiesta
other profile finishes available on request
otros acabados de perfil disponibles bajo demanda
autres finitions de profils disponibles sur demande
Andere Profilausführungen auf Anfrage möglich*

ALTEZZA STANDARD STANDARD HEIGHT ALTURA ESTÁNDAR STANDARD HÖHE HAUTEUR STANDARD	h. 2000 mm
SPESSORE DEI VETRI GLASS THICKNESS ESPEJOR DE VIDRIO GLASDICKE ÉPAISSEUR DU VERRE	8 mm
ALTEZZA DELLA MANIGLIA HANDLE HEIGHT ALTURA DE LA MANIJA HANDGRIFF HÖHE HAUTEUR DE LA POIGNÉE	/
TRATTAMENTO PROTECTIVE PROTECTIVE TREATMENT TRATAMIENTO PROTECTOR PROTECTIVE BEHANDLUNG TRAITEMENT PROTECTIVE	OPTION

**MODELLI / MODELS / MODELOS
MODÈLES / MODELLE**

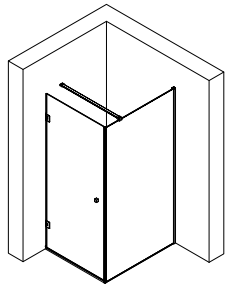

DETAIL A 1/2 + F00

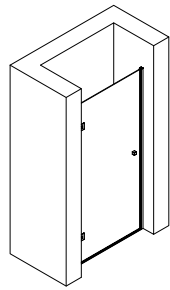

DETAIL PB0

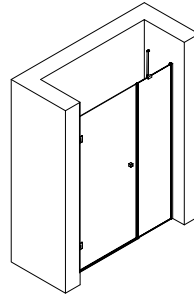

DETAIL PBF

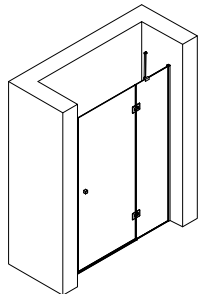

DETAIL B1F

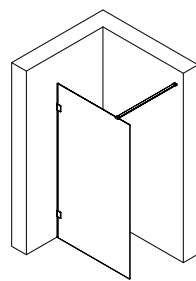

DETAIL SA0

**COMBINAZIONI / COMBINATIONS
COMBINACIONES / COMBINAISONS / KOMBINATIONEN**

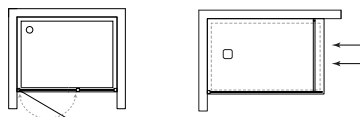
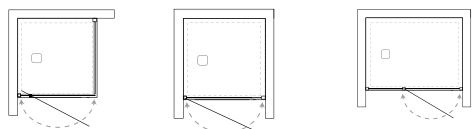











SO FIST



So.llevabile, F.ilo I.nterno, S.pingi T.ira
Liftable, inner thread, push and pull
Elevable, rosca interior, empujar y tirar
Relevable, filetage intérieur, pousser et tirer
Anhebbar, Innengewinde, schieben und ziehen

sofist

So.llevabile, F.ilo I.terno, S.pingi T.ira
Liftable, inner thread, push and pull
Elevable, rosca interior, empujar y tirar
Relevable, filetage intérieur, pousser et tirer
Anhebbar, Innengewinde, schieben und ziehen

PIVOT

VETRI TEMPERATI / TEMPERED GLASSES / CRISTAL TEMPLADO VERRES TREMPÉS / GETEMPERTE GLÄSER



trasparente - transparent
transparent - transparente klarglas

F



extra chiaro - extra clear
extraclair - extraclaro - extra claro

Q



fumè - rauchglas
humo - fumado

N



serigraf. LINE - LINE serigr.
LINE Serigrafiado - LINE siebdruck

V



serigraf. STRIPE - STRIPE serigr.
STRIPE siebdruck - serigraf. STRIPE - STRIPE serigr.

J

PROFILI / PROFILES PERFILES / PROFILS / PROFILEN



Cromo brillante - brilliant chrome
Cromo brillante - chrome brillant
Chrom glänzend

Q



alluminio Spazzolato - brushed
Aluminum - aluminio Cepillado
aluminium Brossé - gebürstetes

F

ALTEZZA STANDARD STANDARD HEIGHT ALTURA ESTÁNDAR STANDARD HÖHE HAUTEUR STANDARD	h. 2040 mm
SPESSORE DEI VETRI GLASS THICKNESS ESPESOR DE VIDRIO GLASDICKE ÉPAISSEUR DU VERRE	8 mm
ALTEZZA DELLA MANIGLIA HANDLE HEIGHT ALTURA DE LA MANIJA HANDGRIFF HÖHE HAUTEUR DE LA POIGNÉE	580 mm
TRATTAMENTO PROTECTIVE PROTECTIVE TREATMENT TRATAMIENTO PROTECTOR PROTECTIVE BEHANDLUNG TRAITEMENT PROTECTIVE	INCLUDED

**MODELLI / MODELS / MODELOS
MODÈLES / MODELLE**

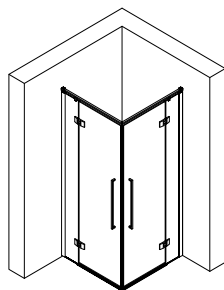

SOFIST A 1/2

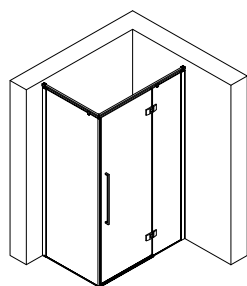

SOFIST B1F + F00

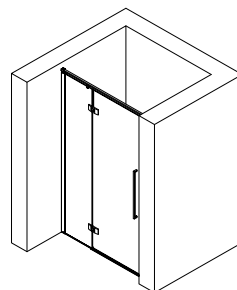

SOFIST B1F

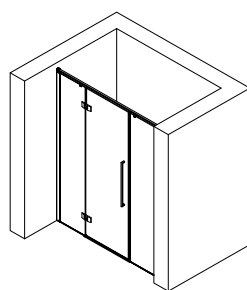

SOFIST B2F

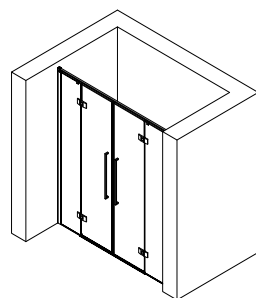

SOFIST SAL

**COMBINAZIONI / COMBINATIONS
COMBINACIONES / COMBINAISONS / KOMBINATIONEN**

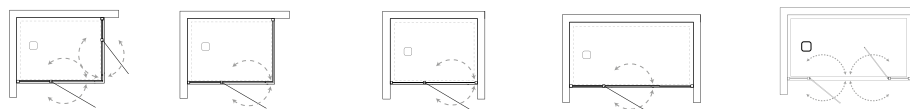

**PROFILI A MURO / WALL PROFILE / PERFIL DE PARED
PROFILÉS MURAUX / WANDPROFIL**

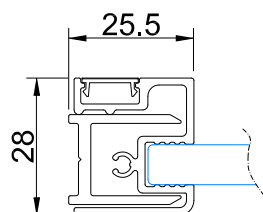

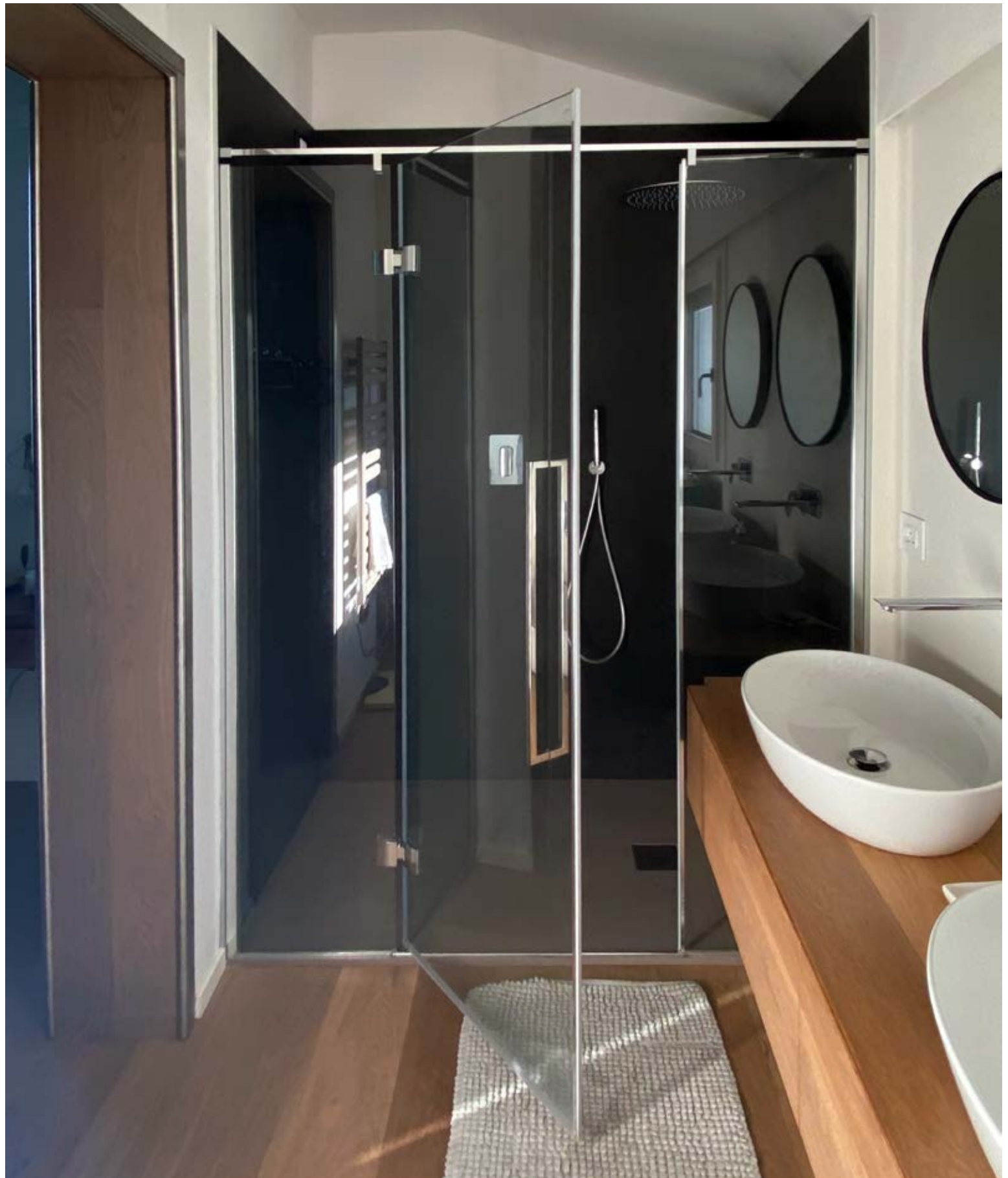









SOFIST B1F+F00





STILL LIBERO



La doccia battente essenziale e concreta
The essential and concrete swing shower
La ducha abatible esencial y concreta
La douche battante incontournable et en béton
Die unverzichtbare Schaukeldusche aus Beton

stile libero

La doccia battente essenziale e concreta
The essential and concrete swing shower
El columpio esencial y concreto de ducha
La douche balançoire essentielle et concrète
Die essentielle und konkrete Schaukeldusche

PIVOT

VETRI TEMPERATI / TEMPERED GLASSES / CRISTAL TEMPLADO VERRES TREMPÉS / GETEMPERTE GLÄSER



trasparente - transparent
transparent - transparente klarglas

F



extra chiaro - extra clear
extraclair - extraclaro - extra claro

Q



fumè - rauchglas
humo - fumado

N



serigraf. LINE - LINE serigr.
LINE Serigrafiado - LINE siebdruk

V



serigraf. STRIPE - STRIPE serigr.
STRIPE siebdruk - serigraf. STRIPE -
STRIPE serigr.

J



opaline - opaline
opalino - opalin - opalglas

O

PROFILI / PROFILES PERFILES / PROFILS / PROFILEN



argento lucido - silver shining
plata brillante - argent brillant -
Silber glänzend

R

ALTEZZA STANDARD STANDARD HEIGHT ALTURA ESTÁNDAR STANDARD HÖHE HAUTEUR STANDARD	h. 2000 mm
SPESSORE DEI VETRI GLASS THICKNESS ESPESOR DE VIDRIO GLASDICKE ÉPAISSEUR DU VERRE	8 mm
ALTEZZA DELLA MANIGLIA HANDLE HEIGHT ALTURA DE LA MANIJA HANDGRIFF HÖHE HAUTEUR DE LA POIGNÉE	160 mm
TRATTAMENTO PROTECTIVE PROTECTIVE TREATMENT TRATAMIENTO PROTECTOR PROTECTIVE BEHANDLUNG TRAITEMENT PROTECTIVE	INCLUDED

**MODELLI / MODELS / MODELOS
MODÈLES / MODELLE**

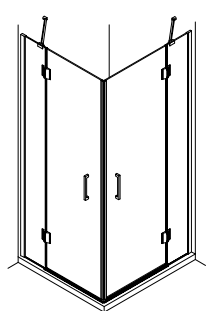

STILE LIBERO A 1/2

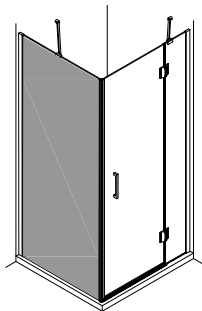

STILE LIBERO F00 / FAS

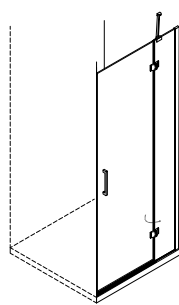

STILE LIBERO B1F

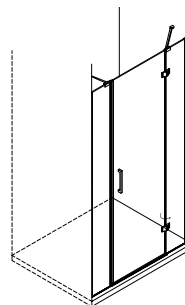

STILE LIBERO B2F

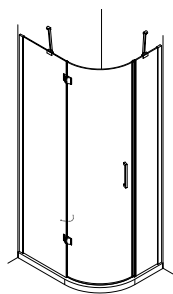

STILE LIBERO S1B

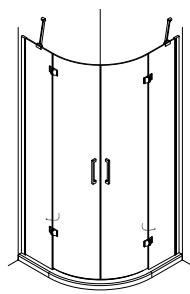

STILE LIBERO R2B

**COMBINAZIONI / COMBINATIONS
COMBINACIONES / COMBINAISONS / KOMBINATIONEN**

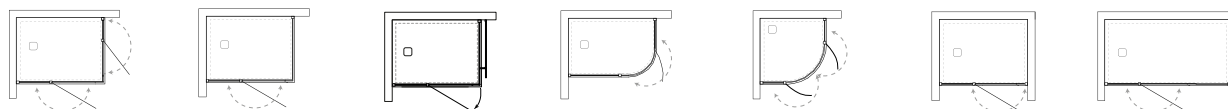

**PROFILI A MURO / WALL PROFILE / PERFIL DE PARED
PROFILÉS MURAUX / WANDPROFIL**

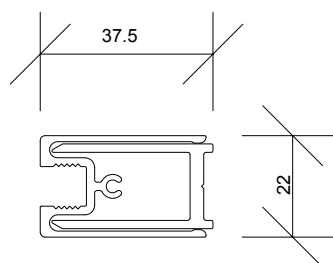





STILE LIBERO S1B

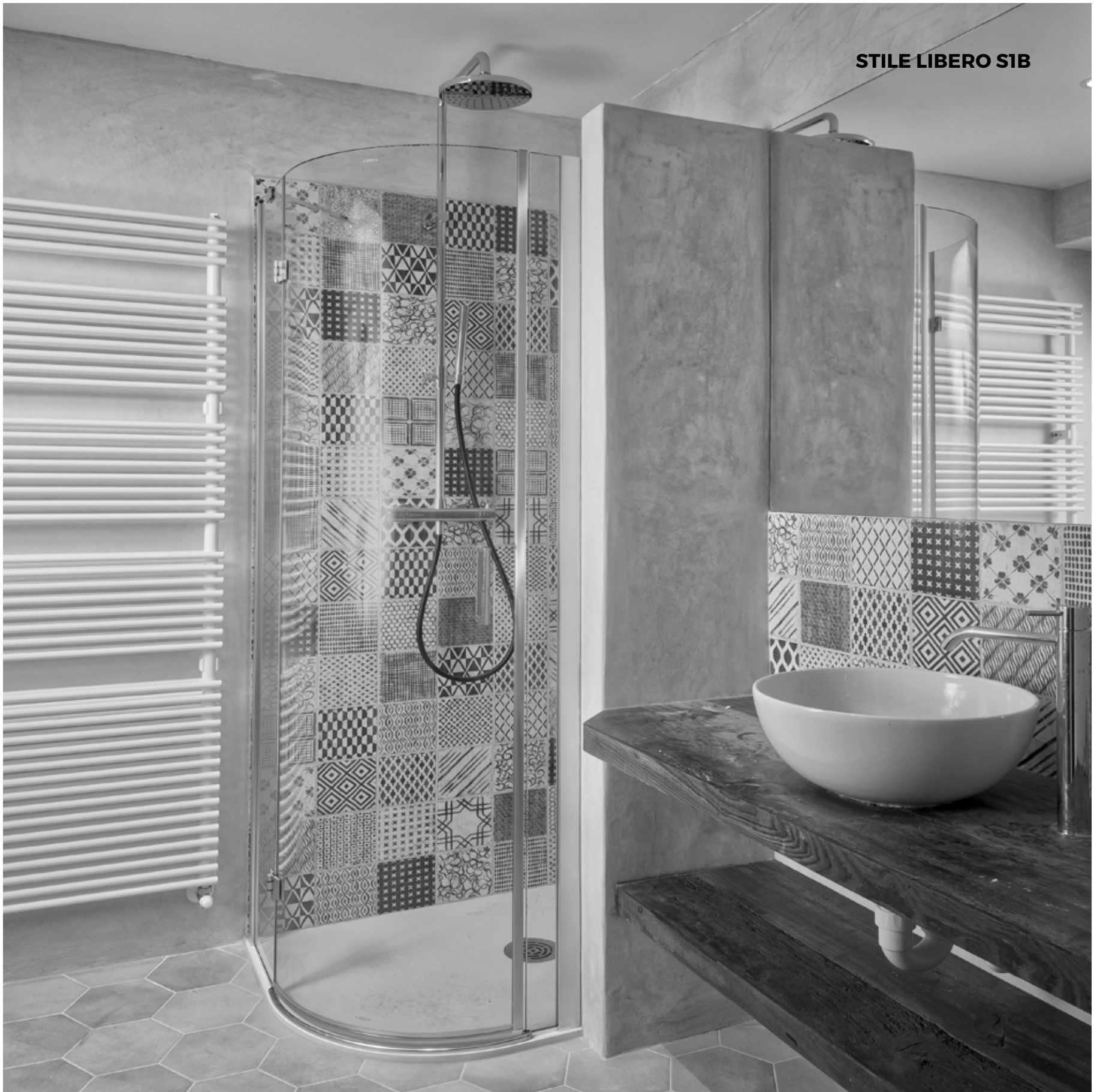





PRISMA
1.0



Equilibrio Geometrico
Geometric balance
Balance géométrico
Balance géométrique
Geometrisches Gleichgewicht

prisma 1.0

Equilibrio Geometrico
Geometric balance
Balance geométrico
Balance géométrique
Geometrisches Gleichgewicht

PIVOT

VETRI TEMPERATI / TEMPERED GLASSES / CRISTAL TEMPLADO
VERRES TREMPÉS / GETEMPERTE GLÄSER



specchio - mirror
espejo - miroir -
Glasspiegel

D (no protective)



trasparente - transparent
transparent - transparente
klarglas

F



extra chiaro - extra clear
extraclair - extraclaro - extra claro

Q



bronzo - bronze
bronce - bronce - bronze

1Z



extrachiaro flute - flute extra-clear
flute extra claro -flute extra-clair - flute
extra klar

NEW 2024

1X (8 mm)



extrachiaro satinato - satin extra-clear
mate extra claro - satinierter extra klar

1Q



fumè satinato - satin fumè
gris fumè - mat fumée - satinierter
Rauch

1A



extrachiaro fabric or - Fabric extra-clear or
Fabric extra claro or - Fabric extra-clair or
Fabric extra klar or

1T



extrachiaro fabric vr - Fabric extra-clear vr
Fabric extra claro vr - Fabric extra-clair vr
Fabric extra klar vr

1S

PROFILI / PROFILES

PERFILES / PROFILS / PROFILEN



cromo brillante - brilliant chrome
cromo brillante - chrome brillant
Chrom glänzend

Q



nero - black
negro - schwarz - noir

Z



alluminio spazzolato - brushed Aluminum -
aluminio Cepillado
aluminium Brossé - gebürstetes

F



finitura acciaio spazzolato - brushed steel
finish - acabado acero cepillado
inox brossé - Ausführung gebürs

3



grafite satinato - satin graphite
graphite mate - graphite mat
satinierter Graphite

NEW 2024

rame spazzolato - brushed copper
cobre cepillado - cuivre brossé - gebür-
stete Kupfer

9



oro rosé satinato - satin-finished rosé gold
- oro rosa mate - or rose mat - satinierter
Rose-Gold

4



bronzo lucido - polished bronze
bronce brillante - bronce brillantglänzende
Bronze

B



bronzo spazzolato - brushed bronze -
bronce cepillado
bronce brossé - gebürstete Bronze

8



bronzo satinato - satin bronze
bronce mate - bronce mat satinierter Bronze

W



oro lucido - polished gold
oro brillante - or brilliant - gold glänzend

I



oro spazzolato - brushed gold
oro cepillado - or brossé - gebürstete Gold

7



oro rosé lucido - polished rosé gold
- oro rosa brillante -or rose brillant -
glänzende Rose-Gold

D



bianco Opaco - Opaque white
blanco Opaco - blanc Opaque - Matt Weiß

E

ALTEZZA STANDARD STANDARD HEIGHT ALTURA ESTÁNDAR STANDARD HÖHE HAUTEUR STANDARD	h. 2000 mm
SPESSORE DEI VETRI GLASS THICKNESS ESPESOR DE VIDRIO GLASDICKE ÉPAISSEUR DU VERRE	8 mm
ALTEZZA DELLA MANIGLIA HANDLE HEIGHT ALTURA DE LA MANIJA HANDGRIFF HÖHE HAUTEUR DE LA POIGNÉE	320 mm
TRATTAMENTO PROTECTIVE PROTECTIVE TREATMENT TRATAMIENTO PROTECTOR PROTECTIVE BEHANDLUNG TRAITEMENT PROTECTIVE	OPTION

**MODELLI / MODELS / MODELOS
MODÈLES / MODELLE**

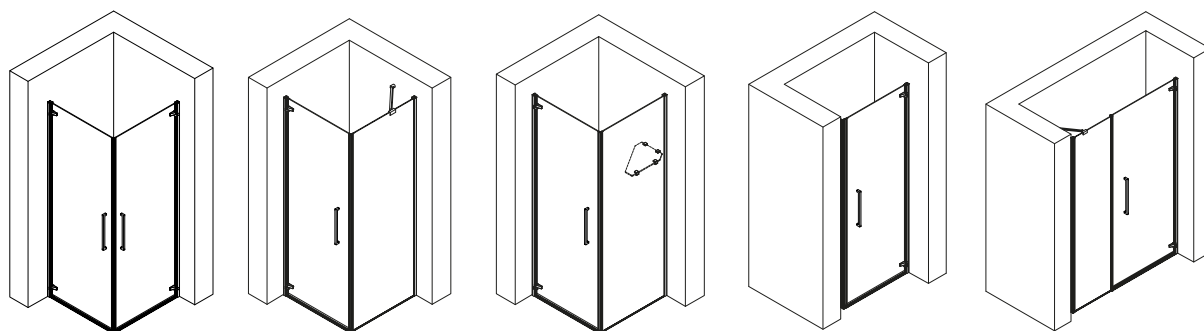

PRISMA 1.0 A 1/2

PRISMA 1.0 F00

PRISMA 1.0 FMO

PRISMA 1.0 PBO

PRISMA 1.0 PBF

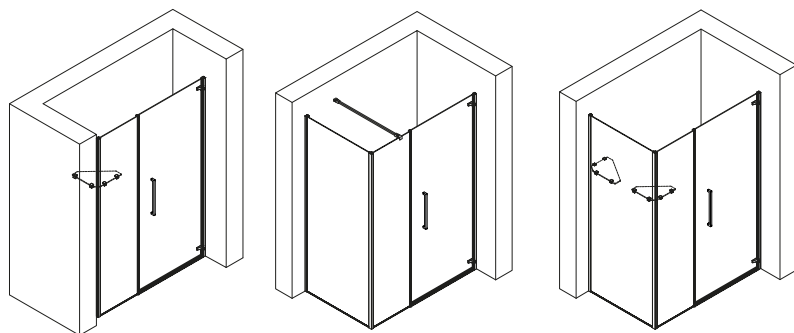

PRISMA 1.0 PBM

PRISMA 1.0 F1F

PRISMA 1.0 FMF

**COMBINAZIONI / COMBINATIONS
COMBINACIONES / COMBINAISONS / KOMBINATIONEN**

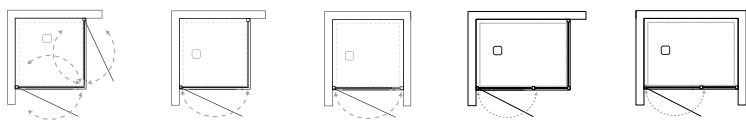

**PROFILI A MURO / WALL PROFILE / PERFIL DE PARED
PROFILÉS MURAUX / WANDPROFIL**

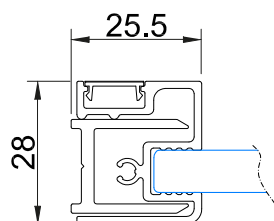







PRISMA 1.0

megius









2.0
PRISMA



Equilibrio Geometrico
Geometric balance
Balance geométrico
Balance géométrique
Geometrisches Gleichgewicht

prisma 2.0

Equilibrio Geometrico
Geometric balance
Balance geométrica
Balance géométrique
Geometrisches Gleichgewicht

PIVOT

VETRI TEMPERATI / TEMPERED GLASSES / CRISTAL TEMPLADO VERRES TREMPÉS / GETEMPERTE GLÄSER



specchio - mirror
espejo - miroir -
Glasspiegel

D (no protective)



trasparente - transparent
transparent - transparente
klarglas

F



extra chiaro - extra clear
extraclair - extraclaro - extra claro

Q



bronzo - bronze
bronce - bronce - bronze

1Z



extrachiaro flute - flute extra-clear
flute extra claro -flute extra-clair - flute
extra klar

NEW 2024 1X (6 mm)



extrachiaro satinato - satin extra-clear
mate extra claro - satinierter extra klar

1Q



fumè satinato - satin fumè
gris fumè - mat fumée - satinierter
Rauch

1A



extrachiaro fabric or - Fabric extra-clear or
Fabric extra claro or - Fabric extra-clair or
Fabric extra klar or

1T



extrachiaro fabric vr - Fabric extra-clear vr
Fabric extra claro vr - Fabric extra-clair vr
Fabric extra klar vr

1S

PROFILI / PROFILES PERFILES / PROFILS / PROFILEN



cromo brillante - brilliant chrome
cromo brillante - chrome brillant
Chrom glänzend

Q



nero - black
negro - schwarz - noir

Z



alluminio Spazzolato - brushed Aluminum -
aluminio Cepillado
aluminum Brossé - gebürstetes

F



finitura acciaio spazzolato - brushed steel
finish - acabado acero cepillado
inox brossé - Ausführung gebürst

3



grafite satinato - satin graphite
graphite mate - graphite mat
satinierter Graphite

NEW 2024 C



rame spazzolato - brushed copper
cobre cepillado - cuivre brossé - gebür-
stete Kupfer

9



oro rosé satinato - satin-finished rosé gold - oro
rosa mate - or rose mat - satinierter Rose'-Gold

4



bronzo lucido - polished bronze
bronce brillante - bronze brillantglänzende
Bronze

B



bronzo spazzolato - brushed bronze -
bronze cepillado
bronze brossé - gebürstete Bronze

8



bronzo satinato - satin bronze
bronze mate - bronze mat satinierter
Bronze

W



oro lucido - polished gold
oro brillante - or brilliant - gold glänzend

I



oro spazzolato - brushed gold
oro cepillado - or brossé - gebürstete Gold

7



oro rosé lucido - polished rosé gold
- oro rosa brillante -or rose brillant -
glänzende Rose'-Gold

D



bianco Opaco - Opaque white
blanco Opaco - blanc Opaque - Matt Weiß

E

ALTEZZA STANDARD STANDARD HEIGHT ALTURA ESTÁNDAR STANDARD HÖHE HAUTEUR STANDARD	h. 2000 mm
SPESSORE DEI VETRI GLASS THICKNESS ESPESOR DE VIDRIO GLASDICKE ÉPAISSEUR DU VERRE	8 mm
ALTEZZA DELLA MANIGLIA HANDLE HEIGHT ALTURA DE LA MANIJA HANDGRIFF HÖHE HAUTEUR DE LA POIGNÉE	320 mm
TRATTAMENTO PROTECTIVE PROTECTIVE TREATMENT TRATAMIENTO PROTECTOR PROTECTIVE BEHANDLUNG TRAITEMENT PROTECTIVE	OPTION

**MODELLI / MODELS / MODELOS
MODÈLES / MODELLE**

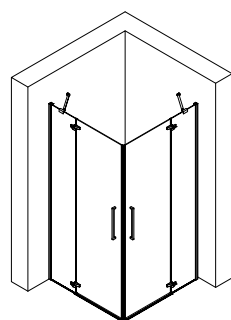

PRISMA 2.0 A 1/2

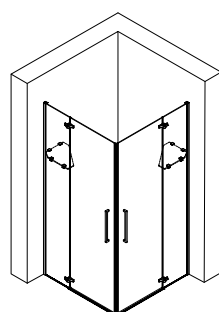

PRISMA 2.0 M 1/2

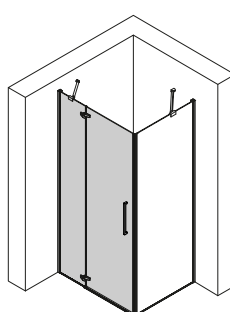

PRISMA 2.0 F00

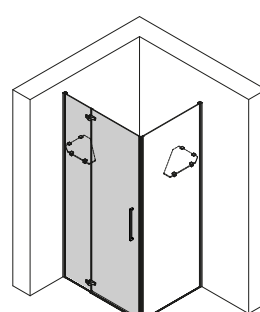

PRISMA 2.0 FM0

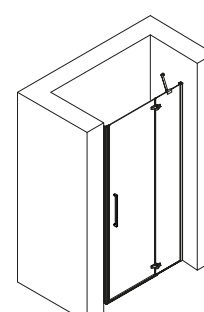

PRISMA 2.0 B1F

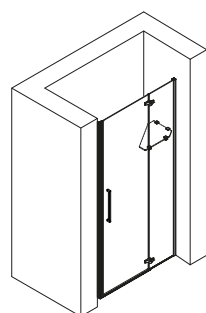

PRISMA 2.0 B1M

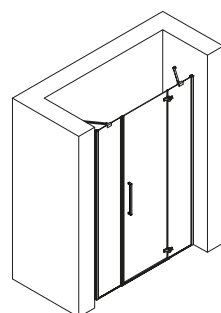

PRISMA 2.0 B2F

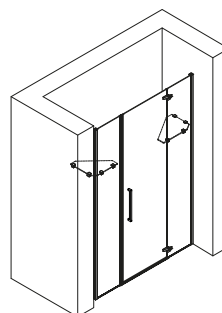

PRISMA 2.0 B2M

**COMBINAZIONI / COMBINATIONS
COMBINACIONES / COMBINAISONS / KOMBINATIONEN**

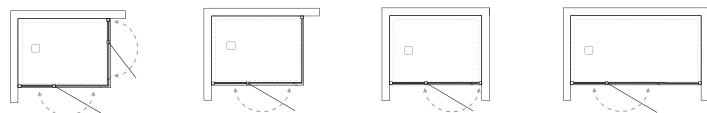

**PROFILI A MURO / WALL PROFILE / PERFIL DE PARED
PROFILÉS MURAUX / WANDPROFIL**

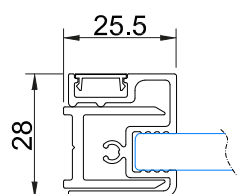



PRISMA B1F









WEB SERIES



Profilo tecnico, rotazione estrema
Technical profile, extreme rotation
Perfil técnico, rotación extrema
Profil technique, rotation extrême
Technisches Profil, extreme Rotation

web series

Profilo tecnico, rotazione estrema
Technical profile, extreme rotation
Perfil técnico, rotación extrema
Profil technique, rotation extrême
Technisches Profil, extreme Rotation

PIVOT

VETRI TEMPERATI / TEMPERED GLASSES / CRISTAL TEMPLADO VERRES TREMPÉS / GETEMPERTE GLÄSER



trasparente - transparent
transparent - transparente klarglas
F



serigraf. LINE - LINE serigr.
LINE Serigrafiado - LINE siebdruck
V



fumè - rauchglas
humo - fumado
N



+ *altre finiture vetro disponibili a listino su richiesta*
other glass finishes available on request
otros acabados de cristal disponibles bajo demanda
autres finitions de verre disponibles sur demande
Andere Glasausführungen auf Anfrage möglich



serigraf. STRIPE - STRIPE serigr.
STRIPE siebdruck - serigraf. STRIPE -
STRIPE serigr.
J

PROFILI / PROFILES PERFILES / PROFILS / PROFILEN



bianco Opaco - Opaque white
blanco Opaco - blanc Opaque - Matt Weiß
E



argento satinato - silver mat
plata satinado - argent satiné -
Silber matt
K



argento lucido - silver shining
plata brillante - argent brillant -
Silber glänzend
R

ALTEZZA STANDARD STANDARD HEIGHT ALTURA ESTÁNDAR STANDARD HÖHE HAUTEUR STANDARD	h. 1950 mm
SPESSORE DEI VETRI GLASS THICKNESS ESPEJOR DE VIDRIO GLASDICKE ÉPAISSEUR DU VERRE	6 mm
ALTEZZA DELLA MANIGLIA HANDLE HEIGHT ALTURA DE LA MANIJA HANDGRIFF HÖHE HAUTEUR DE LA POIGNÉE	160 mm
TRATTAMENTO PROTECTIVE PROTECTIVE TREATMENT TRATAMIENTO PROTECTOR PROTECTIVE BEHANDLUNG TRAITEMENT PROTECTIVE	OPTION

web 1.0

MODELLI / MODELS / MODELOS
MODÈLES / MODELLE

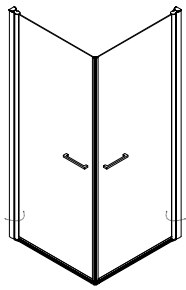

WEB 1.0 A 1/2

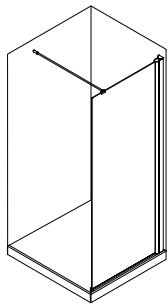

WEB 1.0 F

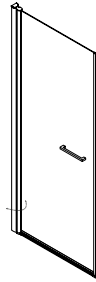

WEB 1.0 PB

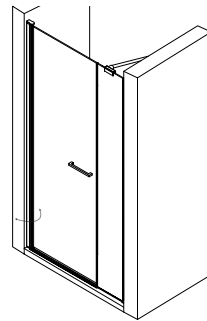

WEB 1.0 B1F

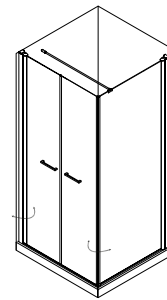

WEB 1.0 SAL

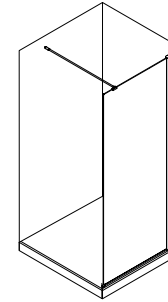

WEB 1.0 F1F

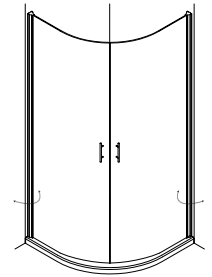

WEB 1.0 R2B

COMBINAZIONI / COMBINATIONS
COMBINACIONES / COMBINAISONS / KOMBINATIONEN

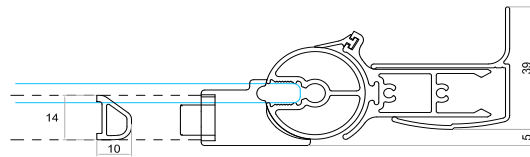
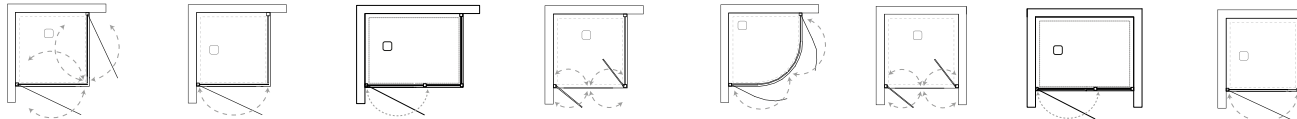

PROFILI A MURO / WALL PROFILE / PERFIL DE PARED
PROFILÉS MURAUX / WANDPROFIL

web 1.1

MODELLI / MODELS / MODELOS / MODÈLES / MODELLE

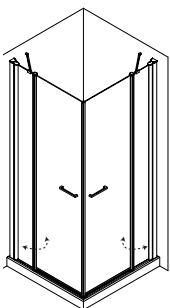

WEB 1.1 A 1/2

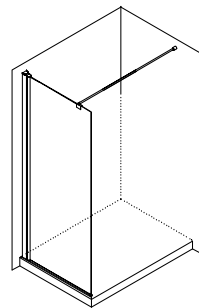

WEB 1.1 F

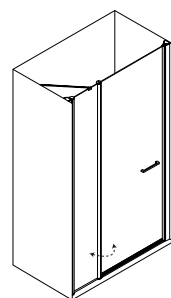

WEB 1.1 B1F

PROFILI A MURO / WALL PROFILE / PERFIL DE PARED
PROFILÉS MURAUX / WANDPROFIL

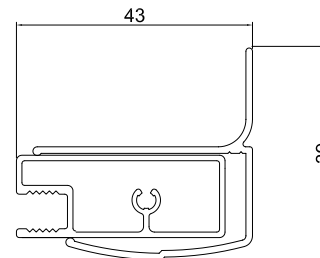

COMBINAZIONI / COMBINATIONS / COMBINACIONES / COMBINAISONS / KOMBINATIONEN

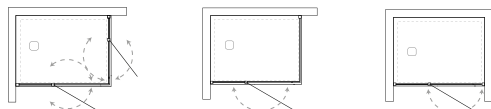

web 2.0

MODELLI / MODELS / MODELOS / MODÈLES / MODELLE

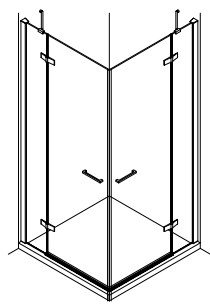

WEB 2.0 A 1/2

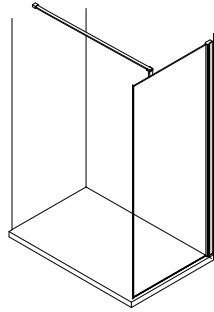

WEB 2.0 F

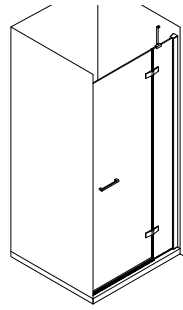

WEB 2.0 B1F

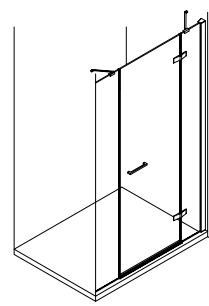

WEB 2.0 B2F

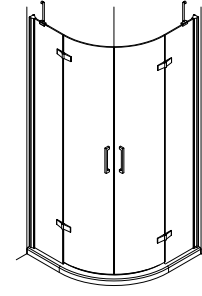

WEB 2.0 R2B

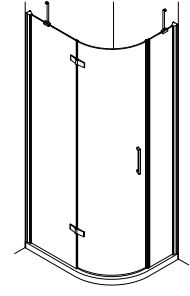

WEB 2.0 S1B

COMBINAZIONI / COMBINATIONS / COMBINACIONES / COMBINAISONS / KOMBINATIONEN

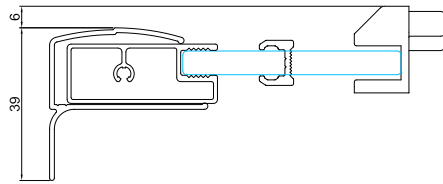
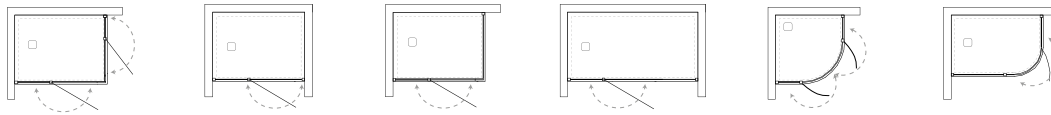

PROFILI A MURO / WALL PROFILE / PERFIL DE PARED
PROFILÉS MURAUX / WANDPROFIL

web 3.0

MODELLI / MODELS / MODELOS / MODÈLES / MODELLE

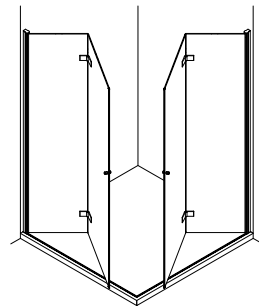

WEB 3.0 A 1/2

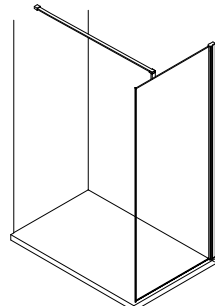

WEB 3.0 F

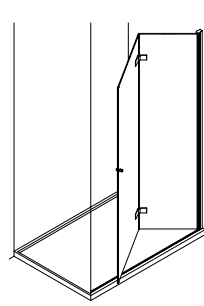

WEB 3.0 P1S

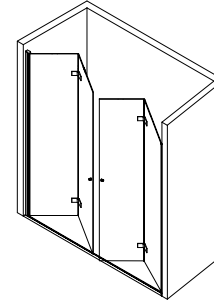

WEB 3.0 P2S

COMBINAZIONI / COMBINATIONS / COMBINACIONES / COMBINAISONS / KOMBINATIONEN

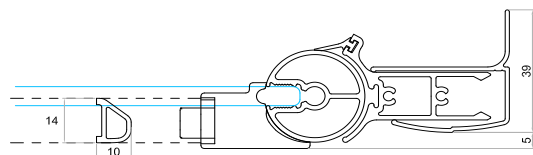
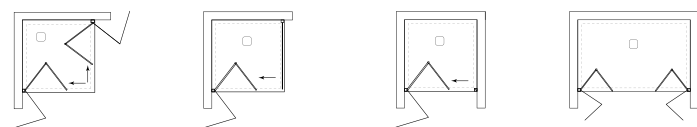

PROFILI A MURO / WALL PROFILE / PERFIL DE PARED
PROFILÉS MURAUX / WANDPROFIL

web 5.0

MODELLI / MODELS / MODELOS / MODÈLES / MODELLE

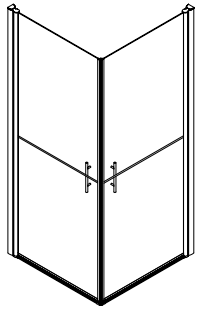

WEB 5.0 A 1/2

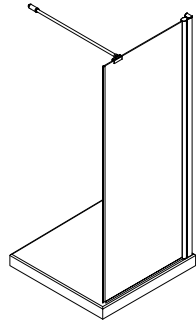

WEB 5.0 F

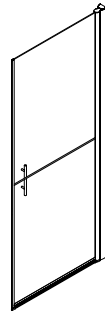

WEB 5.0 PB

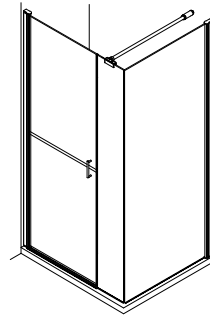

WEB 5.0 B1F

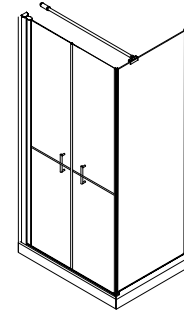

WEB 5.0 SAL

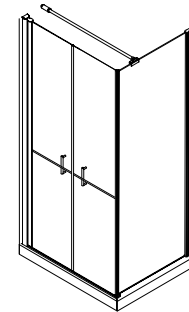

WEB 5.0 F1F

COMBINAZIONI / COMBINATIONS / COMBINACIONES / COMBINAISONS / KOMBINATIONEN

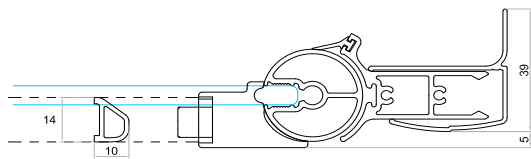
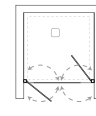
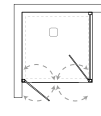
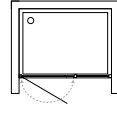
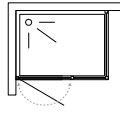
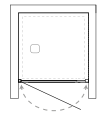
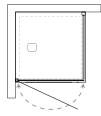
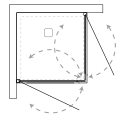

PROFILI A MURO / WALL PROFILE / PERFIL DE PARED
PROFILÉS MURAUX / WANDPROFIL



WEB 1.0 PBO





WEB 2.0 A 1/2



WEB 1.1











SOLO
DOCCIA
EVO PIVOT



Il vetro disegna nuovi confini nella cabina doccia
The glass draws new boundaries in the shower enclosure
El cristal traza nuevos límites en la cabina de ducha
Le verre dessine de nouvelles limites dans la cabine de douche
Das Glas zieht neue Grenzen in der Duschkabine

solodoccia evo

Il vetro disegna nuovi confini nella cabina doccia
The glass draws new boundaries in the shower enclosure
El cristal traza nuevos límites en la cabina de ducha
Le verre dessine de nouvelles limites dans la cabine de douche
Das Glas zieht neue Grenzen in der Duschkabine

PIVOT

VETRI TEMPERATI / TEMPERED GLASSES / CRISTAL TEMPLADO VERRES TREMPÉS / GETEMPERTE GLÄSER

 trasparente - transparent transparent - transparente klarglas F	 serigraf. LINE - LINE serigr. LINE Serigrafiado - LINE siebdruk V
 fumè - rauchglas humo - fumado N	 vetro riflettente - reflective glass vidrio reflejo - verre réfléchissant - reflektieren- des Glas S
 serigraf. STRIPE - STRIPE serigr. STRIPE siebdruk - serigraf. STRI- PE - STRIPE serigr. J	 extra chiaro - extra clear extraclair - extraclaro - extra claro Q

PROFILI / PROFILES PERFILES / PROFILS / PROFILEN

 bianco Opaco - Opaque white blanco Opaco - blanc Opaque - Matt Weiß E	 cromo brillante - brilliant chrome cromo brillante - chrome brillant Chrom glänzend Q
 nero - black negro - schwarz - noir Z	

ALTEZZA STANDARD STANDARD HEIGHT ALTURA ESTÁNDAR STANDARD HÖHE HAUTEUR STANDARD	h. 2100 mm
SPESSORE DEI VETRI GLASS THICKNESS ESPESOR DE VIDRIO GLASDICKE ÉPAISSEUR DU VERRE	8 mm
ALTEZZA DELLA MANIGLIA HANDLE HEIGHT ALTURA DE LA MANIJA HANDGRIFF HÖHE HAUTEUR DE LA POIGNÉE	198 mm
TRATTAMENTO PROTECTIVE PROTECTIVE TREATMENT TRATAMIENTO PROTECTOR PROTECTIVE BEHANDLUNG TRAITEMENT PROTECTIVE	INCLUDED

**MODELLI / MODELS / MODELOS
MODÈLES / MODELLE**

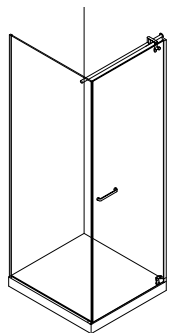

SOLODOCCIA EVO AB0

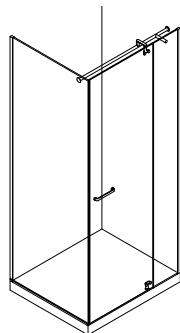

SOLODOCCIA EVO AB1

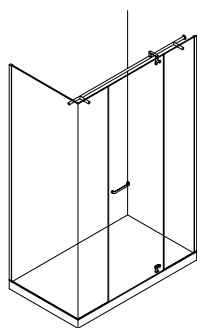

SOLODOCCIA EVO AB2

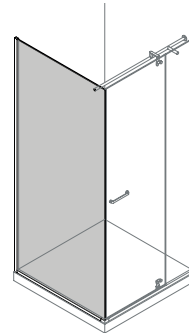

SOLODOCCIA EVO FB

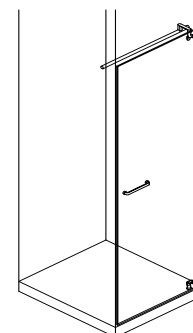

SOLODOCCIA EVO PB0

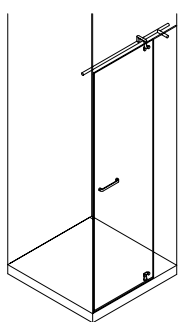

SOLODOCCIA EVO PB1

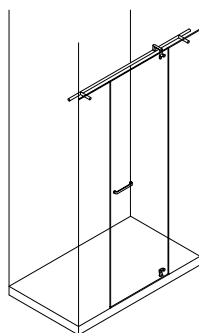

SOLODOCCIA EVO PB2

**COMBINAZIONI / COMBINATIONS
COMBINACIONES / COMBINAISONS / KOMBINATIONEN**

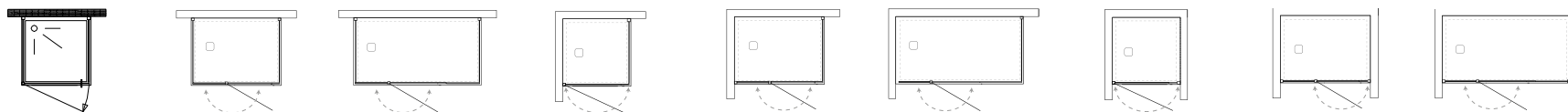

**PROFILI A MURO / WALL PROFILE / PERFIL DE PARED
PROFILÉS MURAU / WANDPROFIL**

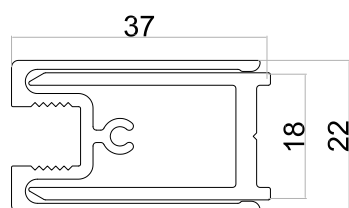







SOLODOCCIA EVO PIVOT AB1













SOLO
DOCCIA
EVO SLIDING



Il vetro disegna nuovi confini nella cabina doccia
The glass draws new boundaries in the shower enclosure
El cristal traza nuevos límites en la cabina de ducha
Le verre dessine de nouvelles limites dans la cabine de douche
Das Glas zieht neue Grenzen in der Duschkabine

solodoccia evo

Il vetro disegna nuovi confini nella cabina doccia
The glass draws new boundaries in the shower enclosure
El cristal traza nuevos límites en la cabina de ducha
Le verre dessine de nouvelles limites dans la cabine de douche
Das Glas zieht neue Grenzen in der Duschkabine

SLIDING

VETRI TEMPERATI / TEMPERED GLASSES / CRISTAL TEMPLADO VERRES TREMPÉS / GETEMPERTE GLÄSER

 trasparente - transparent transparent - transparente klarglas F	 serigraf. LINE - LINE serigr. LINE Serigrafiado - LINE siebdruck V
 fumè - rauchglas humo - fumado N	 vetro riflettente - reflective glass vidrio reflejo - verre réfléchissant - reflektieren- des Glas S
 serigraf. STRIPE - STRIPE serigr. STRIPE siebdruck - serigraf. STRI- PE - STRIPE serigr. J	 extra chiaro - extra clear extraclair - extraclaro - extra claro Q

PROFILI / PROFILES PERFILES / PROFILS / PROFILEN

 bianco Opaco - Opaque white blanco Opaco - blanc Opaque - Matt Weiß E	 cromo brillante - brilliant chrome cromo brillante - chrome brillant Chrom glänzend Q
 nero - black negro - schwarz - noir Z	

ALTEZZA STANDARD STANDARD HEIGHT ALTURA ESTÁNDAR STANDARD HÖHE HAUTEUR STANDARD	h. 2100 mm
SPESSORE DEI VETRI GLASS THICKNESS ESPESOR DE VIDRIO GLASDICKE ÉPAISSEUR DU VERRE	8 mm
ALTEZZA DELLA MANIGLIA HANDLE HEIGHT ALTURA DE LA MANIJA HANDGRIFF HÖHE HAUTEUR DE LA POIGNÉE	198 mm
TRATTAMENTO PROTECTIVE PROTECTIVE TREATMENT TRATAMIENTO PROTECTOR PROTECTIVE BEHANDLUNG TRAITEMENT PROTECTIVE	INCLUDED

**MODELLI / MODELS / MODELOS
MODÈLES / MODELLE**

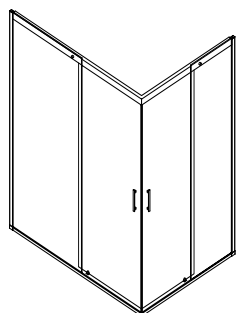

SOLODOCCIA EVO A 1/2

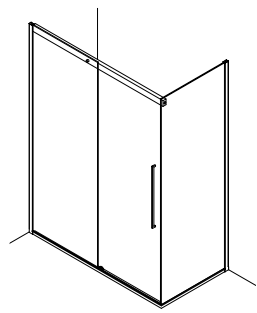

SOLODOCCIA EVO A1S

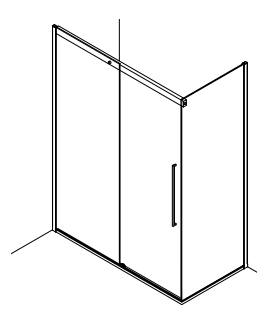

SOLODOCCIA EVO FS0

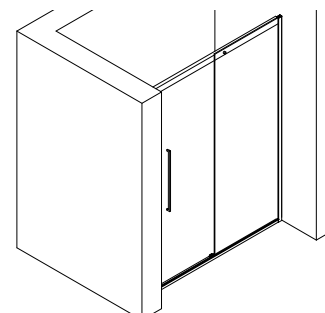

SOLODOCCIA EVO P1S

**COMBINAZIONI / COMBINATIONS
COMBINACIONES / COMBINAISONS / KOMBINATIONEN**



**PROFILI A MURO / WALL PROFILE / PERFIL DE PARED
PROFILÉS MURAUX / WANDPROFIL**

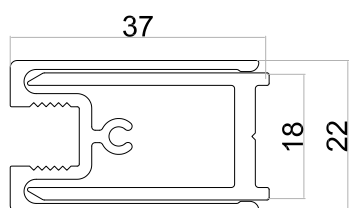

SOLODOCCIA EVO SLIDING P1S









SOLODOCCIA SLIDING FS0



SOLODOCCIA P1S

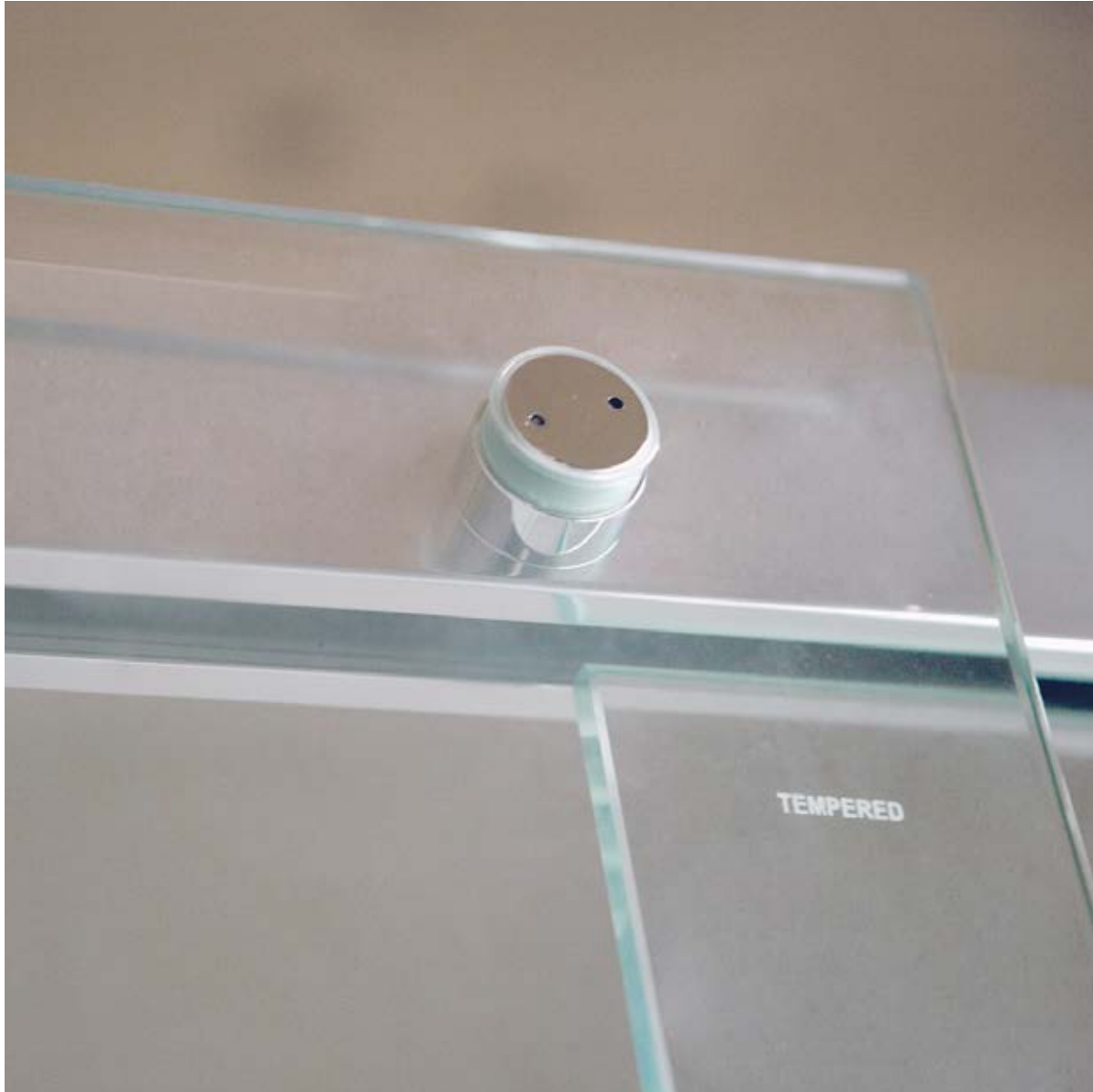



SOLODOCCIA EVO SLIDING AIS







La doccia scorrevole sposa la leggerezza del vetro
The sliding shower combines the lightness of glass
La ducha deslizando combina la ligereza del vidrio
La douche coulissante allie la légèreté du verre
Die Schiebedusche vereint die Leichtigkeit von Glas

light

La doccia scorrevole sposa la leggerezza del vetro
The sliding shower combines the lightness of glass
La ducha deslizante combina la ligereza del vidrio
La douche coulissante allie la légèreté du verre
Die Schiebedusche vereint die Leichtigkeit von Glas

SLIDING

VETRI TEMPERATI / TEMPERED GLASSES / CRISTAL TEMPLADO VERRES TREMPÉS / GETEMPERTE GLÄSER



trasparente - transparent
transparent - transparente klarglas

F



vetro riflettente - reflective glass
vidrio reflejo - verre réfléchissant - reflektierendes Glas

S



fumè - rauchglas
humo - fumado

N



serigraf. LINE - LINE serigr.
LINE Serigrafado - LINE siebdruck

V



serigraf. STRIPE - STRIPE serigr.
STRIPE siebdruck - serigraf. STRIPE -
STRIPE serigr.

J

PROFILI / PROFILES PERFILES / PROFILS / PROFILEN



bianco RAL9010 - white RAL9010
blanco RAL9010 - blanc RAL9010 - Weiß RAL9010

L



cromo brillante - brilliant chrome
cromo brillante - chrome brillant
Chrom glänzend

Q

ALTEZZA STANDARD STANDARD HEIGHT ALTURA ESTÁNDAR STANDARD HÖHE HAUTEUR STANDARD	h. 2000 mm
SPESSORE DEI VETRI GLASS THICKNESS ESPESOR DE VIDRIO GLASDICKE ÉPAISSEUR DU VERRE	8 mm
ALTEZZA DELLA MANIGLIA HANDLE HEIGHT ALTURA DE LA MANIJA HANDGRIFF HÖHE HAUTEUR DE LA POIGNÉE	160 mm
TRATTAMENTO PROTECTIVE PROTECTIVE TREATMENT TRATAMIENTO PROTECTOR PROTECTIVE BEHANDLUNG TRAITEMENT PROTECTIVE	INCLUDED

**MODELLI / MODELS / MODELOS
MODÈLES / MODELLE**

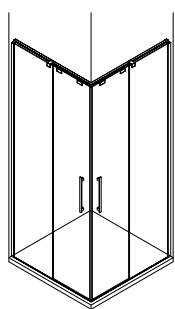

LIGHT A 1/2

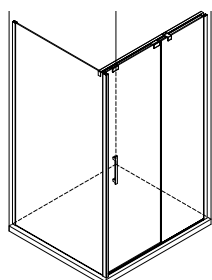

LIGHT PSA

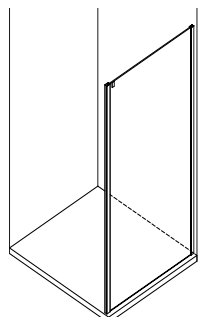

LIGHT LSA

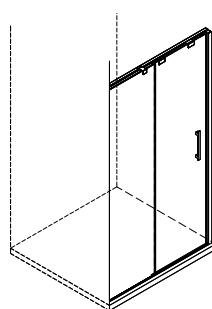

LIGHT PSC 1P

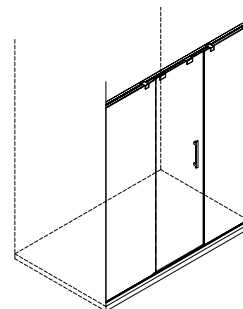

LIGHT PC0

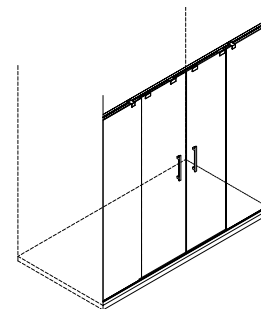

LIGHT PSC 2P

**COMBINAZIONI / COMBINATIONS
COMBINACIONES / COMBINAISONS / KOMBINATIONEN**

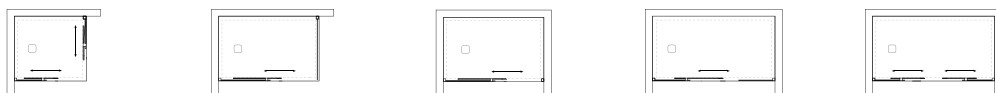

**PROFILI A MURO / WALL PROFILE / PERFIL DE PARED
PROFILÉS MURAUX / WANDPROFIL**

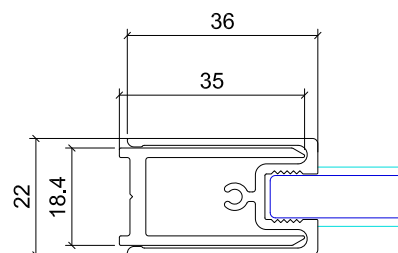





LIGHT PC0



LIGHT PSA



LIGHT PSA







ILLUSION



Il box doccia con lo scorrimento inferiore disponibile in molteplici finiture
The shower enclosure with lower sliding available in multiple finishes
La cabina de ducha con corredera inferior disponible en múltiples acabados
La cabine de douche avec coulissement inférieur disponible en plusieurs finitions
Die Duschkabine mit unterer Schiebetür ist in mehreren ausführungen erhältlich

illusion

Il box doccia con lo scorrimento inferiore disponibile in molteplici finiture
 The shower enclosure with lower sliding available in multiple finishes
 La cabina de ducha con corredera inferior disponible en múltiples acabados
 La cabine de douche avec coulissement inférieur disponible en plusieurs finitions
 Die Duschkabine mit unterer Schiebetür ist in mehreren ausführungen erhältlich

SLIDING

VETRI TEMPERATI / TEMPERED GLASSES / CRISTAL TEMPLADO VERRÉS TREMPÉS / GETEMPERTE GLÄSER



specchio - mirror
 espejo - miroir -
 Glasspiegel

D (no protective)



trasparente - transparent
 transparent - transparente klarglas

F



extrachiaro satinato - satin extra-clear
 mate extra claro - satinierte extra klar

1Q



fumè satinato - satin fumè
 gris fumè - mat fumée - satinierte Rauch

1A



oro satinato - satin gold
 oro mate - mat gold - satinierte Gold

1H



extra chiaro - extra clear
 extraclair - extraclaro - extra claro

Q



specchio blu - blue mirror
 espejo azul - bleu miroir - blauer Spiegel

1K (no protective)

PROFILI / PROFILES PERFILES / PROFILS / PROFILEN



cromo brillante - brilliant chrome
 cromo brillante - chrome brillant
 Chrom glänzend

Q



nero - black
 negro - schwarz - noir

Z



finitura acciaio spazzolato - brushed
 steel finish - acabado acero cepillado
 inox brossé - Ausführung gebürst

3



grafite satinato - satin graphite
 graphite mate - graphite mat
 satinierte Graphite

NEW 2024

C



rame spazzolato - brushed copper
 cobre cepillado - cuivre brossé -
 gebürstete Kupfer

9



oro rosè satinato - satin-finished rosé
 gold - oro rosa mate - or rose mat -
 satinierte Rose'-Gold

4



bianco Opaco - Opaque white
 blanco Opaco - blanc Opaque - Matt Weiß

E



bronzo lucido - polished bronze
 bronze brillante - bronze brillantglänzende
 Bronze

B



bronzo spazzolato - brushed bronze -
 bronze cepillado
 bronze brossé - gebürstete Bronze

8



bronzo satinato - satin bronze
 bronze mate - bronze mat satinierte
 Bronze

W



oro lucido - polished gold
 oro brillante - or brillant - gold
 glänzend

I



oro spazzolato - brushed gold
 oro cepillado - or brossé - gebürstete
 Gold

7



oro rosè lucido - polished rosé gold - oro
 rosa brillante -or rose brillant - glänzende
 Rose'-Gold

D

ALTEZZA STANDARD STANDARD HEIGHT ALTURA ESTÁNDAR STANDARD HÖHE HAUTEUR STANDARD	h. 2003 mm
SPESSORE DEI VETRI GLASS THICKNESS ESPESOR DE VIDRIO GLASDICKE ÉPAISSEUR DU VERRE	8+8 mm
ALTEZZA DELLA MANIGLIA HANDLE HEIGHT ALTURA DE LA MANIJA HANDGRIFF HÖHE HAUTEUR DE LA POIGNÉE	/
TRATTAMENTO PROTECTIVE PROTECTIVE TREATMENT TRATAMIENTO PROTECTOR PROTECTIVE BEHANDLUNG TRAITEMENT PROTECTIVE	INCLUDED

**MODELLI / MODELS / MODELOS
MODÈLES / MODELLE**

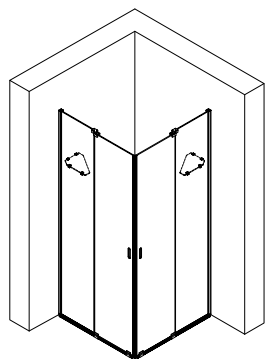

ILLUSION A1/2

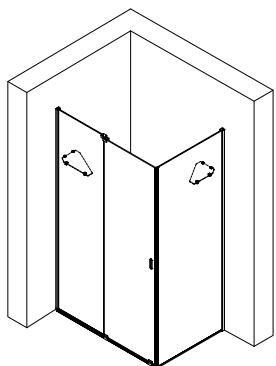

ILLUSION A1S+FSM

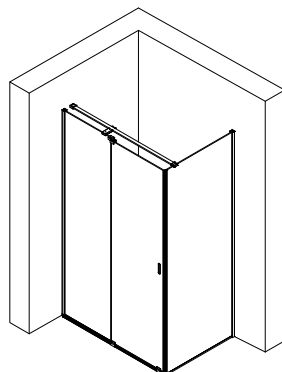

ILLUSION A1C+FSO

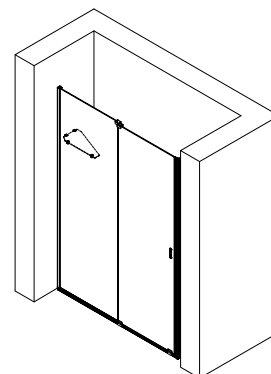

ILLUSION P1S

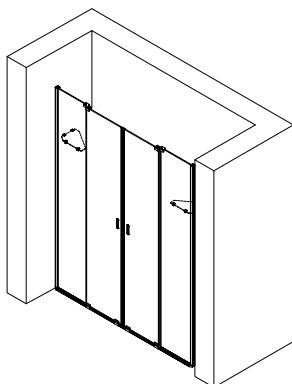

ILLUSION P2S

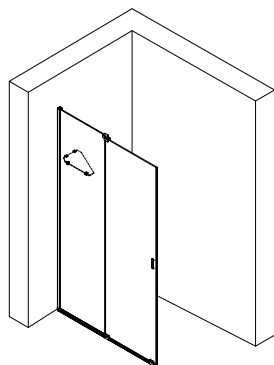

ILLUSION SA0 - SEPARÈ

**COMBINAZIONI / COMBINATIONS
COMBINACIONES / COMBINAISONS / KOMBINATIONEN**

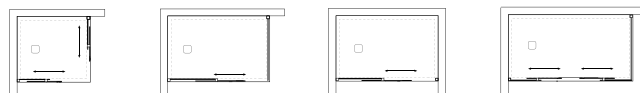

**PROFILI A MURO / WALL PROFILE / PERFIL DE PARED
PROFILÉS MURAUX / WANDPROFIL**

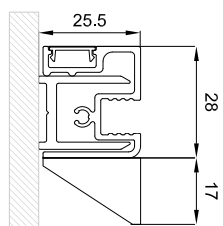



















ZENIXL



Il box doccia con il profilo più minimal di sempre + soft-closing
The shower enclosure with the most minimalist profile ever + soft-closing
La cabina de ducha con el perfil más minimalista de la historia + soft-closing
La cabine de douche au profil le plus minimaliste de tous les temps + soft-closing
Die Duschkabine mit dem minimalistischsten Profil aller Zeiten + soft-closing

zen XL

Il box doccia con il profilo più minimal di sempre + soft-closing
 The shower enclosure with the most minimalist profile ever + soft-closing
 La cabina de ducha con el perfil más minimalista de la historia + soft-closing
 La cabine de douche au profil le plus minimaliste de tous les temps + soft-closing
 Die Duschkabine mit dem minimalistischsten Profil aller Zeiten + soft-closing

PIVOT | SLIDING

VETRI TEMPERATI / TEMPERED GLASSES / CRISTAL TEMPLADO VERRES TREMPÉS / GETEMPERTE GLÄSER

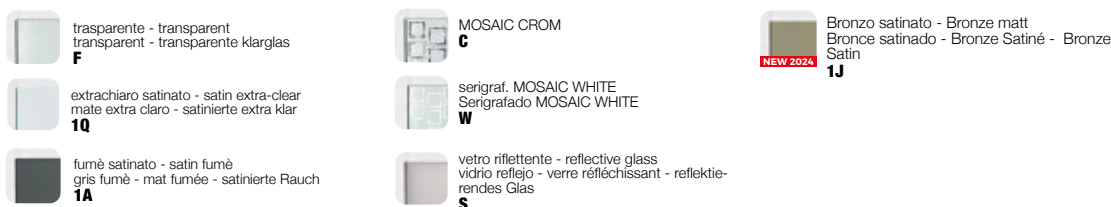

PROFILI / PROFILES PERFILES / PROFILS / PROFILEN



ALTEZZA STANDARD STANDARD HEIGHT ALTURA ESTÁNDAR STANDARD HÖHE HAUTEUR STANDARD	h. 2000 mm
SPESSORE DEI VETRI GLASS THICKNESS ESPESOR DE VIDRIO GLASDICKE ÉPAISSEUR DU VERRE	8 mm
ALTEZZA DELLA MANIGLIA HANDLE HEIGHT ALTURA DE LA MANIJA HANDGRIFF HÖHE HAUTEUR DE LA POIGNÉE	580 mm
TRATTAMENTO PROTECTIVE PROTECTIVE TREATMENT TRATAMIENTO PROTECTOR PROTECTIVE BEHANDLUNG TRAITEMENT PROTECTIVE	OPTION

**MODELLI / MODELS / MODELOS
MODÈLES / MODELLE**

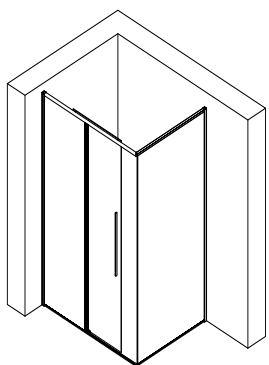

ZEN XL K1S + FS0

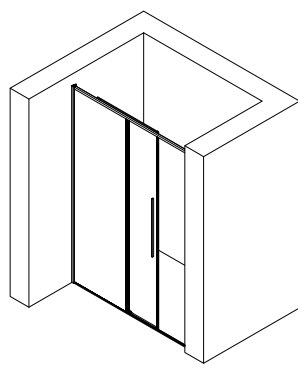

ZEN XL P1K

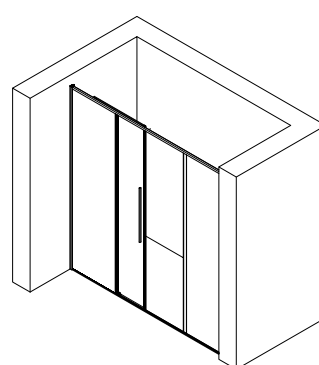

ZEN XL PCK

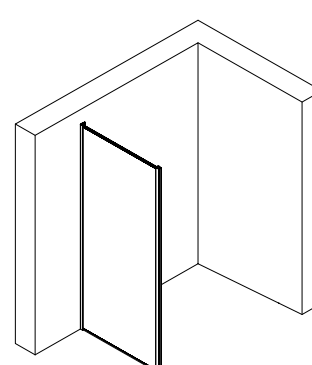

ZEN XL F00

**COMBINAZIONI / COMBINATIONS
COMBINACIONES / COMBINAISONS / KOMBINATIONEN**

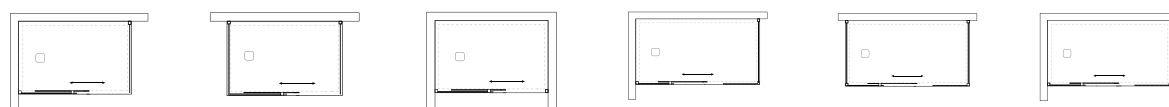

ZEN XL K1S+FSO



ZEN XL K1S+FSO







ZEN



Il box doccia con profilo più minimal di sempre
The shower enclosure with the most minimalist profile ever
La cabina de ducha con el perfil más minimalista de la historia
La cabine de douche au profil le plus minimaliste de tous les temps
Die Duschkabine mit dem minimalistischsten Profil aller Zeiten

zen

Il box doccia con profilo più minimal di sempre
 The shower enclosure with the most minimalist profile ever
 La cabina de ducha con el perfil más minimalista de la historia
 La cabine de douche au profil le plus minimaliste de tous les temps
 Die Duschkabine mit dem minimalistischsten Profil aller Zeiten

PIVOT | SLIDING

VETRI TEMPERATI / TEMPERED GLASSES / CRISTAL TEMPLADO VERRES TREMPÉS / GETEMPERTE GLÄSER

 trasparente - transparent
 transparent - transparente
 Klarglas

F

 vetro riflettente - reflective glass
 vidrio reflejo - verre réfléchissant -
 reflektierendes Glas

S

 opaline - opaline
 opalino - opalin - opalglas

O

 bronzo - bronze
 bronce - bronze - bronze

1Z

 extrachiaro fabric or - Fabric extra-clear or
 Fabric extra claro or - Fabric extra-clair or
 Fabric extra klar or

1T

 extrachiaro fabric vr - Fabric extra-clear vr
 Fabric extra claro vr - Fabric extra-clair vr
 Fabric extra klar vr

1S

 extrachiaro flute - flute extra-clear
 flute extra claro -flute extra-clair - flute
 extra klar

NEW 2024

1X (6 mm)

 fumè satinato - satin fumè
 gris fumè - mat fumée - satinierte
 Rauch

1A



MOSAIC CROM

C



serigraf. MOSAIC WHITE
 Serigrafado MOSAIC WHITE

W

PROFILI / PROFILES PERFILES / PROFILS / PROFILEN

 cromo brillante - brilliant chrome
 cromo brillante - chrome brillant
 Chrom glänzend

Q

 nero - black
 negro - schwarz - noir

Z

 finitura acciaio spazzolato - brushed
 steel finish - acabado acero cepillado
 inox brossé - Ausführung gebürs

3

 grafite satinato - satin graphite
 graphite mate - graphite mat
 satinierte Graphite

NEW 2024

C

 alluminio Spazzolato - brushed Aluminum - aluminio
 Cepillado - aluminium Brossé - gebürstetes

F

 bronzo lucido - polished bronze
 bronze brillante - bronze brillantglänzende
 Bronze

B

 bronzo spazzolato - brushed bronze - bronze
 cepillado
 bronze brossé - gebürstete Bronze

8

 bronzo satinato - satin bronze
 bronze mate - bronze mat satinierte Bronze

W

 oro lucido - polished gold
 oro brillante - or brillant - gold glänzend

I

 oro spazzolato - brushed gold
 oro cepillado - or brossé - gebürstete Gold

7

 rame spazzolato - brushed
 copper
 cobre cepillado - cuivre brossé -
 gebürstete Kupfer

9

 oro rosè satinato - satin-finished
 rosé gold - oro rosa mate - or rose
 mat - satinierte Rose'-Gold

4

 oro rosè lucido - polished rosé gold
 - oro rosa brillante - or rose brillant -
 glänzende Rose'-Gold

D

 bianco Opaco - Opaque white
 blanco Opaco - blanc Opaque - Matt Weiß

E

ALTEZZA STANDARD STANDARD HEIGHT ALTURA ESTÁNDAR STANDARD HÖHE HAUTEUR STANDARD	h. 2000 mm
SPESSORE DEI VETRI GLASS THICKNESS ESPESOR DE VIDRIO GLASDICKE ÉPAISSEUR DU VERRE	6+6 mm
ALTEZZA DELLA MANIGLIA HANDLE HEIGHT ALTURA DE LA MANIJA HANDGRIFF HÖHE HAUTEUR DE LA POIGNÉE	580 mm
TRATTAMENTO PROTECTIVE PROTECTIVE TREATMENT TRATAMIENTO PROTECTOR PROTECTIVE BEHANDLUNG TRAITEMENT PROTECTIVE	OPTION

**MODELLI / MODELS / MODELOS
MODÈLES / MODELLE**

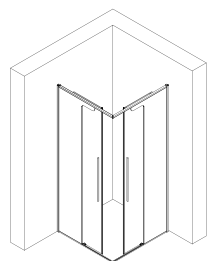

ZEN A 1/2

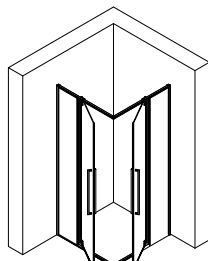

ZEN B 1/2

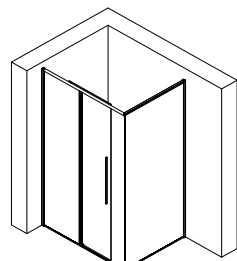

ZEN A1S + FS0

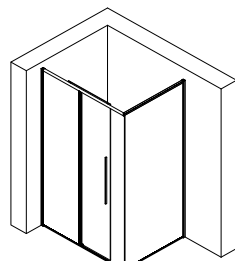

ZEN A1S + FSY

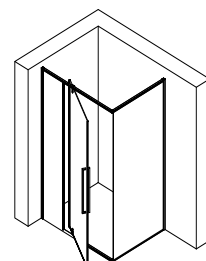

ZEN A1B + FB

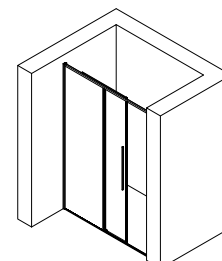

ZEN P1S

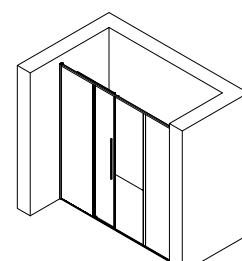

ZEN PCS

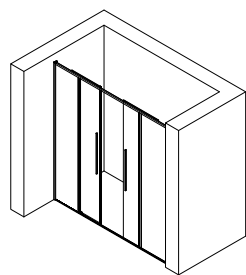

ZEN P2S

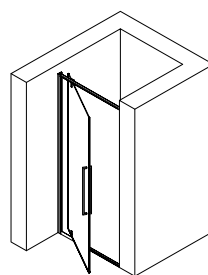

ZEN PV

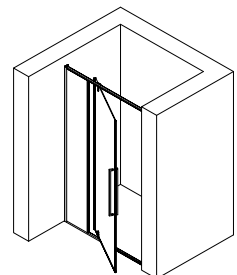

ZEN PVF

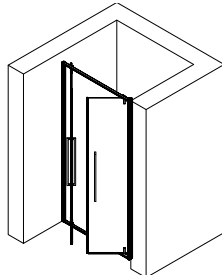

ZEN SAL

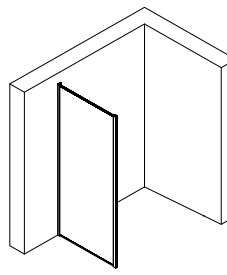

ZEN F

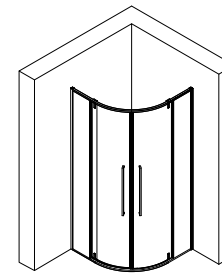

ZEN R2B

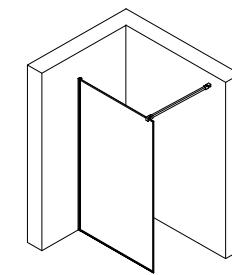

ZEN SA0 - SEPARÉ

**COMBINAZIONI / COMBINATIONS
COMBINACIONES / COMBINAISONS / KOMBINATIONEN**

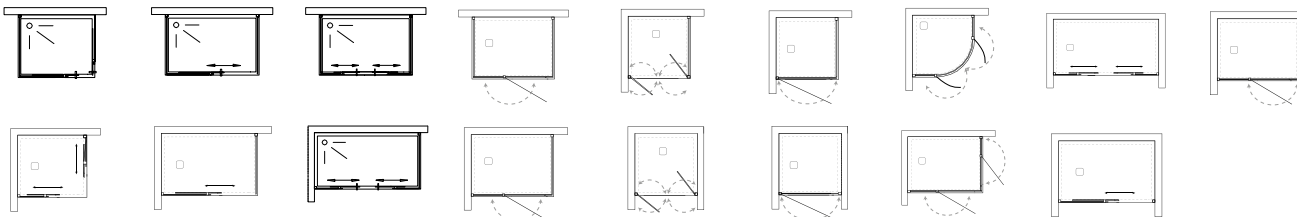

**PROFILI A MURO / WALL PROFILE / PERFIL DE PARED
PROFILÉS MURAUX / WANDPROFIL**

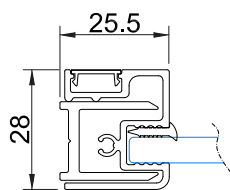

ANGOLO - CORNER - ANGLE - ÁNGULO -
ÂNGULO

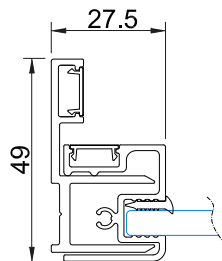

NICCHIA - NICHE - NICHE - NICHOS

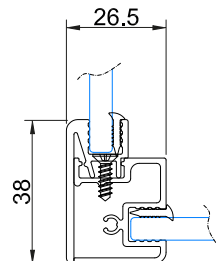

PROFILO DI ABBINAMENTO - CONJUNCTION PROFILE
PERFIL DE ENLACE - PROFIL DE LIAISON - VERBINDUNG
PROFIL







ZEN SAO



ZEN P1S + ZEN P1S





ZEN PV









ZEN PVF+F











MORE

LIVE









Molto più di una semplice doccia
Much more than just a shower enclosure
Mucho más que una ducha
Beaucoup plus qu'une simple douche
Viel mehr als nur eine Dusche

more live

Molto più di una semplice doccia
Much more than just a shower enclosure
Mucho más que una ducha
Beaucoup plus qu'une simple douche
Viel mehr als nur eine Dusche

PIVOT | SLIDING

VETRI TEMPERATI / TEMPERED GLASSES / CRISTAL TEMPLADO VERRES TREMPÉS / GETEMPERTE GLÄSER

 trasparente - transparent transparent - transparente klarglas F	 cincillà L
 orange T	 serigraf. LINE - LINE serigr. LINE Serigrafado - LINE siebdruck V
 opaline - opaline opalino - opalin - opalglas O	 serigraf. STRIPE - STRIPE serigr. STRIPE siebdruck - serigraf. STRIPE - STRIPE serigr. J
 <i>altre finiture vetro disponibili a listino su richiesta other glass finishes available on request otros acabados de cristal disponibles bajo demanda autres finitions de verre disponibles sur demande Andere Glasausführungen auf Anfrage möglich</i>	

PROFILI / PROFILES PERFILES / PROFILS / PROFILEN

 bianco Opaco - Opaque white blanco Opaco - blanc Opaque - Matt Weiß E	 argento satinato - silver mat plata satinado - argent satiné - Silber matt K
 argento lucido - silver shining plata brillante - argent brillant - Silber glänzend R	

ALTEZZA STANDARD STANDARD HEIGHT ALTURA ESTÁNDAR STANDARD HÖHE HAUTEUR STANDARD	h. 1950 mm
SPESSORE DEI VETRI GLASS THICKNESS ESPESOR DE VIDRIO GLASDICKE ÉPAISSEUR DU VERRE	6+8 mm
ALTEZZA DELLA MANIGLIA HANDLE HEIGHT ALTURA DE LA MANIJA HANDGRIFF HÖHE HAUTEUR DE LA POIGNÉE	160 mm
TRATTAMENTO PROTECTIVE PROTECTIVE TREATMENT TRATAMIENTO PROTECTOR PROTECTIVE BEHANDLUNG TRAITEMENT PROTECTIVE	OPTION

MODELLI / MODELS / MODELOS
MODÈLES / MODELLE

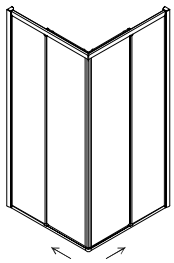

**MORE LIVE K
SOFTCLOSING**

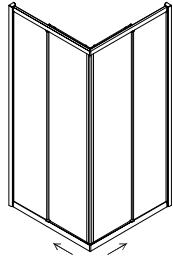

MORE LIVE A

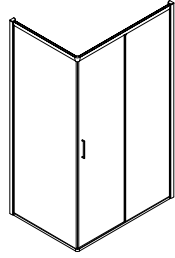

**MORE LIVE A1K + FS
SOFTCLOSING**

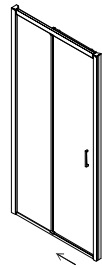

**MORE LIVE P1K
SOFTCLOSING**

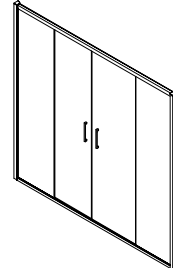

**MORE LIVE P2K
SOFTCLOSING**

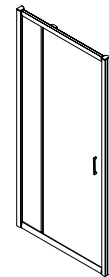

MORE LIVE PVF



MORE LIVE PV

MORE LIVE Z

MORE LIVE A1S + FS

MORE LIVE P1S

MORE LIVE P2S

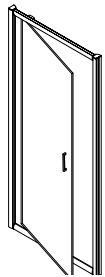

MORE LIVE PS

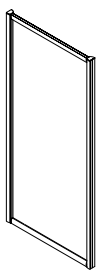

MORE LIVE L

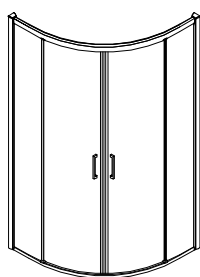

**MORE LIVE
ROUND 2P**

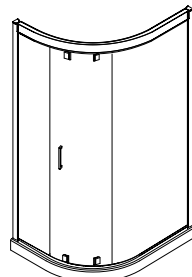

**MORE LIVE
SWIM**

COMBINAZIONI / COMBINATIONS
COMBINACIONES / COMBINAISONS / KOMBINATIONEN

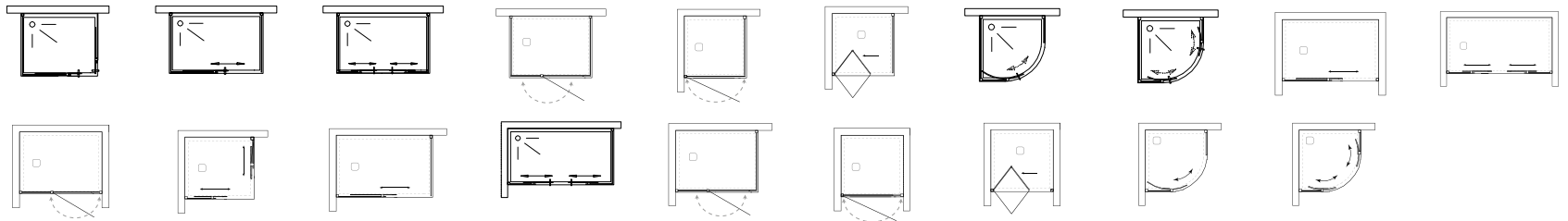

PROFILI A MURO / WALL PROFILE / PERFIL DE PARED
PROFILÉS MURAUX / WANDPROFIL

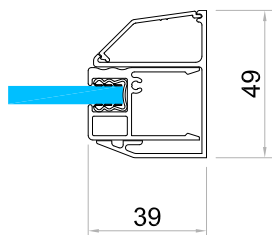





MORELIVE PVO







LIVE

TOP



Una doccia per vivere alla grande
A shower enclosure to live best
Una mampara de ducha para vivir a lo grande
Une douche pour vivre grand
Eine Dusche, um groß zu leben

live top

Una doccia per vivere alla grande
A shower enclosure to live best
Una mampara de ducha para vivir a lo grande
Une douche pour vivre grand
Eine Dusche, um groß zu leben

PIVOT | SLIDING

VETRI TEMPERATI / TEMPERED GLASSES / CRISTAL TEMPLADO VERRES TREMPÉS / GETEMPERTE GLÄSER



trasparente - transparent
transparent - transparente klarglas
F



orange
T



opaline - opaline
opalin - opaco - opalglas
H



fumè satinato - satin fumè
gris fumè - mat fumée - satinierte Rauch
1F

PROFILI / PROFILES PERFILES / PROFILS / PROFILEN



bianco RAL9010 - white RAL9010
blanco RAL9010 - blanc RAL9010 - Weiß RAL9010
L



nero - black
negro - schwarz - noir
Z



argento lucido - silver shining
plata brillante - argent brillant - Silber glänzend
R

ALTEZZA STANDARD STANDARD HEIGHT ALTURA ESTÁNDAR STANDARD HÖHE HAUTEUR STANDARD	h. 1950 mm
SPESSORE DEI VETRI GLASS THICKNESS ESPESOR DE VIDRIO GLASDICKE ÉPAISSEUR DU VERRE	6+6 mm
ALTEZZA DELLA MANIGLIA HANDLE HEIGHT ALTURA DE LA MANIJA HANDGRIFF HÖHE HAUTEUR DE LA POIGNÉE	320 mm
TRATTAMENTO PROTECTIVE PROTECTIVE TREATMENT TRATAMIENTO PROTECTOR PROTECTIVE BEHANDLUNG TRAITEMENT PROTECTIVE	OPTION

**MODELLI / MODELS / MODELOS
MODÈLES / MODELLE**

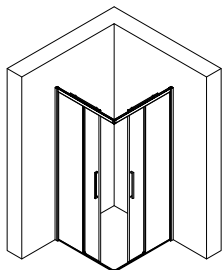

LIVE TOP A 1/2

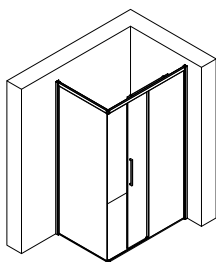

LIVE TOP A1S+FS0

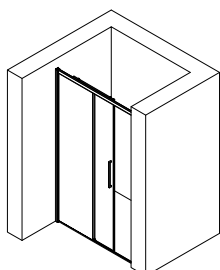

LIVE TOP P1S

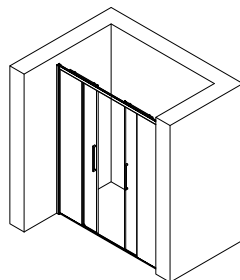

LIVE TOP P2S

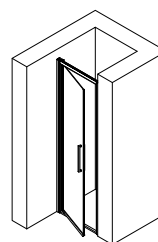

LIVE TOP PV0

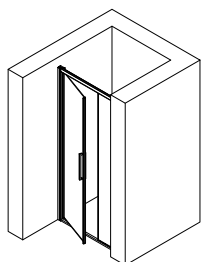

LIVE TOP PVF

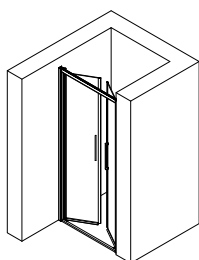

LIVE TOP SAL

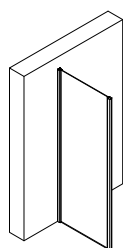

LIVE TOP F00

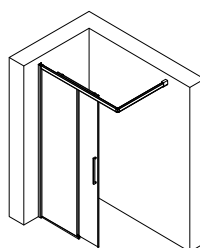

LIVE TOP SA0 SEPARÈ

**COMBINAZIONI / COMBINATIONS
COMBINACIONES / COMBINAISONS / KOMBINATIONEN**

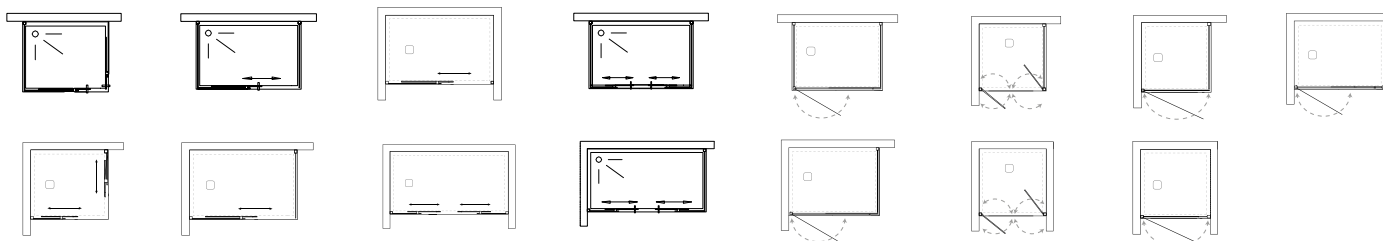

**PROFILI A MURO / WALL PROFILE / PERFIL DE PARED
PROFILÉS MURAUX / WANDPROFIL**

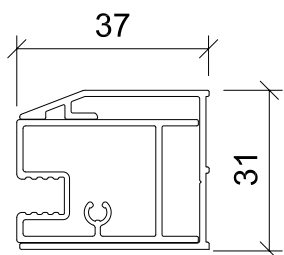



LIVE TOP A1/2



LIVE TOP P1S





LIVE TOP AIS+FSO





ECLIPSE

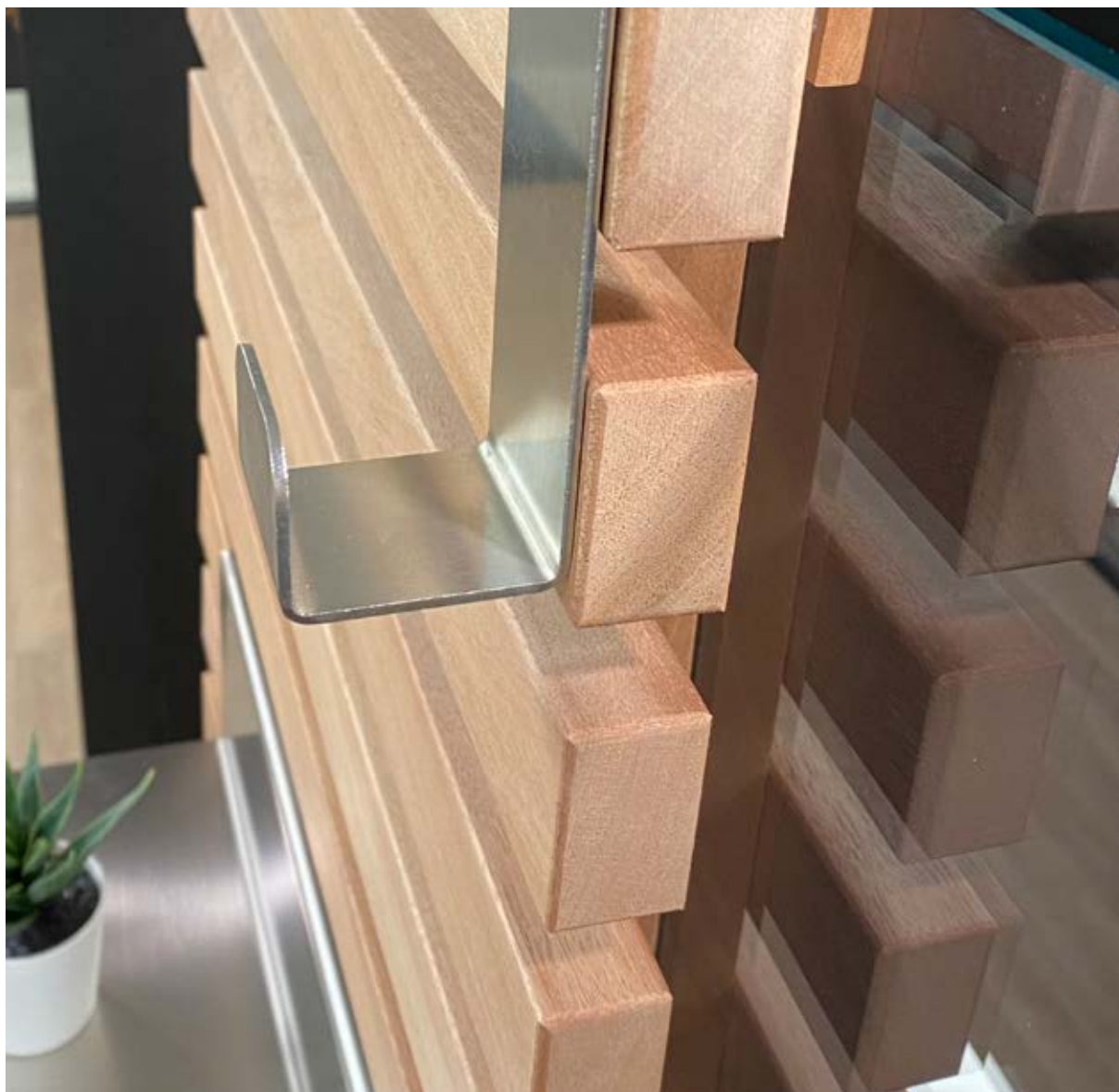

Un velo di arredamento per la tua doccia
A touch of furniture for your shower
Un toque de decoración para tu ducha
Une touche de décor pour votre douche
Ein Hauch von Dekor für Ihre Dusche

eclipse

Eclipse è un articolo di arredamento doccia componibile: è possibile installarlo singolarmente con altezza 90 cm oppure ordinando n° 2 pezzi si possono assemblare creando un'unica soluzione alta 180 cm. Eclipse è installabile su lastre di vetro senza profilo superiore. L'installazione è in appoggio al vetro e quindi facilmente rimovibile.

Eclipse is a modular shower furniture item: you can install it individually with a height of 90 cm or by ordering 2 pieces can be assembled creating a single solution of 180 cm. Eclipse can be installed on glass plates without a top profile. The installation rests on the glass and is therefore easily removable.

Eclipse es un artículo de muebles de ducha componible: se puede instalar individualmente con una altura de 90 cm o ordenando n° 2 piezas se pueden ensamblar creando una solución de 180 cm. Eclipse se puede instalar en placas de vidrio sin perfil superior. La instalación descansa sobre el vidrio y por lo tanto se extrae fácilmente.

Eclipse est un meuble de douche modulaire: il est possible de l'installer individuellement avec une hauteur de 90 cm ou, en commandant 2 pièces, vous pouvez l'assembler pour créer une solution unique de 180 cm. Eclipse peut être installé sur des plaques de verre sans profil supérieur. L'installation repose sur le verre et donc facilement démontable.

Eclipse ist ein kombinierbares Duscharmöbel: Sie können es einzeln in der Höhe 90cm montieren oder bei der Bestellung n° 2 Stück können Sie eine Lösung von 180cm herstellen. Eclipse kann auf Glasplatten ohne Profil installiert werden. Die Installation ruht auf dem Glas und ist daher leicht abnehmbar.

MODELLI / MODELS / MODELOS / MODÈLES / MODELLE

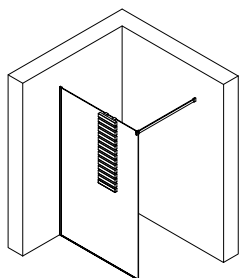

ECLIPSE S - N°1 PZ
30X90 CM

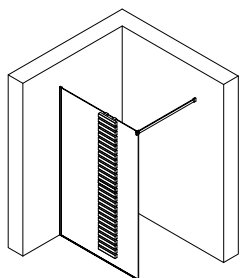

ECLIPSE S - N°2 PZ
30X180 CM

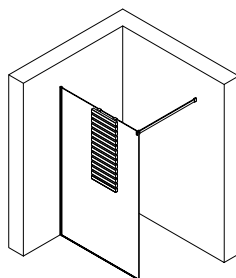

ECLIPSE L - N°1 PZ
50X90 CM

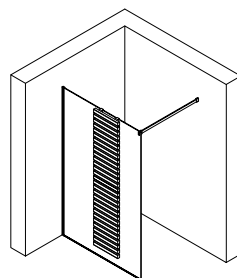

ECLIPSE L - N°2 PZ
50X180 CM

MATERIALI E FINITURE - MATERIALS AND FINISHINGS - MATERIALES Y ACABADOS MATERIAIS E ACABAMENTOS - MATÉRIAUX ET FINITIONS - MATERIAL UND AUSFÜHRUNGEN



Legno Okumè Naturale per applicazione esterna
Natural Okumè wood for external application
Madera natural de Okumè para aplicación externa
Bois d'Okumè naturel pour application externe
Natürliches Okumè-Holz zur äußerlichen Anwendung



Legno Okumè Verniciato adatto all'acqua
Waterproof painted Okumè wood
Madera Okumè pintada impermeableBois
Okumè peint imperméable
Wasserdicht lackiertes Okumè-Holz

OPTIONAL

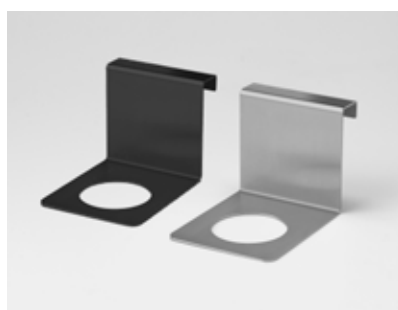
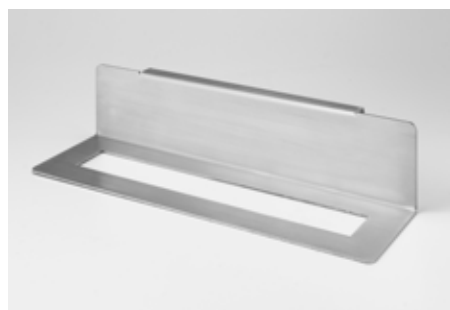



ECLIPSE L - N°1 PZ
50X90 CM



ECLIPSE S - N°1 PZ
30X90 CM



ECLIPSE L - N°2 PZ
50X180 CM



ECLIPSE S - N°2 PZ
30X180 CM







PIATTI DOCCIA
SHOWER TRAYS
PLATOS DE DUCHA
RECEVEURS DE DOUCHE
DUSCHWANNEN



Dai un tocco di stile al tuo bagno
Give a touch of style to your bathroom
¡Agrega un toque de estilo a tu baño
Ajoutez une touche de style à votre salle de bain
Verleihen Sie Ihrem Badezimmer

TECHNART

Piatto doccia - Shower tray

Plato de ducha - Receveur réalisé - Duschtasse

MATERIALI E FINITURE / MATERIALS AND FINISHINGS / MATERIALES Y ACABADOS / MATÉRIAUX ET FINITIONS / MATERIAL UND AUSFÜHRUNGEN

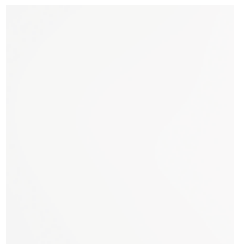

White
B

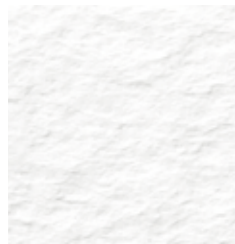

Pietra White
Z

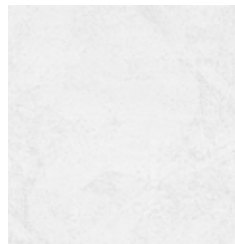

Cemento Concrete White
L

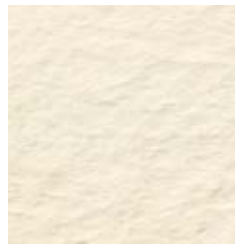

Pietra Tortora
U



Pietra Cappuccino
E



Pietra Fumo
H

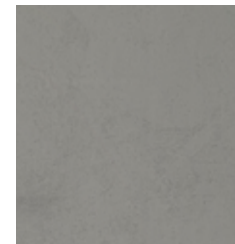

Cemento Concrete Fumo
Q

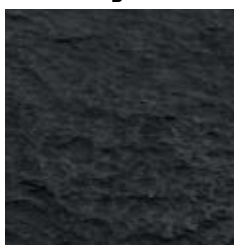

Pietra Karbon
J



Resistente agli urti
Resistant to shocks
Resistente a los golpes
Résistant aux chocs
Stoßfest



Antiscivolo
Non-slip
Antideslizante
Antidérapant
Rutschhemmend



Antibatterico
Antibacterial
Antibacteriano
Antibactérien
Antibakteriell



Resistente agli sbalzi termici
Resistant to thermal changes
Resistente a los cambios térmicos
Résistant aux variations thermiques
Temperaturwechselbeständig



Resistente alle macchie
Resistant to stains
Resistente a las manchas
Résistant aux tâches
Schmutzabweisend



Su misura
Customized
Personalizado
Sur mesure
Personalisiert



Resistente ai raggi UV
Resistant to UV rays
Resistente a los rayos UV
Résistant aux rayons UV
UV beständig

MODELLI / MODELS / MODELOS / MODÈLES / MODELLE

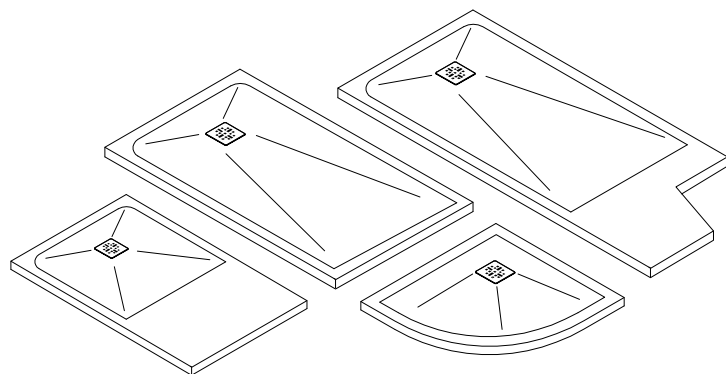

PLANUS

Piatto doccia - Shower tray

Plato de ducha - Receveur réalisé - Duschtasse

MATERIALI E FINITURE / MATERIALS AND FINISHINGS / MATERIALES Y ACABADOS / MATÉRIAUX ET FINITIONS / MATERIAL UND AUSFÜHRUNGEN

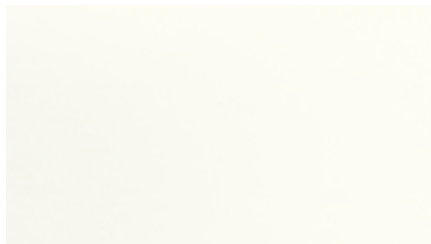

Bianco White - B



Sahara - S



Creta - C

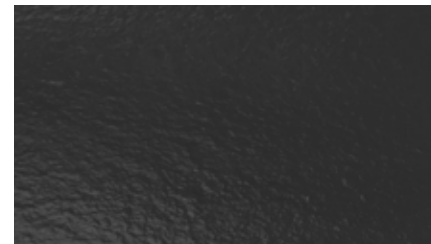

Antracite Black - A



Resistente agli urti
Resistant to shocks
Resistente a los golpes
Résistant aux chocs
Stoßfest



Resistente alle macchie
Resistant to stains
Resistente a las manchas
Résistant aux tâches
Schmutzabweisend



Resistente agli sbalzi termici
Resistant to thermal changes
Resistente a los cambios térmicos
Résistant aux variations thermiques
Temperaturwechselbeständig



Antibatterico
Antibacterial
Antibacteriano
Antibactérien
Antibakteriell



Resistente ai raggi UV
Resistant to UV rays
Resistente a los rayos UV
Résistant aux rayons UV
UV beständig



Antiscivolo
Non-slip
Antideslizante
Antidérapant
Rutschhemmend

CORIAN®

Piatto doccia Corian® - Shower tray Corian®
Plato Corian® - Receveur réalisé Corian® - Duschtasse

MATERIALI E FINITURE / MATERIALS AND FINISHINGS / MATERIALES Y ACABADOS / MATÉRIAUX ET FINITIONS / MATERIAL UND AUSFÜHRUNGEN

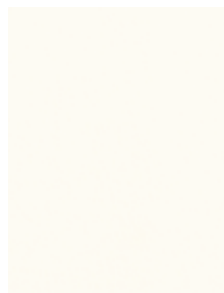

Corian® Glacier White
I



Corian® Nimbus Prima
N



Corian® Raffia
R



Corian® Neutral Concrete
U



Corian® Sienna Brown
B



Corian® Carbon Concrete
K



Corian® Cosmo Prima
P



Resistente agli urti
Resistant to shocks
Resistente a los golpes
Résistant aux chocs
Stoßfest



Resistente alle macchie
Resistant to stains
Resistente a las manchas
Résistant aux tâches
Schmutzabweisend



Resistente agli sbalzi termici
Resistant to thermal changes
Resistente a los cambios térmicos
Résistant aux variations thermiques
Temperaturwechselbeständig



Antibatterico
Antibacterial
Antibacteriano
Antibactérien
Antibakteriell



Resistente ai raggi UV
Resistant to UV rays
Resistente a los rayos UV
Résistant aux rayons UV
UV beständig



Antiscivolo
Non-slip
Antideslizante
Antidérapant
Rutschhemmend

MODELLI / MODELS / MODELOS / MODÈLES / MODELLE

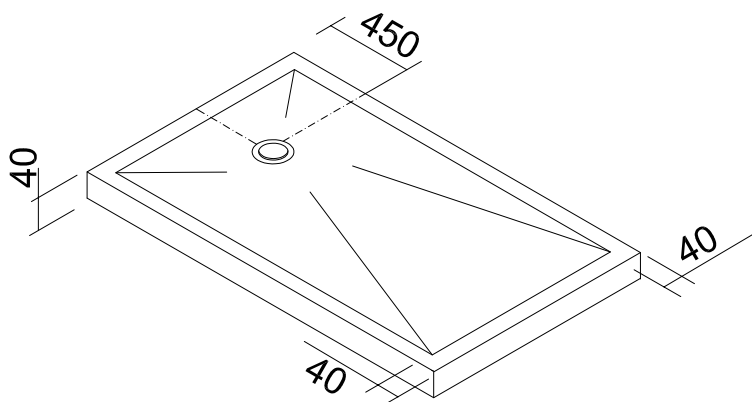





PLANUS





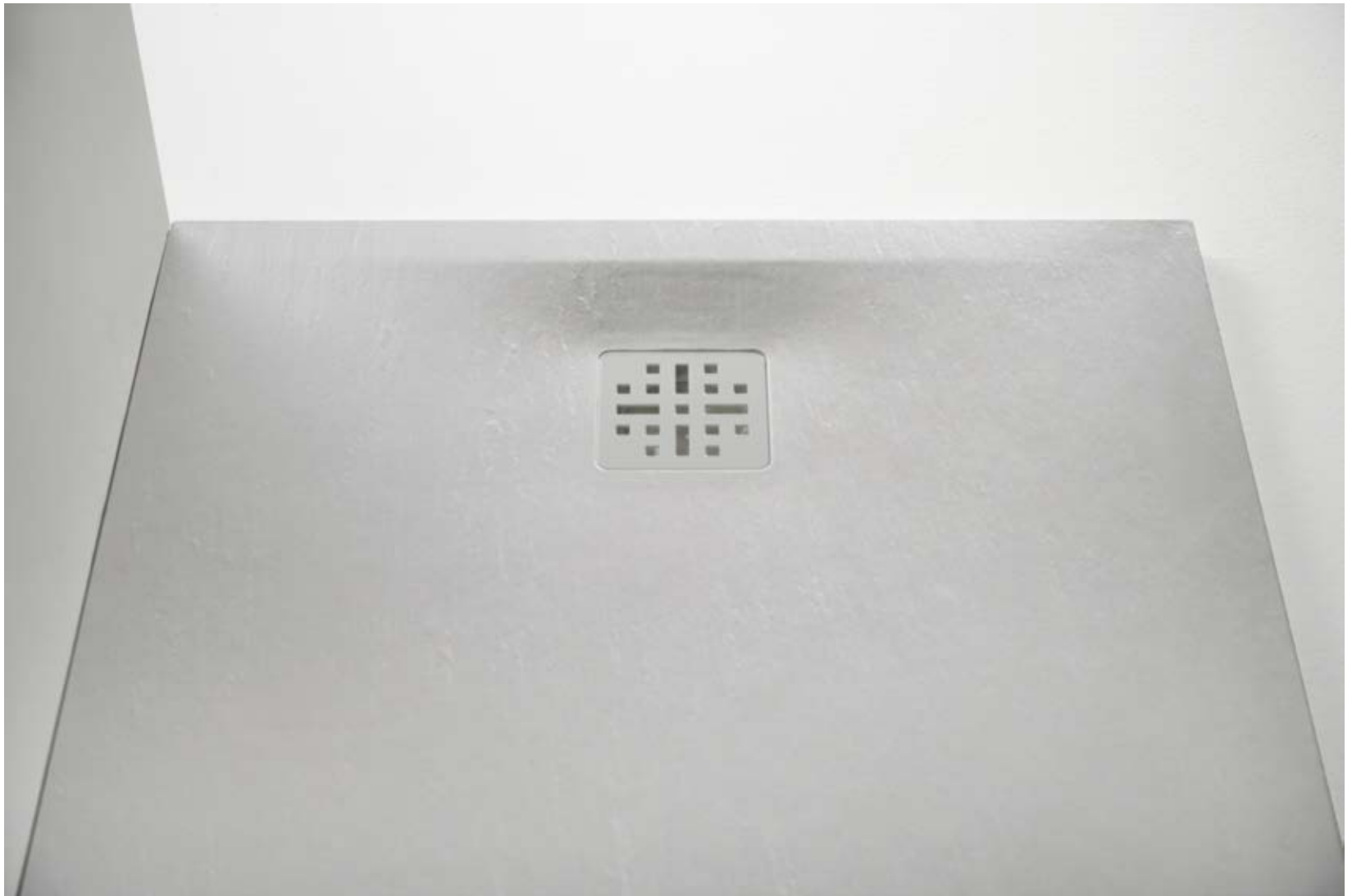



DOISERIE



Nuovo sistema di arredo doccia di Megius, che si compone di pannelli e piatti doccia coordinati realizzati in Corian®

New shower furniture system by Megius, which consists of coordinated shower panels and trays made of Corian®

Nuevo sistema de mueble de ducha de Megius, compuesto por paneles de ducha y platos coordinados de Corian®

Nouveau système de meubles de douche de Megius, composé de panneaux de douche et de receveurs coordonnés en Corian®

Neues Duscharmöbelsystem von Megius, bestehend aus aufeinander abgestimmten Duschpaneelen und Wannen aus Corian®

corian®

MODELLI / MODELS / MODELOS / MODÈLES / MODELLE

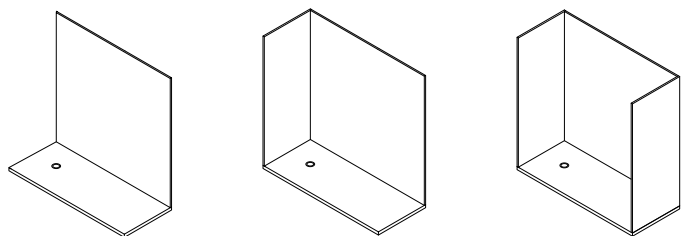

MATERIALI E FINITURE / MATERIALS AND FINISHINGS / MATERIALES Y ACABADOS / MATÉRIAUX ET FINITIONS / MATERIAL UND AUSFÜHRUNGEN

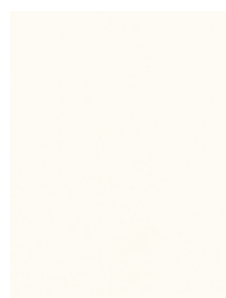

Corian® Glacier White
I



Corian® Nimbus Prima
N



Corian® Raffia
R



Corian® Neutral Concrete
U



Corian® Sienna Brown
B



Corian® Carbon Concrete
K



Corian® Cosmo Prima
P

smart SP1

MODELLI / MODELS / MODELOS / MODÈLES / MODELLE

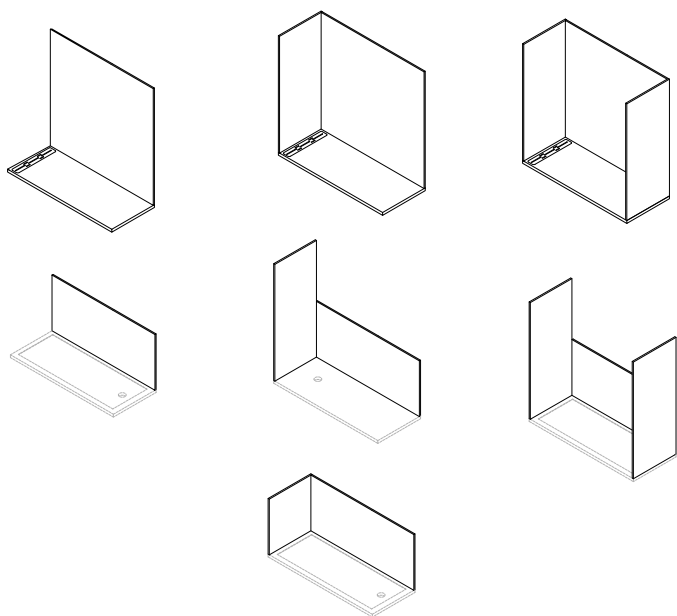



Facilmente lavorabile sul posto
Easy to work on site
Fácilmente laborable en el lugar
Facile à travailler sur place
Einfach arbeiten vor Ort



Personalizzazione estrema
Extreme Customization
Personalización extrema
Personnalisation Extreme
Extreme Anpassbarkeit



Tecnica di incollaggio all'avanguardia
Advanced bonding technology
Sistemas de unión de última generación
La technologie de liaison avancée
Erweiterte Klebtechnik



Facilmente installabile
Easy to install
Fácilmente instalable
Facile à installer
Einfach zu installieren



Piatto e pareti rifiniti su tutti i lati a vista
Plate and walls finished on all sides to view
Placa y paredes acabadas en todos los lados visibles
Plate et les murs finis sur tous les côtés pour voir
Platte und für Wände auf allen Seiten zu betrachten

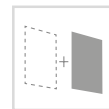

Adattabile a qualsiasi soluzione doccia
Adaptable to any shower solutions
Adaptable a cualquier solución ducha
Adaptable à toutes les solutions de douche
Anpassungsfähig an jede Duschlösungen



Nessuna specializzazione necessaria
in lavori di edilizia avanzati
No expertise required in advanced
construction work
Ninguna especialización necesaria en
trabajos de construcción avanzados
Aucune expertise nécessaire dans les
travaux de construction avancée
Keine Know-how erforderlich in fort-
geschrittenen Bauarbeiten











Un ringraziamento particolare a tutte le persone che ci hanno accolto nelle loro case e nei loro bagni.

A special thanks to all the people who welcomed us into their homes and their bathrooms.

Un merci spécial à tous les gens qui nous ont accueillis dans leurs maisons et leurs salles de bains.

Ein besonderer Dank geht an all die Menschen, die uns in ihren Häusern und in ihren Badezimmern willkommen heißen haben.

Un agradecimiento especial a todas las personas que nos recibieron en sus hogares y baños.

2024