

# WELLNESS BOOK



IT - EN

# WELLNESS BOOK

T I M E L E S S C O L L E C T I O N



Oasi



Karma



Zen Combi Duo Linear



Zen Combi Duo Linear

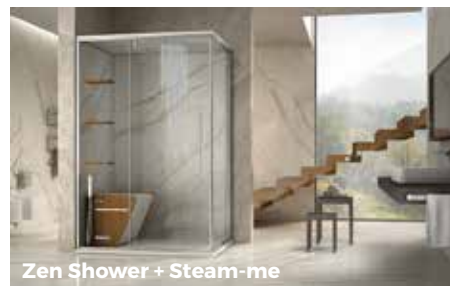

Zen Shower + Steam-me



Zen Shower



Steam-me Soft



Steam-me HPL



Steam-Quadro

 **megius**<sup>®</sup>

SHOWROOM: MILANO - Via Solferino, 36 (Italy) - MESTRINO - Via Torino, 18 PADOVA (Italy)

Megius S.p.A.

Via Torino 18, 35035 Mestrino (PD)

T. +39 049 9048711

[megius@megius.com](mailto:megius@megius.com)

Megius France sarl

106, Rue Des Gémeaux 94613 - Rungis Cedex

T. +33 01 45604225

[megiusfrance@megius.com](mailto:megiusfrance@megius.com)

Megius España S.L.

Diputació, 301 Principal 1ª Barcelona - 08009

T. +34 937 197 536

[megiusespana@megius.com](mailto:megiusespana@megius.com)

Megius Portugal

AP 110, 4745-312

Muro - Trofa - Portugal



[www.facebook.com/megius](https://www.facebook.com/megius)



[www.youtube.com/megius](https://www.youtube.com/megius)



[www.linkedin.com/megius](https://www.linkedin.com/megius)



[www.instagram.com/megius](https://www.instagram.com/megius)



[www.issuu.com/megius](https://www.issuu.com/megius)



# index

---

## 01 SAUNA OUTDOOR:

Oasi Outdoor 19

## 02 SAUNE:

Karma Sauna 37

Tao Sauna 49

Exen Sauna sliding 63

Exen Sauna pivot 81

Nirvana Sauna 93

## 03 SAUNE & HAMMAM:

Nirvana Combi 1 113

Nirvana Combi 1 Young 129

Zen Combi Duo Corner 141

Zen Combi Duo Linear 151

## 04 HAMMAM:

### Prodotti completi: / Complete products:

Wellbox 165

Zen Nude / Shower 187

Zen Idro / Hammam 197

### Generatori di vapore: / Steam Generator:

Steam-Me 219

Steam-Quadro 241

Steam-Mistery Serie 249

### Hammam su misura: / Tailor-made hammam:

Wellzone 255

## 05 DOCCE INTEGRATE /

### INTEGRATED SHOWER ENCLOSURES:

#### Prodotti completi: / Complete products:

Rasodoccia 265

Filodoccia 279

#### Soffioni: / Head showers:

Aqua Genesi 291

Bucket Shower 303





ACQUA | CALORE | COLORE | EMOZIONE  
WATER | HEAT | COLOUR | EMOTION

---

Combinando saune, docce e hammam  
ecco che gli elementi diventano progetti:  
home spa, room spa, hotel spa, mini wellness  
center, ogni spazio può essere  
dedicato al proprio relax.  
Buon viaggio!

By combining saunas, showers and hammams,  
the elements become projects: home spa, room  
spa, hotel spa, mini wellness center, every space  
can be dedicated to your relaxation.  
Enjoy your trip!



SPAART by Megius spa è il progetto dedicato ad architetti, interior designer, progettisti che vogliono spingersi nelle sfide più impervie della progettazione wellness attraverso il design.

SPAART by Megius spa is the project dedicated to architects, interior designers, and planners who want to push themselves into the most difficult challenges of wellness planning through design.



# BENEFICI SAUNA FINLANDESE

## FINNISH SAUNA BENEFITS

Quali sono i benefici che può avere sul nostro fisico la sauna?

Have you ever wondered what benefits the sauna can have on your body?

Vi sveliamo i 3 benefici:

Here are 3 benefits:



### Depura l'organismo

Il sudore che si produce durante una sauna (secca o umida) aiuta a eliminare le tossine dall'organismo, migliorando anche le funzioni immunitarie.

### Purifies the body

The sweat produced during a sauna (dry or wet) helps eliminate toxins from the body, which also improves immune function.



### Smaltisce l'acido lattico e rilassa i muscoli

La sauna rilassa i muscoli, meglio di un semplice bagno caldo o una doccia. Dopo un allenamento ad esempio, la sauna è molto indicata dal momento che aiuta ad alleviare i microstrappi delle cellule muscolari e a smaltire prima l'acido lattico, grazie alla sudorazione e la dilatazione dei vasi sanguigni.

### Eliminates lactic acid and relaxes the muscles

Saunaing relaxes the muscles better than a simple hot bath or shower. After a workout, for example, the sauna is very suitable, since it helps to relieve micro-tears in the muscle cells and to dispose of lactic acid sooner, thanks to sweating and the dilation of blood vessels.



### Elimina lo stress e insonnia

I benefici della sauna non sono soltanto fisici, ma anche psicologici. La sudorazione e il rilassamento non eliminano soltanto tossine e contratture, ma anche l'ansia. I livelli di stress diminuiscono, grazie anche ai tempi rallentati imposti dal trattamento. Si comincia a dormire meglio e se ne risente positivamente anche durante il giorno.

### Eliminates stress and insomnia

The benefits of the sauna are not only physical but also psychological. Sweating and relaxation not only eliminate toxins and tension, but also anxiety. Stress levels decrease, thanks also to the slower pace of the treatment. You begin to sleep better and are also positively affected during the day.



# BENEFICI BIO-SAUNA

## BIO-SAUNA BENEFITS

La biosauna è una sauna intermedia tra calore e vapore che regala una sensazione avvolgente di calore.

Le principali differenze fra sauna e biosauna sono 2: nella biosauna la temperatura non va mai oltre i 60°. L'umidità relativa della biosauna si attesta intorno al 60%. Per ottenere queste condizioni ambientali, al suo interno sono posizionate speciali stufe con dei generatori di vapore integrati.

Anche in questo caso i vasi sanguigni si dilatano, i pori della pelle eliminano tossine attraverso il sudore, ed il nostro corpo (in realtà anche la nostra mente) si rilassa, ma tutto avviene in maniera estremamente più graduale e confortevole, in un lasso di tempo più lungo (la temperatura più mite ci permette di protrarre il trattamento anche per mezz'ora).

Un'altro particolare che differenzia la sauna classica dalla biosauna, è che in quest'ultima vengono diffusi nell'aria oli essenziali provenienti da erbe essiccate e fieno, che penetrano nell'epidermide rivitalizzandola, oltre ad indurre un senso di profondo benessere.

Ora che le differenze le conosci tutte, sta a te decidere se optare per una classica sauna finlandese o per la sua omologa più "soft", che sta prendendo sempre più piede nei moderni centri benessere.

The bio-sauna can be defined as a softer sauna, a kind of middle ground between the sauna and the Turkish bath.

The main differences between the sauna and the bio-sauna are 2: in the bio sauna, the temperature never exceeds 60°C. The relative humidity in the bio sauna is around 60%. To achieve these environmental conditions, special heaters with generators are placed inside the sauna with integrated steam generators.

Again, the blood vessels dilate, the pores of the skin eliminate toxins through sweat, and our body (and our mind) relaxes, but everything happens more gradually and comfortably over a longer period (the milder temperature allows us to continue the treatment for up to half an hour).

Another detail that differentiates the classic sauna from the bio-sauna is that in the bio-sauna essential oils from dried herbs and hay are diffused into the air, which penetrates the skin and revitalizes it, as well as inducing a sense of profound well-being.

Now that you know all the differences, it's up to you to decide whether to opt for a classic Finnish sauna or its softer counterpart, which is becoming increasingly popular in modern wellness centers.



# BENEFICI HAMMAM

## HAMMAM BENEFITS

Il rituale dell'hammam o bagno turco, dovrebbe diventare un'abitudine quotidiana irrinunciabile perché consente di fermarsi, prendersi cura del proprio corpo, della mente e offre svariati benefici come:

- La dilatazione dei vasi sanguigni, in modo da favorire la circolazione
  - Stimola una pulizia profonda della pelle attraverso l'eliminazione delle cellule morte e delle tossine
  - Ha un effetto rilassante e tonificante, aiutando il sistema nervoso a combattere lo stress e la tensione quotidiana
    - Con l'aumento della sudorazione, l'epidermide appare più luminosa, morbida ed elastica

### A chi è consigliato quindi l'hammam?

Non ha nessun tipo di controindicazione, infatti potrebbe essere fatto anche dai bambini sopra i 5 anni e le persone anziane sono incluse, facendo particolare attenzione ai soggetti cardiopatici, diabetici, con infiammazioni dell'epidermide e i portatori di pace-maker.

Come avete potuto leggere l'hammam è consigliato a tutti, per favorire una corretta circolazione sanguigna all'interno del bagno turco è preferibile stare sdraiati o tenere le gambe più in alto rispetto al busto; non mangiate prima di entrare e reintegrare sempre i liquidi una volta fuoriusciti.

The ritual of the hammam or Turkish bath should become an essential daily habit because it allows you to stop and take care of your body and mind and offers various benefits such as:

- The dilation of blood vessels, to promote circulation
- Stimulates deep cleansing of the skin by eliminating dead cells and toxins
- It has a relaxing and invigorating effect, helping the nervous system to fight daily stress and tension
- As perspiration increases, the skin appears brighter, softer, and more elastic.

### Who is the hammam recommended for?

There are no contraindications of any kind it can also be done by children over 5 years old and the elderly are included, paying particular attention to heart patients, diabetics, those with inflammation of the epidermis, and those with pacemakers.

As you have read the hammam is recommended for everyone, to promote proper blood circulation in the Turkish bath is preferable to lie down or keep your legs higher than the bust, do not eat before entering, and always replenish the fluids once out.



# BENEFICI DOCCIA

## SHOWER BENEFIT

### Meglio fare la doccia fredda o calda?

Al giorno d'oggi la doccia viene vista non solo come uno strumento da utilizzare per una veloce e corretta igiene del corpo, ma come un vero momento di relax e benessere sia fisico che mentale per lasciarsi abbandonare a un po' di quiete dopo una giornata stressante. Resta ancora un dubbio però, meglio fare la doccia fredda o calda?

Senza dubbio ci sono due scuole di pensiero ma su un punto si trovano in comune: sotto la doccia vengono le idee migliori, d'inverno accompagnate dall'acqua calda mentre d'estate si predilige quella fredda; vediamo insieme quali sono i benefici di entrambe:

#### DOCCIA FREDDA

- Agisce sul metabolismo
- Rafforza il sistema immunitario
- Migliora la circolazione sanguigna
- Regola la temperatura interna e rigenera il corpo
- Ha un effetto tightening sulla pelle, cioè la rende più compatta e con un effetto lifting naturale
  - Allevia la pressione
- Migliora il movimento linfatico
- Aumenta i livelli di energia e benessere

#### DOCCIA CALDA

- Purifica la pelle e apre i pori
- Riduce le tensioni muscolari, dovute a contratture o dolori cervicali
- Ricarica le batterie e dà nuove energie
- È ottimale per il raffreddore, grazie al vapore generato dal calore, riduce la congestione nasale
- Ci si può godere la doccia con più calma e aiuta a combattere la depressione

### Is it better to take a cold or hot shower?

Nowadays the shower is seen not only as a tool to be used for quick and proper body hygiene but as a real moment of relaxation and well-being, both physical and mental, to indulge in a little quiet after a stressful day. The question remains, however, whether it is better to take a cold or hot shower.

There are undoubtedly two schools of thought, but on one point they are in common: the best ideas come from the shower, in winter accompanied by hot water while in summer cold water is preferred; let's see together what the benefits of both are:

#### HOT SHOWER

- Purifies the skin and opens the pores
  - Reduces muscle tension due to contractures or neck pain
  - Recharges the batteries and gives new energy
- Optimal for colds, thanks to the steam generated by the heat, reducing nasal congestion
  - You can enjoy your shower more calmly and it helps fight depression

#### COLD SHOWER

- Acts on the metabolism
- Strengthens the immune system
- Improves blood circulation
- Regulates internal temperature and regenerates the body
- It has a tightening effect on the skin, i.e. it makes the skin firmer and with a natural lifting effect
  - Relieves pressure
- Improves lymphatic movement
- Increases energy levels and well-being

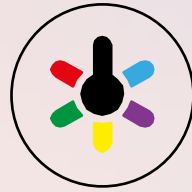

# BENEFICI CROMOTERAPIA

## CHROMOTHERAPY BENEFITS

La Cromoterapia è una medicina alternativa antica che la civiltà occidentale ha riscoperto in tempi recenti, si basa sulla codificazione di 12 colori che rappresentano le diverse parti del corpo umano. I colori infatti, vengono utilizzati per influenzare la mente e il corpo della persona, al fine di aiutarla a ritrovare un equilibrio funzionale e una sensazione generale di benessere fisico e psicologico.

La cromoterapia con onde elettromagnetiche è l'utilizzazione della luce colorata che, all'interno di una precisa lunghezza d'onda, penetra nei tessuti creando le condizioni di interagire con le cellule ripristinando l'equilibrio elettrico e chimico dell'omeostasi cellulare migliorandone le funzioni biologiche.

Chromotherapy is an ancient alternative medicine that western civilization has rediscovered in recent times. It is based on the codification of 12 colors that represent the different parts of the human body; colors are used to influence a person's mind and body to help them regain a functional balance and a general feeling of physical and psychological wellbeing.

Chromotherapy with electromagnetic waves is the use of colored light which, within a precise wavelength, penetrates into the tissues creating the conditions to interact with the cells, restoring the electrical and chemical balance of cellular homeostasis, and improving biological functions.



**MATERIOTECA**

# FINITURE LEGNO

## WOOD FINISHES

### HEMLOCK



LEGNO HEMLOCK, è una conifera canadese. Legno resistente e contraddistinto dal colore caldo e dalla tessitura uniforme. Hemlock è un legno molto adoperato come legname da costruzione e come rivestimenti in genere, infatti viene utilizzato sia per l'interno che per l'esterno delle saune, ed è presente sia nella versione impiallacciata che dogata.

HEMLOCK WOOD is a Canadian softwood. It is a durable wood with a warm color and uniform texture. Hemlock is a wood widely used as construction timber and as cladding in general, in fact, it is used both for the interior and exterior of saunas and is available in both veneered and staved versions.

### CEDRO CEDAR



LEGNO di CEDRO, è ideale per le saune su misura perché dona eleganza visiva attraverso i listelli che vengono applicati manualmente. La particolarità di questo tipo di legno è data dalla sua naturale aromaticità che esaltata dal calore della sauna, rilascia costantemente una fragranza intensa.

CEDAR WOOD is ideal for custom-made saunas because it gives visual elegance through the strips that are applied by hand. The particularity of this type of wood is its natural aromaticity, which, enhanced by the heat of the sauna, constantly releases an intense fragrance.

### ABETE CLASSIC LISCIO E DOGATO FIR CLASSIC SMOOTH AND STAVED



LEGNO ABETE, di tradizione nordica con il colore marrone chiaro e la presenza di nodi a vista che donano un'atmosfera calda e accogliente. Tra le caratteristiche del legno di abete spicca la sua capacità di trattenere il calore e ha ottime capacità isolanti, perché poco sensibile agli sbalzi termici. Per questo motivo può essere usato sia in zone fredde che calde e viene utilizzato sia per l'interno che per l'esterno delle saune, ed è presente sia nella versione impiallacciata che dogata.

FIR WOOD, from the Nordic tradition with its light brown color and the presence of visible knots that give a warm and cozy atmosphere. One of the characteristics of fir wood is its ability to retain heat and it has excellent insulating properties, as it is not very sensitive to temperature changes. For this reason, it can be used in both cold and warm areas and is used both inside and outside saunas, and is available in both veneered and slatted versions.

### AYOUS



Il LEGNO DI AYOUS deriva dalle foreste dell'Africa equatoriale occidentale. A volte è chiamato anche "obeche". È un legno di colore giallognolo chiaro, tenero e leggero senza venature. Per la sua resistenza al calore e all'umidità, la sua leggerezza e l'assenza di nodi, il legno di ayous è utilizzato per la costruzione di saune.

Ayous wood comes from the forests of western equatorial Africa. It is sometimes also called 'obeche'. It is a light yellowish wood, soft and light without veins. Due to its resistance to heat and humidity, its lightness and its lack of knots, Ayous wood is used for sauna construction.

### TIGLIO LINDEN



È un legno chiaro, molto morbido al tatto e con venature sottili e uniformi, particolarmente apprezzato per l'utilizzo in saune grazie alla sua scarsa conducibilità termica: non si surriscalda al contatto, rendendolo ideale per panche e schienali. Inoltre, è privo di resina e nodi, qualità che lo rendono esteticamente pulito e confortevole. È adatto a chi cerca un ambiente visivamente delicato e accogliente.

It is a light wood, very soft to the touch, with fine, uniform grains, particularly appreciated for use in saunas due to its low thermal conductivity: it does not overheat upon contact, making it ideal for benches and backrests. Additionally, it is free of resin and knots, making it aesthetically clean and comfortable. It is suitable for those seeking a visually delicate and welcoming environment.

### TEAK



Il legno di Teak viene ricavato dalla pianta della Tectona, reperibile in Africa e Asia. Il Teak è un'essenza pregiata, rinomata sia per le sue caratteristiche: idrorepellenza, resistenza a salsedine e agenti atmosferici. Si presta, per questi motivi, a un'ampia varietà di utilizzi, infatti grazie sue proprietà e all'eccezionale resistenza, questo tipo di legno è ideale anche in ambienti interni umidi come la stanza da bagno o per le saune: il suo contenuto di resina oleosa lo rende resistente all'acqua e alle escursioni termiche.

Teak wood is obtained from the Tectona plant, found in Africa and Asia. Teak is a precious wood, renowned for its characteristics: water repellence, resistance to saltiness and atmospheric agents. For these reasons, it lends itself to a wide variety of uses. Thanks to its properties and exceptional resistance, this type of wood is also ideal for humid indoor environments such as bathrooms or saunas: its oily resin content makes it resistant to water and temperature changes.

**OLMO**  
**ELM**



Con la sua tonalità calda e la venatura marcata, si distingue per la sua resistenza all'umidità ed è spesso utilizzato in ambienti umidi.

With its warm tone and marked grain, oak is distinguished by its resistance to moisture and is often used in humid environments.

**ROVERE**  
**OAK**



Estremamente resistente e durevole, il rovere è uno dei legni più apprezzati in ambito wellness per la sua robustezza naturale e la capacità di mantenere intatta la sua bellezza nel tempo. Con le sue venature marcate e il tono caldo, è perfetto per pavimenti, rivestimenti e dettagli decorativi in spa di alto livello. Il suo aspetto imponente e la consistenza compatta lo rendono ideale per creare un'atmosfera di eleganza solida e naturale. Sebbene sopporti bene l'umidità, viene utilizzato con più frequenza in zone a contatto moderato con calore e vapore.

Extremely strong and durable, oak is one of the most appreciated woods in wellness settings for its natural sturdiness and ability to maintain its beauty over time. With its pronounced grain and warm tone, it is perfect for flooring, cladding, and decorative details in high-end spas. Its imposing appearance and compact texture make it ideal for creating an atmosphere of solid and natural elegance. Although it handles humidity well, it is more frequently used in areas with moderate exposure to heat and steam.

**IROKO**



L'iroko è un legno proveniente dalle foreste dell'Africa, di colore scuro che tende a scurirsi nel tempo. E' un legno facile da lavorare nonostante la sua durezza, durevole nel tempo e particolarmente stabile, poco sensibile alle variazioni del tasso di umidità e della temperatura, ideale per le saune.

Iroko is a wood from the forests of Africa, dark in color and tends to darken over time. It is an easy wood to work with, despite its hardness, durable and particularly stable, not sensitive to changes in humidity and temperature, ideal for saunas.

**OKUMÈ**



Il legno Okumè (o Okoumé) è considerato come il legno più idrorepellente in assoluto. L'Okumè è molto apprezzato per le sue doti di durabilità negli anni anche se esposto a fattori naturali. La sua trama lo rende un materiale apprezzato sia in versioni tinte che in laccatura con discreti risultati di finitura ed eleganza. Buona è la resa termica data la bassa densità, ideale per la costruzione delle saune.

Okumè (or Okoumé) wood is considered to be the most water-repellent wood of all. Okumè is highly valued for its durability over the years, even when exposed to natural factors. Its texture makes it an appreciated material in both stained and lacquered versions with discrete results in terms of finish and elegance. It has a good thermal performance due to its low density, making it ideal for sauna construction.

**NOCE CANALETTO**  
**CANALETTO WALNUT**



Pregiato e raffinato, il noce canaletto si distingue per le sue venature eleganti e il tono naturalmente scuro, capace di donare un tocco di lusso e calore agli ambienti wellness. Utilizzato principalmente per dettagli decorativi, arredi su misura e rivestimenti di pregio, è ideale per chi desidera un'estetica sofisticata. Tuttavia, essendo meno resistente all'umidità rispetto ad altri legni, non è consigliato per zone a diretto contatto con calore intenso o vapore, come saune o hammam.

Precious and refined, canaletto walnut stands out for its elegant grain and naturally dark tone, adding a touch of luxury and warmth to wellness spaces. Mainly used for custom-made furnishings, decorative details, and high-end cladding, it is ideal for those seeking a sophisticated aesthetic. However, as it is less resistant to moisture compared to other woods, it is not recommended for areas in direct contact with intense heat or steam, such as saunas or hammams.

**FRASSINO TERMOTRATTATO**  
**THERMO-TREATED ASH**



Sottoposto a un particolare processo che ne migliora la stabilità, assume una tonalità più scura. Ottenuto attraverso un processo di trattamento termico che ne modifica la struttura interna, il frassino termotrattato acquista una maggiore stabilità dimensionale e una resistenza superiore a umidità e calore. Questo trattamento dona al legno una tonalità più scura e intensa, rendendolo molto apprezzato per ambienti wellness contemporanei. Viene spesso impiegato per rivestimenti interni di saune, spa e zone relax, dove si cerca un equilibrio tra eleganza naturale e performance tecnica. Il suo aspetto caldo e la texture marcata creano un ambiente accogliente e sofisticato.

Subjected to a special process that enhances its stability, it takes on a darker tone. Through thermal treatment, the wood's internal structure is modified, giving it greater dimensional stability and resistance to moisture and heat. This process gives the wood a deeper, richer tone, making it very popular in contemporary wellness environments. It is often used for internal cladding in saunas, spas, and relaxation areas, where a balance between natural elegance and technical performance is sought. Its warm appearance and pronounced texture create a welcoming and sophisticated atmosphere.

## VERNICIATO NERO BLACK-PAINTED

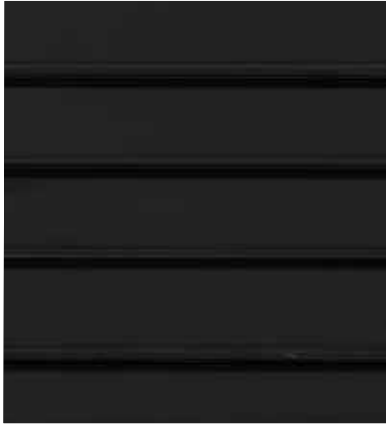

Dal look deciso e contemporaneo, il legno verniciato nero è una scelta stilistica audace che conferisce profondità e raffinatezza agli ambienti wellness. La finitura scura enfatizza le venature naturali del legno e crea contrasti visivi forti, perfetti per spa moderne ed esclusive. Ideale per rivestimenti, arredi di design e dettagli decorativi, offre una buona protezione superficiale contro umidità e usura

With a bold and contemporary look, black painted wood is a stylish choice that adds depth and refinement to wellness environments. The dark finish emphasizes the natural grains of the wood and creates strong visual contrasts, perfect for modern and exclusive spas. Ideal for cladding, designer furniture, and decorative details, it offers good surface protection against moisture and wear.

## ABETE CLASSIC VERNICIATO FIR CLASSIC VARNISHED



Il LEGNO ABETE classic verniciato, è molto utilizzato nel mondo del wellness per le sue ottime capacità isolanti, offre la possibilità di impiegare vernici apposite di base all'acqua di colore bianco o nero che non rilasciano sostanze tossiche ad alte temperature ed è presente per la versione dogata.

Varnished classic fir wood is widely used in the world of wellness for its excellent insulating properties. It offers the possibility of using special white or black water-based varnishes that do not release toxic substances at high temperatures and is available in the slatted version.



## PIETRE PERIDOTICHE PERIDOTITIC STONES

Queste pietre sono comunemente chiamate pietre peridotitiche e derivando dal minerale naturale "peridotite". Si tratta di pietre magmatiche intrusive, molto dure, pesanti e di colore scuro; sono attentamente selezionate secondo le antiche tradizioni Finniche al fine di trasmettere il massimo del calore accumulato in tutte le direzioni.

Lo scopo delle pietre peridotitiche per sauna, è quello d'immagazzinare calore, elevarne la temperatura e rilasciarlo durante tutta la durata della sauna.

Una cosa da non sottovalutare è il corretto posizionamento delle pietre nella stufa:

non devono mai essere ammassate ma si devono disporre in modo di lasciare spazio tra uno strato e l'altro e vanno posizionate all'interno della stufa senza sovraccaricare la stufa stessa.

In una confezione è possibile trovare pietre dalla forma piatta (ideali per la collocazione tra gli elementi delle resistenze) e pietre a sezione maggiorata (da porre nella parte superiore della stufa).

La vita media delle pietre in una stufa elettrica è di circa 2 anni.

These stones are commonly called peridotite stones and are derived from the natural mineral 'peridotite'. They are very hard, heavy, and dark-colored magmatic intrusive stones; they are carefully selected according to ancient Finnish traditions to transmit the maximum amount of stored heat in all directions.

The purpose of sauna stones is to store heat, raise the temperature and release it throughout the sauna.

One thing that should not be underestimated is the correct positioning of the stones in the stove:

They should never be piled up, but should be arranged to leave space between layers, and should be placed inside the stove without overloading the stove.

Flat stones (ideal for placing between the heating elements) and large stones (to be placed in the upper part of the stove) are available in a pack.

The average life of the stones in an electric stove is about 2 years.

## ALTRE FINITURE OTHER FINISHES

### FINITURA GREY STONE GREY STONE FINISH



Foglio di pietra rigida non curvabile, supportato con fibra di vetro scura, di spessore 1,5 mm, adatto per rivestire pareti esterne ed interne, regge agli sbalzi di temperatura e all'azione degli agenti atmosferici.

Rigid, non-curvable stone sheet, supported with dark fibreglass, 1.5 mm thick, suitable for covering external and internal walls, resistant to temperature changes and the action of atmospheric agents.

### LAMIERA VERNICIATA BIANCA WHITE PAINTED SHEET METAL



### LAMIERA VERNICIATA GRIGIO ANTRACITE ANTHRACITE GRAY PAINTED SHEET METAL



### LAMIERA VERNICIATA TESTA DI MORO PAINTED SHEET METAL IN DARK BROWN



### VETRO TEMPERATO IN DIVERSE FINITURE TEMPERED GLASS IN DIFFERENT FINISHES



Per l'ampia gamma di soluzioni doccia, sono disponibili diversi tipi di finiture vetro, in modo da soddisfare le diverse richieste:

dal classico è più richiesto vetro Trasparente, che consente alla luce di passare e di creare un insostituibile articolo di design al vetro Extrachiaro, che si distingue dal trasparente per un'elevata trasparenza e dal colore neutro del bordo.

Per un gioco di "vedo - non vedo" e con un'alta declinazione di design si può invece scegliere la soluzione di vetro Fumè o in alternativa optare per la finitura vetro Opaline, reso traslucido o opaco durante la lavorazione, e può contribuire a donare un tocco di eleganza nell'arredamento del bagno.

Se invece si vuole rendere unico il proprio box doccia, si può scegliere la versione di finitura di vetro retroverniciato con colorazione bianco o nero, dove al vetro liscio viene applicata una retroverniciatura.

I nostri vetri si distinguono per un'ottima trasparenza, eccellente resistenza al graffio, all'abrasione e hanno una buona resistenza al calore.

Un concentrato di tecnologia che rende il vetro un Tecnovetro, secondo la norma UNI EN12600. In base a quanto stabilito da UNI EN14428, il vetro di una doccia dovrebbe essere temprato, quindi con standard definiti di frammentazione. Si tratta di un vetro temperato con uno spessore della membrana di 100 micron che controlla la frammentazione del vetro in caso di rottura, limitando il possibile danno all'ambiente.

For the wide range of shower solutions, different types of glass finishes are available to meet different requirements:

from the classic and most popular Transparent glass, which allows light to pass through and create an irreplaceable design item to Extra Clear glass, which differs from Transparent glass in its high transparency and neutral edge color.

For a game of "I see - I don't see" and with a high declination of design, you can instead choose the Smoked glass solution or opt for the Opaline glass finish, made translucent or opaque during processing, and can help give a touch of elegance to the bathroom decor.

If, on the other hand, you want to make your shower enclosure unique, you can choose the back-painted glass finish version in white or black, where a back-painting is applied to the smooth glass.

Our glass is characterized by excellent transparency, excellent scratch and abrasion resistance, and good heat resistance.

A concentration of technology that makes the glass a Tecnovetro, according to UNI EN12600. According to UNI EN14428, the glass in a shower should be tempered, i.e. with defined fragmentation standards. This is tempered glass with a membrane thickness of 100 microns that controls glass fragmentation in the event of breakage, limiting possible damage to the environment.



## FINITURE PROFILI

### PROFILE FINISHES

I materiali che più vengono utilizzati per i nostri profili sono fatti di Alluminio e d'Acciaio. L'Alluminio è uno degli elementi più diffusi in natura, riutilizzabile e riciclabile, facilmente lavorabile e con un'alta adattabilità del materiale utilizzato mentre l'Acciaio Inox AISI 304 è un materiale facile da pulire, altamente igienico ed ha una forte resistenza alla corrosione. Oltre ad avere aspetti estetici interessanti, eleganti e con linee molto pulite, i profili in acciaio Inox godono di un basso costo di manutenzione, facilità di fabbricazione ed è riciclabile.

The materials most commonly used for our profiles are Aluminium and Steel.

Aluminum is one of the most common elements in nature, reusable and recyclable, easily workable and with high adaptability of the material used, while AISI 304 Stainless Steel is an easy-to-clean material, highly hygienic and has strong corrosion resistance. In addition to having interesting aesthetic aspects, elegant and with very clean lines, stainless steel profiles enjoy low maintenance costs, ease of manufacture and are recyclable.



Bianco  
White



Nero  
Black



Grigio  
Grey

## HPL

È un pannello multistrato composto da: 1 pannello in PVC interno di vario spessore, 2 fogli di alluminio esterni + il pannello di rivestimento in finitura. Disponibile in diverse colorazioni: bianco, antracite, nero, nero marquina e white marble.

HPL is a multilayer panel consisting of 2 outer aluminum sheets with 6mm thick PVC inside, available in different finishes: white, anthracite and black.



White Marble

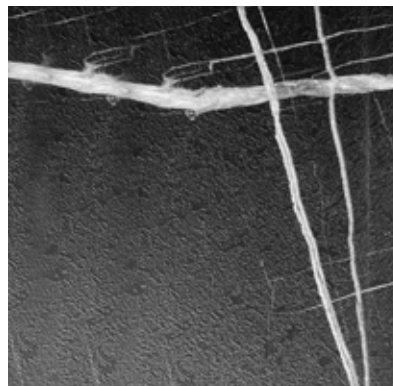

Nero Marquina  
Marquina Black



Soft Anthracite  
Soft Anthracite



Soft Tortora  
Soft Dove Grey



OASI  
SAUNA  
OUTDOOR



Nella Sauna OASI,  
progettata per  
l'esterno, si uniscono  
**resistenza e  
raffinatezza:**

una soluzione che mantiene l'armonia e i profumi distintivi dei prodotti wellness di Megius. Il rivestimento esterno è disponibile in robusta lamiera, ideale per affrontare le intemperie, oppure in legno naturale, perfetto per zone riparate. Internamente, il calore e l'eleganza del legno avvolgono gli ospiti, offrendo un'esperienza autentica e immersiva.

In the OASI  
Sauna, designed  
for outdoor use,  
**resilience meets  
elegance:**

a solution that preserves the harmony and distinctive scents of Megius wellness products. The external cladding is available in durable sheet metal, ideal for withstanding the elements, or in natural wood, perfect for sheltered areas. Inside, the warmth and elegance of wood embrace guests, offering an authentic and immersive experience.









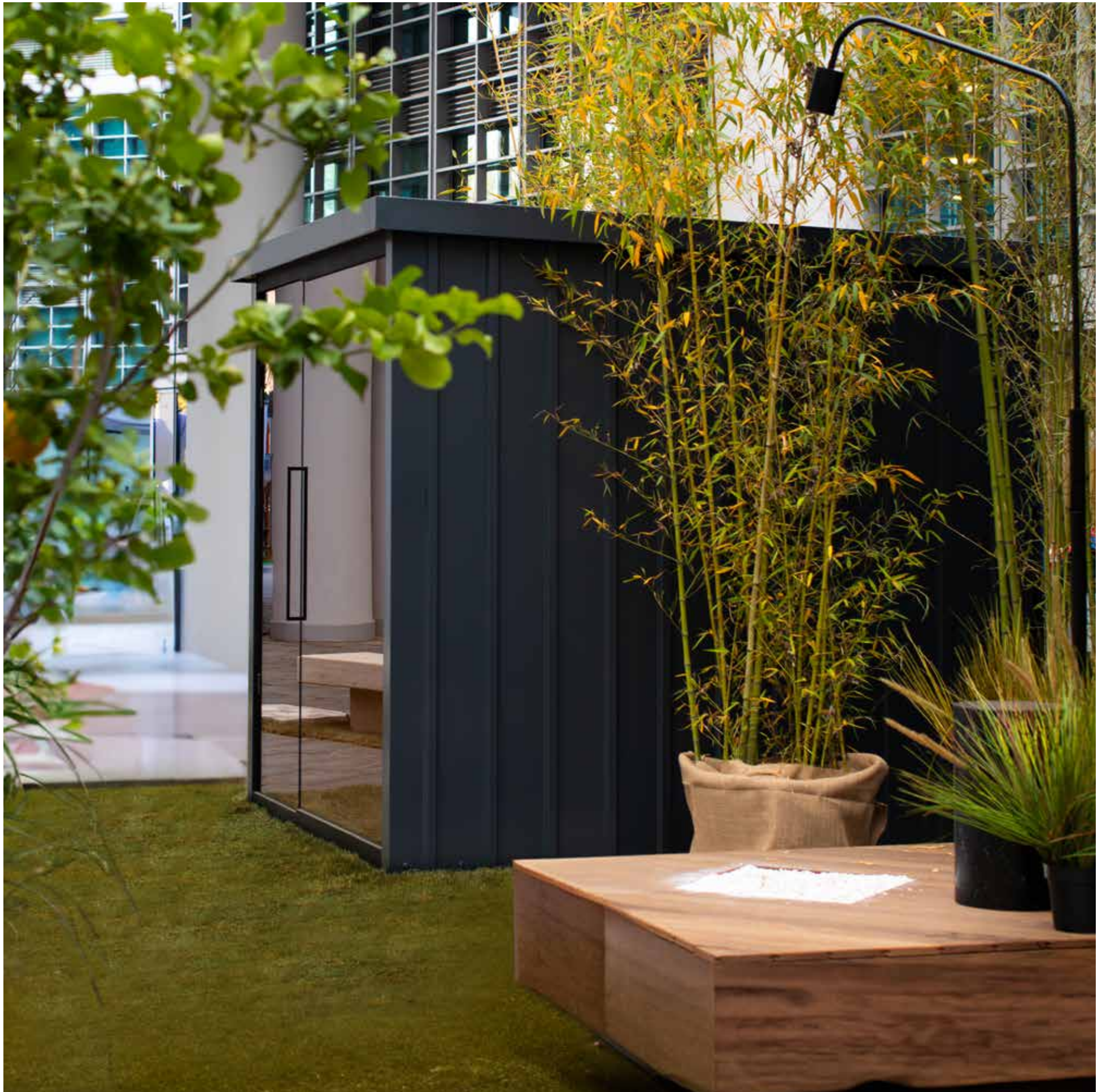

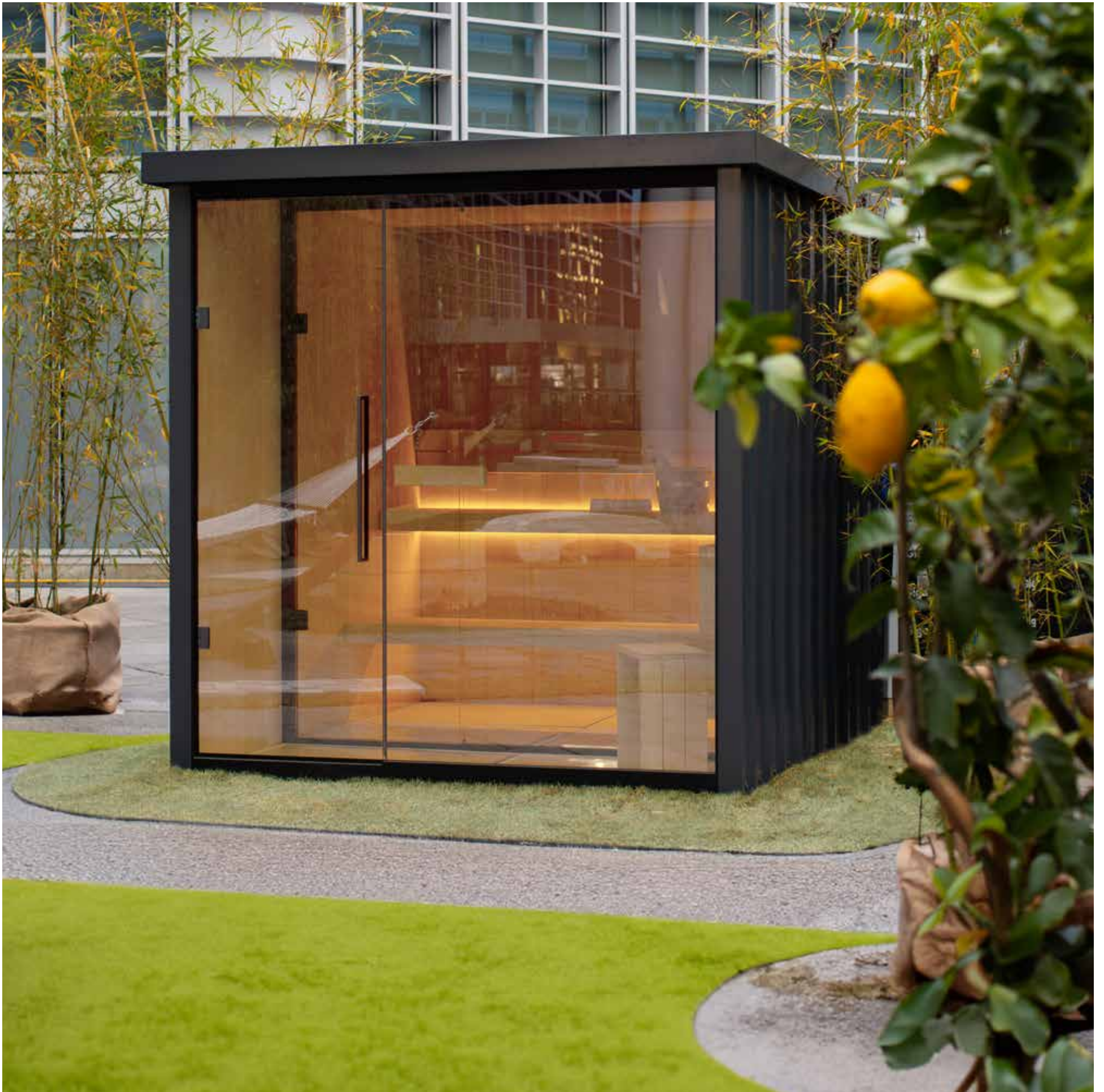





La Sauna OASI si distingue per la sua raffinata finitura esterna disponibile in due eleganti tonalità di legno verniciato: bianco luminoso o nero intenso. Perfetta per spazi esterni riparati, come una terrazza sotto una tettoia o un angolo di giardino protetto, unisce stile e funzionalità. Questi rivestimenti sono progettati per resistere all'esposizione esterna non diretta, garantendo durata nel tempo e un'estetica contemporanea che valorizza ogni ambiente. Una soluzione che sposa armonia e design, ideale per vivere il wellness all'aria aperta.

The OASI Sauna stands out for its refined exterior finish, available in two elegant painted wood tones: bright white or deep black. Perfect for sheltered outdoor spaces, such as a terrace under a canopy or a protected garden corner, it combines style and functionality. These finishes are designed to withstand indirect outdoor exposure, ensuring durability over time and offering a contemporary aesthetic that enhances any setting. A solution that blends harmony and design, ideal for enjoying wellness in the open air.





La sauna da esterno unisce benessere e design in un'unica soluzione elegante e funzionale. Realizzata con materiali di alta qualità e lavorata con maestria artigianale Made in Italy, si distingue per la sua struttura resistente e raffinata, pensata per integrarsi perfettamente in giardini, terrazze o spazi all'aperto protetti. Il legno pregiato, trattato per resistere agli agenti atmosferici, esalta l'estetica naturale, offrendo un ambiente accogliente e immersivo. Una fusione perfetta tra comfort e stile, per vivere l'esperienza della sauna in totale relax, a contatto con la natura.

The outdoor sauna combines wellness and design in a single elegant and functional solution. Crafted with high-quality materials and masterful Italian craftsmanship, it stands out for its durable and refined structure, designed to blend seamlessly into gardens, terraces, or protected outdoor spaces. The premium wood, treated to withstand atmospheric agents, enhances its natural aesthetic, creating a warm and immersive environment. A perfect fusion of comfort and style, allowing you to experience the sauna in total relaxation, surrounded by nature.

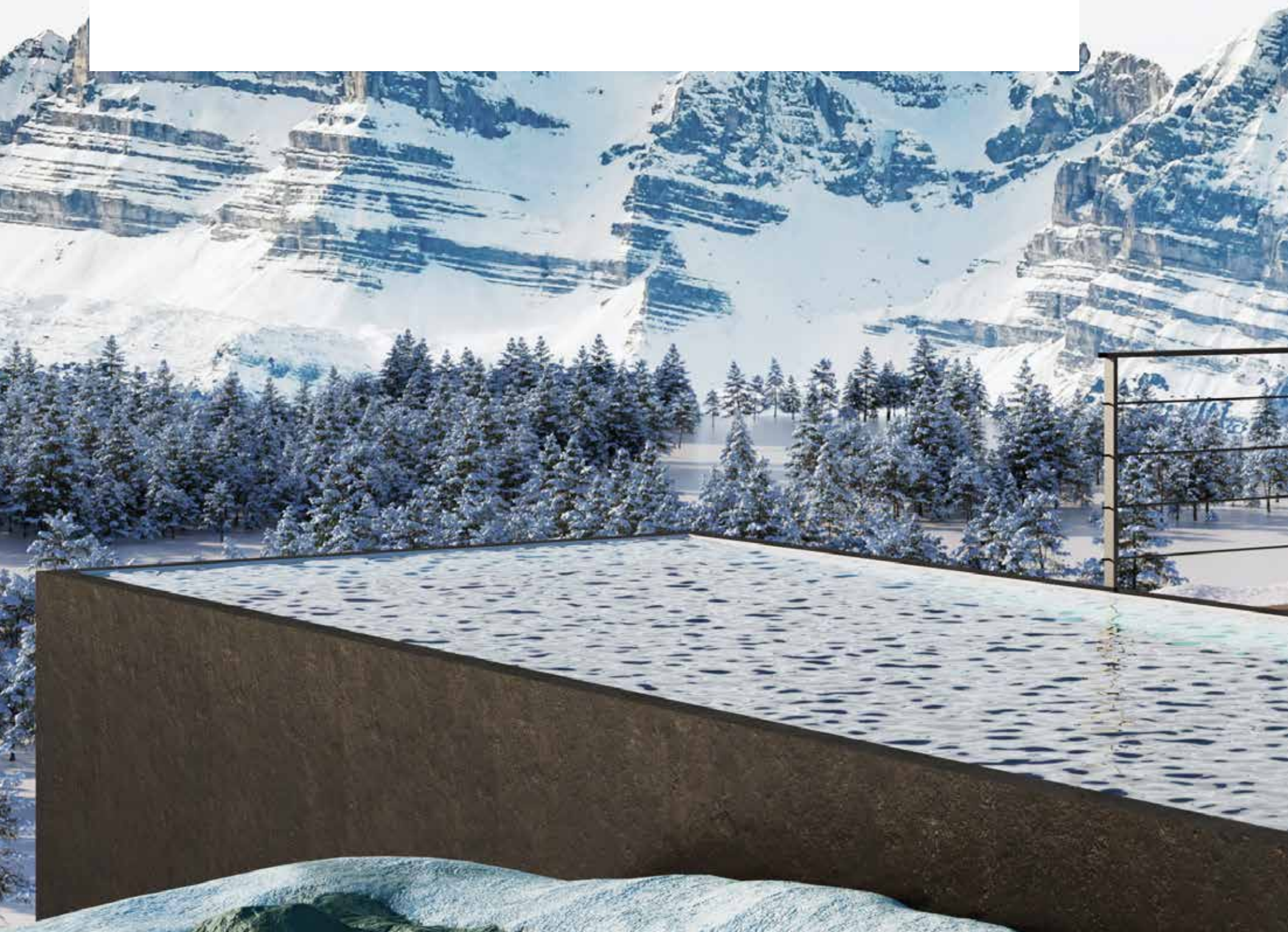





**TERMOIGROMETRO SAUNA**  
SAUNA THERMOHYGROMETER



**MASTELLO E MESTOLO**  
BUCKET AND LADLE



**POGGIATESTA**  
HEADREST



**CLESSIDRA**  
HOURGLASS



**PULSANTE DI ALLARME**  
ALARM BUTTON



**MANIGLIA IN LEGNO INTERNA/ESTERNA**  
WOODEN HANDLE FOR INTERNAL/EXTERNAL USE

## SAUNA FINLANDESE DA ESTERNO

## FINITURE LEGNO INTERNO



Ligno Tiglio "G"

## SEDUTA SAUNA



Ligno Ayous

## FINITURE PROFILI

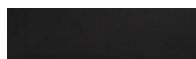

Alluminio Nero "Z"



Alluminio Cromo Brillante "Q"

## RIVESTIMENTO ESTERNO IN LEGNO (ideale per esterni coperti o protetti)

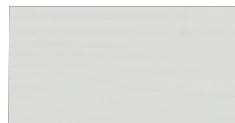

Ligno verniciato Bianco "Y"



Ligno verniciato Nero "W"

## RIVESTIMENTO ESTERNO IN LAMIERA (ideale per esposizione totale agli agenti atmosferici)



Lamiera verniciata bianca "E"



Lamiera verniciata grigio antracite "J"



Lamiera verniciata testa di moro "D"

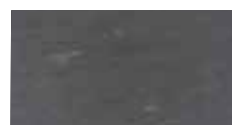

Finitura Grey Stone "P"

## FINITURE VETRO DI CHIUSURA



Vetro Trasparente "P"



Vetro Bronzo "1Z"



Vetro Bronzo satinato "1J"



Vetro Fumè "K"

DIMENSIONI STANDARD	2300x2550 mm
ALTEZZA STANDARD	h. 2200/2290 mm
SPESSORE DEI VETRI	6/8 mm
MANIGLIA	alluminio/legno
DIMENSIONI DELLA MANIGLIA	58 cm
ALIMENTAZIONE ELETTRICA	220-380 kW - specificare prima dell'ordine
NUMERO DI PERSONE MAX.	4 (2300x2550 mm)
MATERIALE PORTA	Vetro temperato
MATERIALE PANCA	Ligno Ayous
ILLUMINAZIONE	led
PROTEZIONE ESTERNA	vernice impermeabile (ver. in legno)
TETTO	OPTIONAL (copertura in lamiera)

## CARATTERISTICHE/COMPONENTI

Touch displayscreen per controllo funzioni  
 Stufa elettrica con pietre laviche  
 Luce a LED retro panca  
 Clessidra con sabbia per durata tempo da 15 minuti.  
 Termoigrometro per controllo temperatura e umidità all'interno della sauna.  
 Mastello e mestolo in legno.  
 Porta sauna in vetro trasparente temperato da 6 mm di spessore  
 Porta spogliatoio in vetro trasparente temperato da 8 mm di spessore (dove presente)  
 Panche in legno Ayous



## PREDISPOSIZIONE COLLEGAMENTO DOMOTICA:

La sauna può essere integrata con sistemi di domotica compatibili, grazie alla scheda elettronica predisposta. Questo permette di gestire l'accensione e lo spegnimento della stufa e dei led direttamente tramite il sistema, offrendo Comfort e praticità avanzati.

## FINNISH OUTDOOR SAUNA

### WOOD FINISHES



Linden Wood "G"

### BENCH FINISHES



Ayous wood

### PROFILE FINISHES



Matt Black Aluminum "Z"



Brilliant Chrome Aluminium "Q"

### EXTERNAL WOOD CLADDING (ideal for covered or sheltered outdoor spaces)

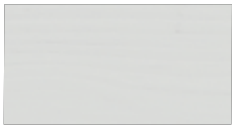

Painted wood White "Y"



Painted wood Black "W"

### EXTERNAL SHEET METAL CLADDING (ideal for total exposure to weather conditions)



White painted sheet metal "E"



Anthracite gray painted sheet metal "J"



Painted sheet metal in dark brown "D"



Grey Stone finish "P"

### GLASS CLOSING FINISHES



Transparent Glass "P"



Bronze Glass "1Z"



Satin Bronze Glass "1J"



Fumè glass

STANDARD DIMENSIONS	2300x2550 mm
STANDARD HEIGHT	h. 2200/2290 mm
GLASS THICKNESS	6/8 mm
HANDLE	aluminum/wood
HANDLE HEIGHT	58 cm
POWER SUPPLY	400V - Specify before the order
NUMBER OF PEOPLE MAX.	4 (2300x2550 mm)
DOOR FINISH	transparent tempered glass
BENCH FINISH	Ayous wood
LIGHTING	LED
EXTERNAL PROTECTION	Waterproof paint (wood version)
ROOF	Optional

### FEATURES/COMPONENTS

Electric stove with lava stones  
 Integrated controls on the stove  
 LED under-bench light  
 Hourglass with sand for 15 minutes time duration.  
 Thermo-hygrometer for monitoring temperature and humidity inside the sauna.  
 Wooden tub and ladle.  
 Handle drilled directly into the glass  
 Walls are made of 32 mm thick fir wood.  
 6 mm thick transparent tempered glass door  
 Solid fir wood benches  
 Removable wooden floor



### HOME AUTOMATION CONNECTION PRE-SETUP:

The sauna can be integrated with compatible home automation systems thanks to the preconfigured electrical board. This allows the heater to be turned on and off directly through the system, providing advanced Comfort and convenience.

An aerial photograph of a vast forest during sunrise. The sun is low on the horizon, casting long, golden rays of light through the trees. A thick layer of mist or fog fills the valley between the hills, creating a dreamy atmosphere. The trees in the foreground are illuminated with a warm, golden light, while the background shows rolling hills and mountains under a clear sky.

**KARMA**  
SAUNA  
PIVOT



Compatta, funzionale ed essenziale: la sauna Karma è la scelta ideale per chi desidera un'autentica esperienza finlandese anche in spazi ridotti. Pensata per ambienti domestici contenuti o mini spa, unisce design intelligente e materiali naturali, posizionandosi come proposta entry-level nella gamma Megius.

Realizzata interamente in legno di abete con nodosità a vista che ne valorizzano l'estetica, presenta un aspetto sobrio ed equilibrato, con doghe verticali che rivestono sia l'interno che l'esterno. La porta centrale in vetro temperato trasparente da 8 mm, larga 52 cm, è completata da una maniglia in legno e chiusura magnetica, mentre la pedana a tappeto in legno riduce al minimo gli ingombri senza rinunciare alla funzionalità.

Compact, functional, and essential: the Karma sauna is the ideal choice for those seeking an authentic Finnish experience in small spaces. Designed for compact domestic environments or mini spas, it combines intelligent design and natural materials, positioned as an entry-level option in the Megius range.

Made entirely of natural fir wood with visible knots that enhance its aesthetic, the sauna features a sober and balanced appearance, with vertical slats covering both the interior and exterior. The 8 mm thick tempered glass door, 52 cm wide, is completed with a wood handle and magnetic closure, while the wooden floor mat minimizes space usage without sacrificing functionality.









Due panche ad angolo di altezze diverse ottimizzano la distribuzione del calore, mentre l'illuminazione a LED posta dietro la panca superiore crea un'atmosfera intima e rilassante. Inclusi: clessidra, termoigrometro, mastello e mestolo. Disponibile in due misure: 160x100 cm e 190x130 cm, altezza 200 cm.

Two corner benches of different heights optimize heat distribution, and LED lighting behind the top bench creates an intimate, relaxing atmosphere. Included: hourglass, thermo-hygrometer, bucket, and ladle. Available in two sizes: 160x100 cm and 190x130 cm, with a height of 200 cm.





Karma: sobrietà nordica e resistenza nel tempo, anche all'esterno. Pur mantenendo un'estetica compatta e minimalista, Karma è proposta anche con finiture esterne verniciate in tonalità bianco luminoso o nero intenso, pensate per integrarsi armoniosamente in contesti outdoor riparati, come terrazze coperte o angoli di giardino protetti. Questa variante amplia le possibilità di installazione, mantenendo lo stile naturale del legno e aggiungendo una protezione extra contro gli agenti atmosferici indiretti. La verniciatura conferisce alla sauna un aspetto contemporaneo e curato, capace di valorizzare lo spazio in cui viene collocata. Una soluzione accessibile ma completa, che porta il benessere finlandese anche all'aperto, con equilibrio tra estetica e durabilità.

Karma: Nordic simplicity and long-lasting performance, even outdoors. While compact and minimalist in design, Karma is also available with painted exterior finishes in elegant bright white or deep black, making it ideal for protected outdoor areas such as covered terraces or sheltered garden corners. These finishes enhance resistance to indirect outdoor exposure, extending the sauna's lifespan while maintaining its sleek, modern aesthetic. The painted wood cladding blends harmoniously into various outdoor settings, offering a contemporary look that elevates any space. A complete and accessible solution that brings the essence of Finnish wellness outside, balancing design and durability.



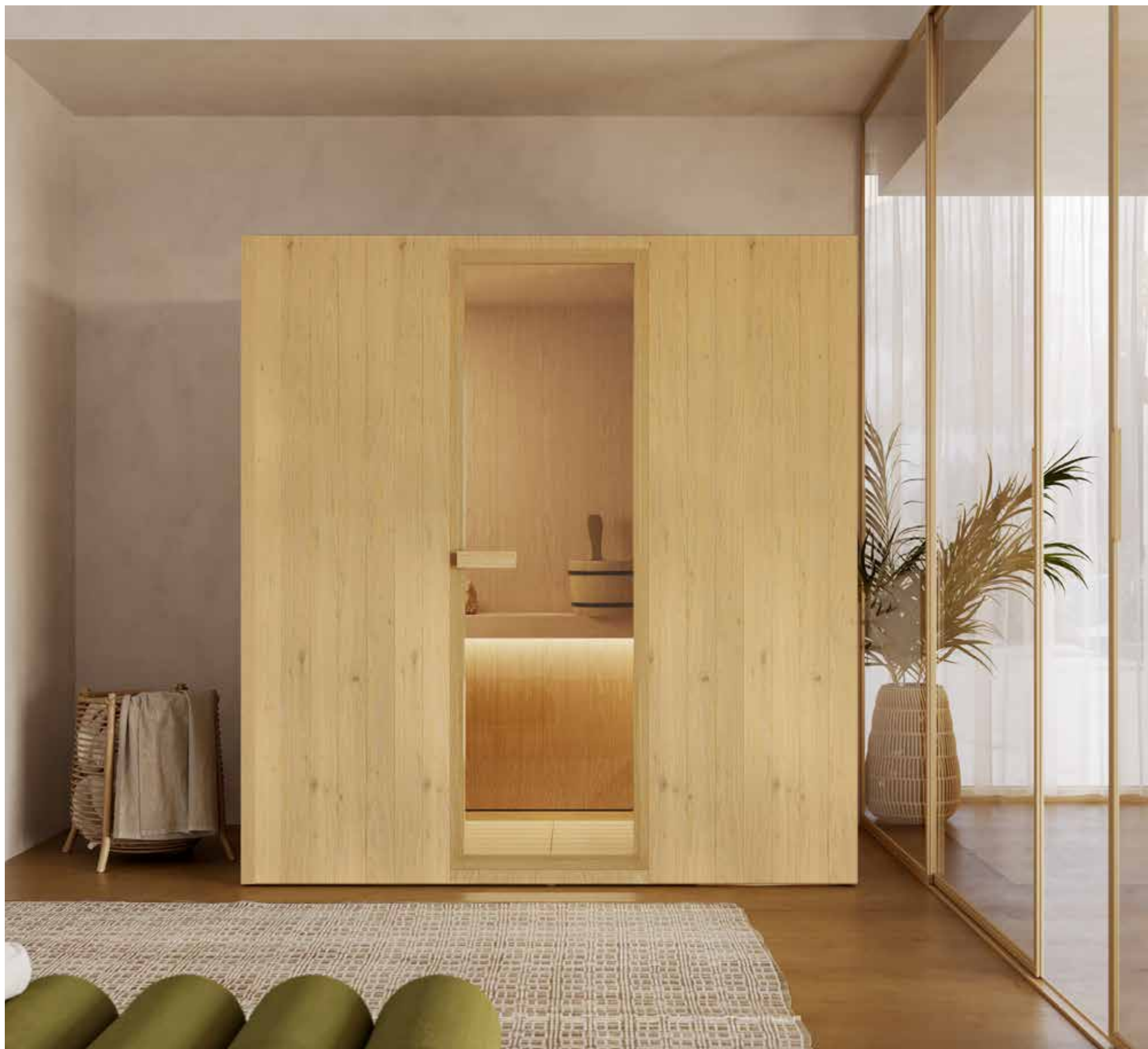

## SAUNA FINLANDESE

### FINITURE LEGNO



Abete Classic "Z"

### FINITURE VETRO



Vetro Trasparente "P"

DIMENSIONI STANDARD	1600x1000 mm
	1900x1300 mm
ALTEZZA STANDARD	h. 2000 mm
SPESSORE DEI VETRI	8 mm
MANIGLIA	legno abete classico
ALIMENTAZIONE ELETTRICA	220V - Specificare prima dell'ordine
NUMERO DI PERSONE MAX.	2/4 (art. 1900x1300)
MATERIALE PORTA	vetro temperato trasparente
MATERIALE PANCA	legno Abete Classic
ILLUMINAZIONE	Luce a LED retro panca
TEMPI DI SPEDIZIONE	2-3 settimane

### CARATTERISTICHE/COMPONENTI

Stufa elettrica con pietre laviche  
 Comandi integrati sulla stufa  
 Luce a LED retro panca  
 Clessidra con sabbia per durata tempo da 15 minuti.  
 Termoigrometro per controllo temperatura e umidità all'interno della sauna.  
 Mastello e mestolo in legno.  
 Maniglia in legno.  
 Pareti in legno di Abete con spessore 44 mm.  
 Porta in vetro trasparente temperato da 8 mm di spessore  
 Panche in legno massello abete  
 Pedana in legno removibile

## FINNISH SAUNA

### WOOD FINISHES



Classic Fir "Z"

### GLASS FINISHES



Transparent Glass "P"

STANDARD DIMENSIONS	1600x1000 mm
	1900x1300 mm
STANDARD HEIGHT	h. 2000 mm
GLASS THICKNESS	8 mm
HANDLE	Classic Fir wood
POWER SUPPLY	220V - Specify before the order
NUMBER OF PEOPLE MAX.	2/4 (art. 1900x1300)
DOOR FINISH	transparent tempered glass
BENCH FINISH	Classic Fir wood
LIGHTING	led inserted in the bench
DELIVERY TIME	2-3 weeks

### FEATURES/COMPONENTS

Electric stove with lava stones  
 Integrated controls on the stove  
 LED under-bench light  
 Hourglass with sand for 15 minutes time duration.  
 Thermo-hygrometer for monitoring temperature and humidity inside the sauna.  
 Wooden tub and ladle.  
 Wooden handle.  
 Walls are made of 44 mm thick fir wood.  
 8 mm thick transparent tempered glass door  
 Solid fir wood benches  
 Removable wooden floor

A photograph of a dense forest of evergreen trees, likely spruce or fir, heavily laden with snow. The trees are dark green, contrasting with the white snow. The sky is a uniform, overcast grey, suggesting a winter day. The overall mood is serene and quiet.

**TAO**  
SAUNA  
PIVOT



Tra i migliori modi per purificare il corpo e liberare la mente, Tao Sauna rappresenta l'ingresso perfetto nel mondo del benessere finlandese.

Prodotta in un'unica versione completamente in legno di abete naturale, offre un'atmosfera autentica anche grazie alle panche e alle pedane removibili. L'incastro tra vetro e legno dona eleganza e luminosità, restituendo un design innovativo e raffinato che si adatta perfettamente a qualsiasi ambiente.

Among the best ways to purify the body and clear the mind, Tao Sauna is the perfect entry point into the world of Finnish wellness.

Offered in a single version entirely made of natural spruce wood, it recreates an authentic atmosphere, including removable benches and platforms. The seamless integration of glass and wood creates an elegant, bright look with a refined and innovative design, perfectly suited to any environment.





A differenza delle classiche saune finlandesi totalmente in legno, Tao Sauna introduce elementi in vetro per un'estetica più moderna e funzionale.

La parete posteriore accoglie la panca con illuminazione LED integrata sotto la seduta, mentre le pareti laterali sono in abete naturale e quella frontale completamente in vetro. La porta battente in vetro da 6 mm con apertura reversibile, cerniere in ottone cromato e maniglia forata orizzontale agevola l'accesso e migliora la ventilazione interna.

Unlike traditional Finnish saunas made entirely of wood, Tao Sauna features glass elements for a more modern and functional aesthetic. The back wall houses a bench with integrated LED lighting beneath the seat, while the side walls are made of natural spruce and the front wall is fully glazed. The 6 mm thick hinged glass door, with reversible opening, chrome-plated brass hinges, and a horizontal slotted handle, ensures easy access and natural air circulation inside the sauna.





La sauna **Tao** è dotata di una stufa elettrica reversibile, adeguata alle dimensioni e posta nella parte anteriore della sauna stessa; in fase di installazione può essere posta a destra o a sinistra in base alle esigenze.

La stufa, racchiusa all'interno di un frontale di legno abete, si può regolare direttamente all'interno della sauna grazie ad una manopola di comando manuale.

Una volta attivata la stufa e versando sopra alle pietre laviche l'acqua presente nel mastello, si formerà il vapore, andando a variare l'umidità tra il 10 ed il 20%.

The **Tao** sauna is equipped with a reversible electric heater, suitable for its size and located at the front of the sauna itself; during installation, it can be placed on the right or left as required.

The stove, enclosed in a fir wood front, can be regulated directly inside the sauna thanks to a manual control knob.

Once the stove is switched on and the water in the tank is poured over the lava stones, steam is formed, varying the humidity between 10 and 20%.

La vera particolarità e punto di forza di Tao Sauna è il fatto di avere una porta battente in vetro 6mm con apertura reversibile con la presenza di 2 cerniere in ottone cromato, che agevola l'accesso e la "non presenza" della maniglia forata posizionata in orizzontale facilita il ricambio naturale dell'aria all'interno della sauna.

The real peculiarity and strength of Tao Sauna is the fact that it has a 6mm glass hinged door with a reversible opening with the presence of 2 brass hinges, which facilitates access and the "non-presence" of the perforated handle positioned horizontally facilitates the natural exchange of air inside the sauna.



## UNICA NEL SUO GENERE

Tao Sauna viene considerata come un perfetto entry level per iniziare a conoscere il mondo wellness Megius, facile da montare è disponibile in un'unica finitura ma esistono varie tipologie di misure adattabili ad ogni tipo di spazio delle case moderne e agli ambienti dell'hotellerie. Disponibile come optional lo sgabello in abete naturale.

## UNIQUE IN ITS KIND

Tao Sauna is considered as a perfect entry-level to start getting to know the Megius wellness world, easy to assemble it is available in a single finish but there are various types of sizes adaptable to any type of space in modern homes and hotellerie environments. A natural spruce stool is available as an optional extra.











**TERMOIGROMETRO SAUNA**  
SAUNA THERMOHYGROMETER



**STUFA CON COMANDO INTEGRATO**  
STOVE WITH INTEGRATED CONTROL



**POGGIATESTA**  
HEADREST



**CLESSIDRA**  
HOURGLASS



**MANIGLIA FORATA NEL VETRO**  
HANDLE PERFORATED IN THE GLASS

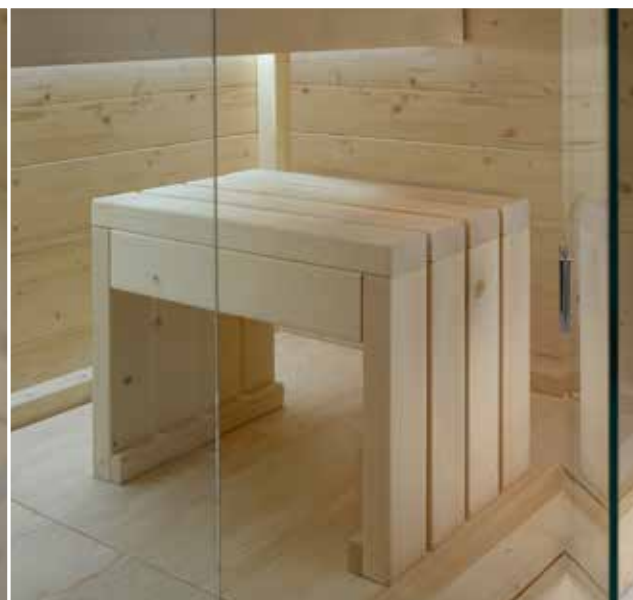

**SEDUTA IN ABETE (OPTIONAL)**  
SITTING IN FIR (OPTIONAL)

## SAUNA FINLANDESE

## FINITURE LEGNO



Legno Abete Classic "Z"

## FINITURE VETRO



Vetro Trasparente "P"

DIMENSIONI STANDARD	1400x1000 mm
	1700x1000 mm
	2000x1000 mm
	1700x1400 mm
	2000x2000 mm
ALTEZZA STANDARD	h. 2055 mm
SPESSORE DEI VETRI	6 mm
MANIGLIA	vetro forato
ALTEZZA DELLA MANIGLIA	100 mm
ALIMENTAZIONE ELETTRICA	220-380V - Specificare prima dell'ordine
NUMERO DI PERSONE MAX.	4 (art. 2000x2000)
MATERIALE PORTA	vetro temperato trasparente
MATERIALE PANCA	legno Abete Classic
ILLUMINAZIONE	Luce a LED retro panca
TEMPI DI SPEDIZIONE	5-6 settimane - * 2-3 settimane

## CARATTERISTICHE/COMPONENTI

Stufa elettrica con pietre laviche  
 Comandi integrati sulla stufa  
 Luce a LED retro panca  
 Clessidra con sabbia per durata tempo da 15 minuti.  
 Termoigrometro per controllo temperatura e umidità all'interno della sauna.  
 Mastello e mestolo in legno.  
 Maniglia forata direttamente nel vetro  
 Pareti in legno di Abete con spessore 32 mm.  
 Porta in vetro trasparente temperato da 6 mm di spessore  
 Panche in legno massello abete  
 Pedana in legno removibile

**PREDISPOSIZIONE COLLEGAMENTO DOMOTICA  
 (SOLO CON ALLESTIMENTO TOUCH DISPLAY):**

La sauna può essere integrata con sistemi di domotica compatibili, grazie alla scheda elettronica predisposta. Questo permette di gestire l'accensione e lo spegnimento della stufa e dei led direttamente tramite il sistema, offrendo Comfort e praticità avanzati.

## SAUNA AD INFRAROSSI

La sauna ad infrarossi utilizza raggi infrarossi per riscaldare direttamente il corpo senza aumentare troppo la temperatura ambientale (30-60°C). È perfetta per chi desidera un effetto più delicato, beneficiando di un calore profondo e mirato, adatto anche a chi tollera meno il caldo intenso.

## FINNISH SAUNA

### WOOD FINISHES



Classic Fir wood "Z"

### GLASS FINISHES



Transparent Glass "P"

STANDARD DIMENSIONS	1400x1000 mm
	1700x1000 mm
	2000x1000 mm
	1700x1400 mm
	2000x2000 mm
STANDARD HEIGHT	h. 2055 mm
GLASS THICKNESS	6 mm
HANDLE	perforated glass
HANDLE HEIGHT	100 mm
POWER SUPPLY	220-380V - Specify before the order
NUMBER OF PEOPLE MAX.	4 (art. 2000x2000)
DOOR FINISH	transparent tempered glass
BENCH FINISH	Classic Fir wood
LIGHTING	led inserted in the bench
DELIVERY TIME	5-6 weeks - * 2-3 weeks



#### HOME AUTOMATION CONNECTION PRE-SETUP

##### **(ONLY WITH TOUCH DISPLAY SETUP):**

The sauna can be integrated with compatible home automation systems thanks to the preconfigured electrical board. This allows the heater to be turned on and off directly through the system, providing advanced Comfort and convenience.

#### INFRARED SAUNA

The infrared sauna uses infrared rays to directly heat the body without significantly increasing the ambient temperature (30-60°C). It is perfect for those seeking a gentler effect, benefiting from deep and targeted warmth, ideal even for those who tolerate intense heat less.

#### FEATURES/COMPONENTS

Electric stove with lava stones  
 Integrated controls on the stove  
 LED under-bench light  
 Hourglass with sand for 15 minutes time duration.  
 Thermo-hygrometer for monitoring temperature and humidity inside the sauna.  
 Wooden tub and ladle.  
 Handle drilled directly into the glass  
 Walls are made of 32 mm thick fir wood.  
 6 mm thick transparent tempered glass door  
 Solid fir wood benches  
 Removable wooden floor



EXEN  
SAUNA  
SLIDING

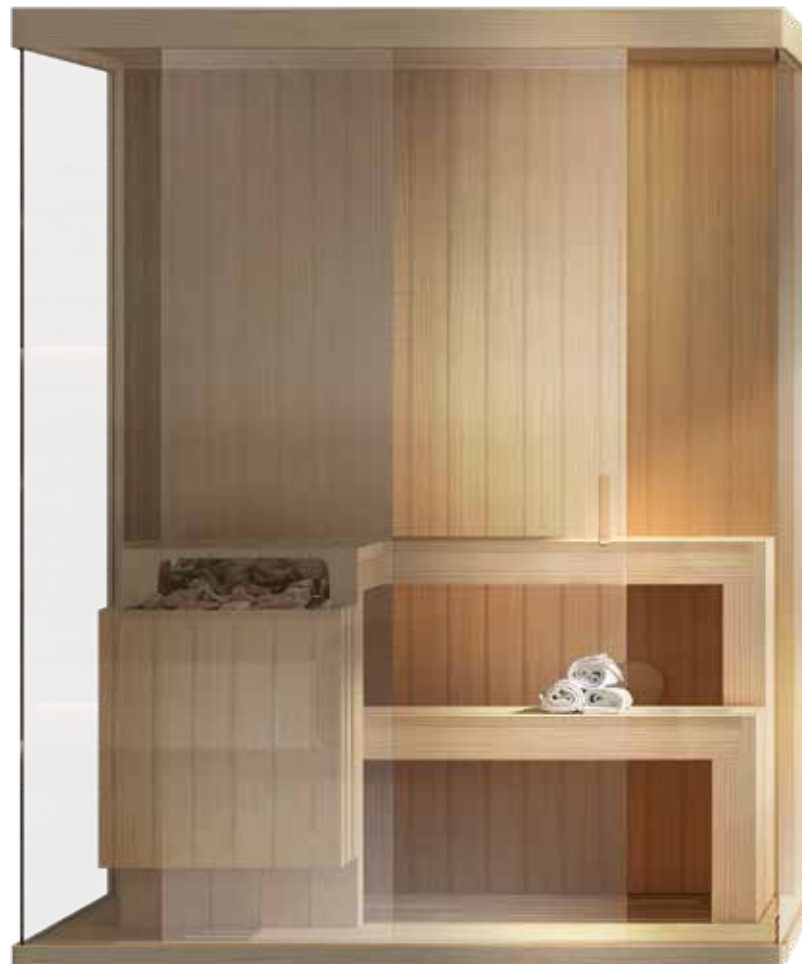

Nella Sauna  
Finlandese Exen  
possiamo vedere  
l'esaltazione del  
vetro: **rivestimenti  
interni ed esterni in  
vetro**

La parete di fondo e i vari componenti interni sono in abete con venature verticali, mentre le due pareti laterali e l'entrata sono in vetro temperato trasparente o retroverniciato da 8mm.

In the Finnish  
Sauna Exen we can  
see the exaltation  
of glass: **interior  
and exterior glass  
paneling**

The back wall and the various interior components are made of spruce with vertical grain, while the two side walls and the entrance are made of 8 mm clear tempered glass or back painted.







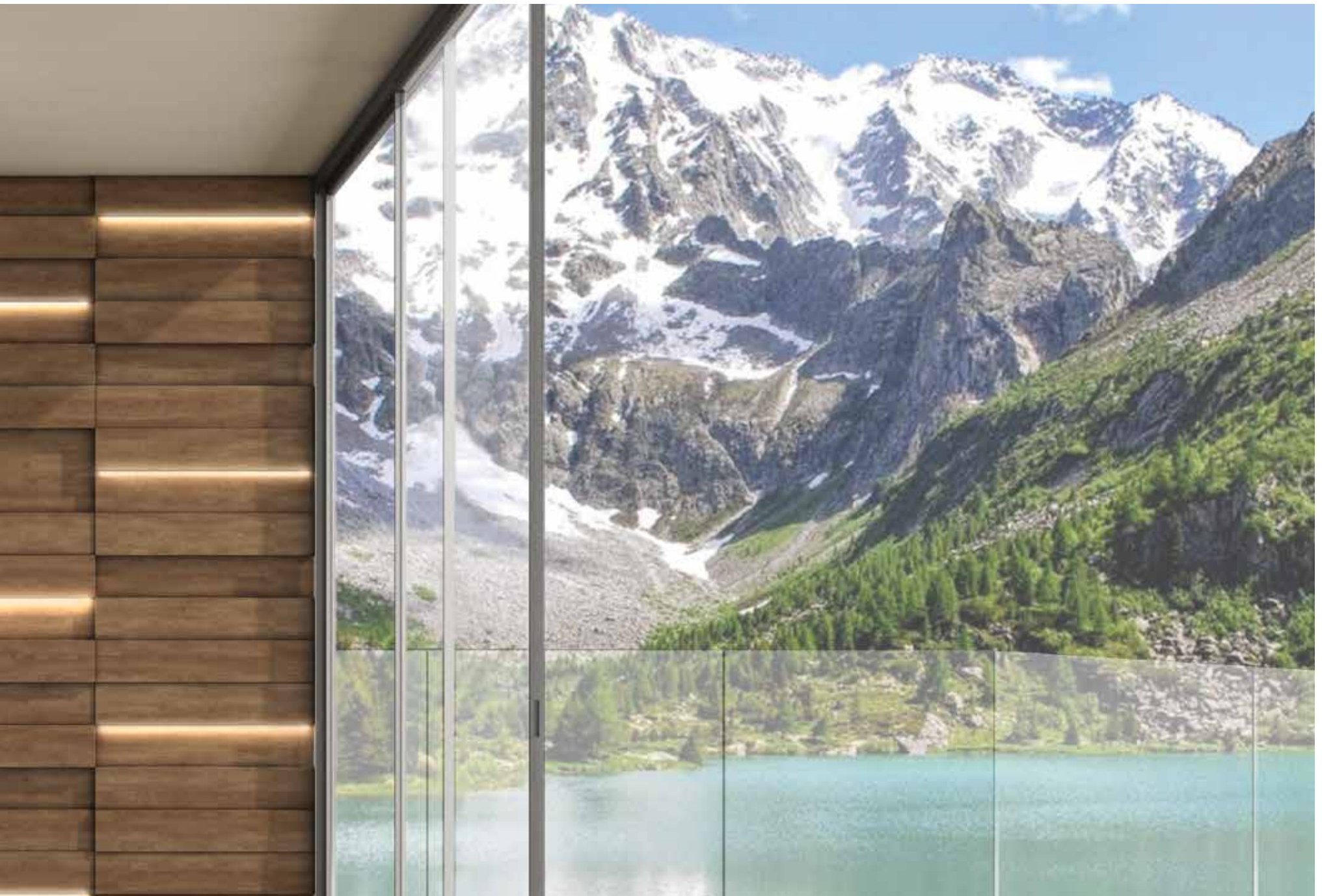

## + VETRO + TRASPARENZA

L'incastro degli elementi tra vetro e legno regalano alla vista un prodotto raffinato, luminoso, dal design innovativo e ricercato. Exen è composta principalmente da una parete di fondo in legno abete dove sono incassati i due livelli panche, mentre le pareti di rivestimento laterali sono in vetro.

## + GLASS + TRANSPARENCY

The interlocking of the elements between glass and wood gives the view a refined, luminous product with an innovative and refined design. Exen is mainly composed of a back wall in fir wood where the two bench levels are fitted, while the covering side walls are in glass.











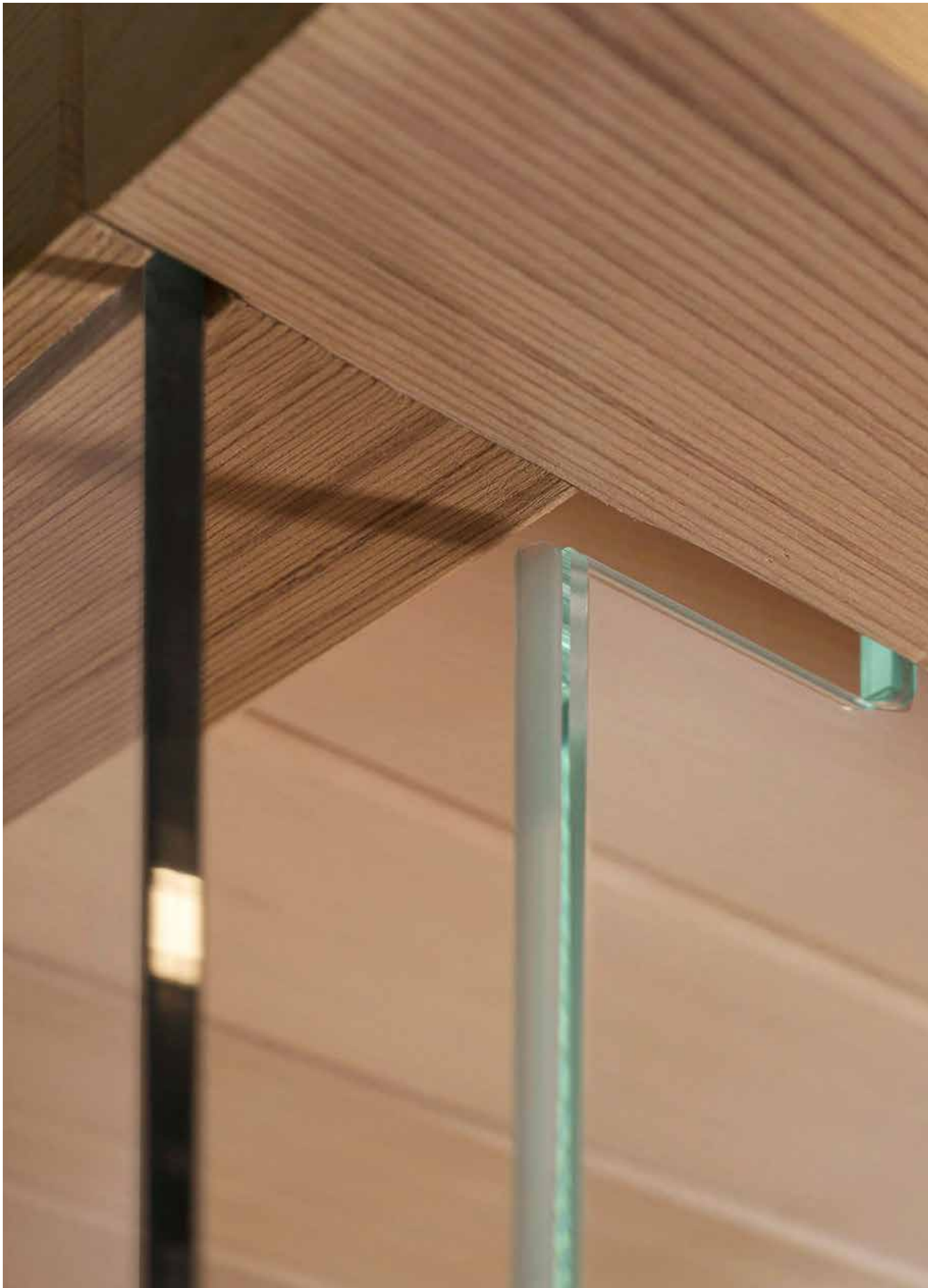

## UNICA NEL SUO GENERE: **SCORREVOLE**

La vera particolarità e punto di forza di Exen Sauna è il fatto di avere una porta scorrevole che agevola l'accesso e la "non presenza" di una maniglia facilita il ricambio naturale dell'aria all'interno della sauna.

## UNIQUE IN ITS KIND: **SLIDING**

The real special feature and strength of Exen Sauna is the fact that it has a sliding door that facilitates access and the "non-presence" of a handle facilitates the natural exchange of air inside the sauna.







**TERMOIGROMETRO SAUNA**  
SAUNA THERMOHYGROMETER



**MASTELLO E MESTOLO**  
BUCKET AND LADLE



**STUFA CON PIETRE**  
STOVE WITH STONES



**CLESSIDRA**  
HOURGLASS



**PEDANA CON VETRO SCORREVOLE**  
FOOTBOARD WITH SLIDING GLASS



**MANIGLIA FORATA**  
PERFORATED HANDLE

## SAUNA FINLANDESE SLIDING

## FINITURE LEGNO



Hemlock "E"



Abete Classic "Z"



Cedro "C"



Noce canaletto "Q"

## PEDANA E PANCA



Legno Ayous

## FINITURE VETRO



Vetro Trasparente "P"



Vetro Extra-chiaro "X"



Vetro Retroverniciato Nero "Z"

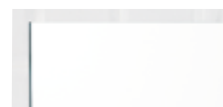

Vetro Retroverniciato Bianco "1"

DIMENSIONI SU MISURA	larghezza max. 2000 mm
	profondità max. 2000 mm
	altezza max. 2110 mm
DIMENSIONI STANDARD	1500x1200 mm
	1700x1300 mm
	2000x1500 mm
ALTEZZA STANDARD	h. 2100 mm
SPESSORE DEI VETRI	8 mm
MANIGLIA	vetro forato
DIMENSIONE DELLA MANIGLIA	160 mm
ALIMENTAZIONE ELETTRICA	220-380V - Specificare prima dell'ordine
NUMERO DI PERSONE MAX.	3 (art. 2100x1500)
CONSUMI	4,5 kW. min - 6 kW. max
MATERIALE PORTA	vetro temperato trasparente
MATERIALE PANCA	legno ayous
ILLUMINAZIONE	Luce a LED retro panca
TEMPI DI SPEDIZIONE	5-6 settimane

## CARATTERISTICHE/COMPONENTI

Stufa elettrica con pietre laviche, con accensione a comando integrato

Sistema di apertura con porta SCORREVOLE

Parete in vetro con appoggio a muro in finitura vetro retroverniciato bianco o nero (solo nella soluzione ANGOLO e NICCHIA)

Clessidra con sabbia per durata tempo da 15 minuti.

Termoigrometro per controllo temperatura e umidità all'interno della sauna

Mastello e mestolo in legno

Pedana in legno removibile

**PREDISPOSIZIONE COLLEGAMENTO DOMOTICA****(SOLO CON ALLESTIMENTO TOUCH DISPLAY):**

La sauna può essere integrata con sistemi di domotica compatibili, grazie alla scheda elettronica predisposta. Questo permette di gestire l'accensione e lo spegnimento della stufa e dei led direttamente tramite il sistema, offrendo Comfort e praticità avanzati.

## SLIDING FINNISH SAUNA

### WOOD FINISHES



Hemlock "E"



Classic Fir "Z"



Cedar "C"



Canaletto walnut "Q"

### PLATFORM AND BENCH



Ayous wood

### GLASS FINISHES



Transparent Glass "P"



Extra-clear glass "X"



Black back-painted glass "Z"

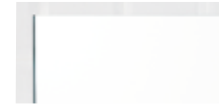

White back-painted glass "1"

CUSTOM SIZE	width max. 2000 mm
	depth max. 2000 mm
	height max. 2110 mm
STANDARD DIMENSIONS	1500x1200 mm
	1700x1300 mm
	2000x1500 mm
STANDARD HEIGHT	h. 2100 mm
GLASS THICKNESS	8 mm
HANDLE	perforated glass
HANDLE HEIGHT	160 mm
POWER SUPPLY	220-380V - Specify before the order
NUMBER OF PEOPLE MAX.	3 (art. 2100x1500)
CONSUMPTION	4,5 kW. min - 6 kW. max
DOOR FINISH	transparent tempered glass
BENCH FINISH	wood ayous
LIGHTING	led inserted in the bench
DELIVERY TIME	5-6 weeks

### FEATURES/COMPONENTS

Electric stove with lava stone, with integrated control ignition

Opening system with SLIDING door

A glass wall with wall support in white or black back-painted glass finish (only in the CORNER and NICHE solution)

Hourglass with sand for 15 minutes time duration.

Thermo-hygrometer for monitoring temperature and humidity inside the sauna.

Wooden tub and ladle.

Removable wooden floor slats



#### HOME AUTOMATION CONNECTION PRE-SETUP

##### **(ONLY WITH TOUCH DISPLAY SETUP):**

The sauna can be integrated with compatible home automation systems thanks to the preconfigured electrical board. This allows the heater to be turned on and off directly through the system, providing advanced Comfort and convenience.

A long wooden pier extends from the foreground into a calm lake. The sky is filled with soft, colorful clouds in shades of blue, orange, and yellow, suggesting a sunset or sunrise. The sun is visible on the horizon to the right, casting a warm glow over the water. The pier is made of dark wooden planks and has several vertical posts along its length.

EXEN  
SAUNA  
PIVOT



Siamo abituati a vedere saune finlandesi composte unicamente da legno, mentre Exen si discosta da questa concezione,

essendo composta principalmente da una parete di fondo in legno abete dove sono incassati i due livelli panche mentre le pareti di rivestimento sono in vetro.

We are accustomed to seeing Finnish saunas made entirely of wood, but Exen differs from this concept,

as it is composed mainly of a fir wood back wall where the two bench levels are embedded, while the covering walls are made of glass.









## ANCHE CON APERTURA **BATTENTE**

Exen Sauna è disponibile anche nella versione battente, mantenendo sempre una linea pulita, ricercata e dal design innovativo.

## ALSO WITH **HINGED** OPENING

Exen Sauna is also available in a hinged version, always maintaining a clean, refined line and innovative design.



# VERA ESSENZA DELLA SAUNA

L'incastro degli elementi tra vetro e legno, regalano alla vista un prodotto raffinato, luminoso, dal design innovativo e ricercato.

# THE TRUE ESSENCE OF THE SAUNA

The interlocking elements of glass and wood create a refined, luminous product with an innovative and refined design.

## SAUNA FINLANDESE PIVOT

## FINITURE LEGNO



Hemlock "E"

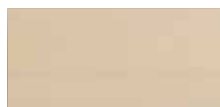

Abete Classic "Z"



Cedro "C"



Noce canaletto "Q"

## PEDANA E PANCA



Legno Ayous

## FINITURE VETRO



Vetro Trasparente "P"



Vetro Extra-chiaro "X"



Vetro Retroverniciato Nero "Z"



Vetro Retroverniciato Bianco "1"

DIMENSIONI SU MISURA	larghezza max. 2000 mm
	profondità max. 2000 mm
	altezza max. 2110 mm
DIMENSIONI STANDARD	1500x1200 mm
	1700x1300 mm
	2000x1500 mm
ALTEZZA STANDARD	h. 2100 mm
SPESSORE DEI VETRI	8 mm
MANIGLIA	vetro forato
ALTEZZA DELLA MANIGLIA	160 mm
ALIMENTAZIONE ELETTRICA	220-380V - Specificare prima dell'ordine
NUMERO DI PERSONE MAX.	3 (art. 2100x1500)
CONSUMI	4,5 kW. min - 6 kW. max
MATERIALE PORTA	vetro temperato trasparente
MATERIALE PANCA	legno ayous
ILLUMINAZIONE	Luce a LED retro panca
TEMPI DI SPEDIZIONE	5-6 settimane

## CARATTERISTICHE/COMPONENTI

Stufa elettrica con pietre laviche, con accensione a comando integrato

Sistema di apertura con porta BATTENTE.

Parete in vetro con appoggio a muro in finitura vetro retroverniciato bianco o nero (solo nella soluzione ANGOLO e NICCHIA)

Clessidra con sabbia per durata tempo da 15 minuti.

Termoigrometro per controllo temperatura e umidità all'interno della sauna

Mastello e mestolo in legno

Pedana in legno removibile

**PREDISPOSIZIONE COLLEGAMENTO DOMOTICA****(SOLO CON ALLESTIMENTO TOUCH DISPLAY):**

La sauna può essere integrata con sistemi di domotica compatibili, grazie alla scheda elettronica predisposta. Questo permette di gestire l'accensione e lo spegnimento della stufa e dei led direttamente tramite il sistema, offrendo Comfort e praticità avanzati.

## PIVOT FINNISH SAUNA

### WOOD FINISHES



Hemlock "E"



Classic Fir "Z"



Cedar "C"



Canaletto walnut "Q"

### PLATFORM AND BENCH



Ayous wood

### GLASS FINISHES



Transparent Glass "P"



Extra-clear glass "X"



Black back-painted glass "Z"

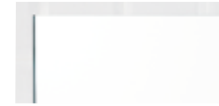

White back-painted glass "1"

CUSTOM SIZE	width max. 2000 mm
	depth max. 2000 mm
	height max. 2110 mm
STANDARD DIMENSIONS	1500x1200 mm
	1700x1300 mm
	2000x1500 mm
STANDARD HEIGHT	h. 2100 mm
GLASS THICKNESS	8 mm
HANDLE	perforated glass
HANDLE HEIGHT	160 mm
POWER SUPPLY	220-380V - Specify before the order
NUMBER OF PEOPLE MAX.	3 (art. 2100x1500)
CONSUMPTION	4,5 kW. min - 6 kW. max
DOOR FINISH	transparent tempered glass
BENCH FINISH	wood ayous
LIGHTING	led inserted in the bench
DELIVERY TIME	5-6 weeks

### FEATURES/COMPONENTS

Electric stove with lava stone, with integrated control ignition  
 Opening system with HINGED door  
 A glass wall with wall support in white or black back-painted glass finish (only in the CORNER and NICHE solution)  
 Hourglass with sand for 15 minutes time duration.  
 Thermo-hygrometer for monitoring temperature and humidity inside the sauna.  
 Wooden tub and ladle.  
 Removable wooden floor slats



#### HOME AUTOMATION CONNECTION PRE-SETUP

##### (ONLY WITH TOUCH DISPLAY SETUP):

The sauna can be integrated with compatible home automation systems thanks to the preconfigured electrical board. This allows the heater to be turned on and off directly through the system, providing advanced Comfort and convenience.

A serene sunset scene over a large body of water. The sun is low on the horizon, creating a bright orange and red glow that reflects on the water's surface. In the foreground, the silhouettes of four people are visible, sitting on a grassy bank and looking out at the water. The sky is filled with soft, golden light, and a line of trees is visible on the far shore.

# NIRVANA SERIES

SAUNA / BIOSAUNA  
COMBI HAMMAM



NIRVANA  
SAUNA  
SAUNA / BIOSAUNA



NIRVANA  
COMBI YOUNG  
SAUNA + HAMMAM



NIRVANA  
COMBI 1  
SAUNA + HAMMAM

Nirvana è la serie di prodotti Megius che permette di integrare diverse funzioni wellness all'interno dell'area domestica e dell'hotellerie pensata in quattro soluzioni differenti:

sauna finlandese, bio sauna, hammam e doccia. In Nirvana Sauna possiamo vedere **rivestimenti esterni** in vetro e colorazioni interne come nuova tendenza.

I rivestimenti esterni comprendono 2 tipi di legno: abete classico ed Hemlock in versione impiallacciata, e la presenza di vetri bianco o nero retroverniciati.

Per i rivestimenti interni invece, si può scegliere tra il legno hemlock o l'abete classico verniciato all'acqua in versione nera o bianca per la parete di fondo, mentre le pareti laterali restano impiallacciate.

Nirvana is the Megius product series that allows you to integrate different wellness functions inside the home area and the hotellerie designed in four different solutions:

Finnish sauna, bio sauna, hammam and shower. In Nirvana Sauna we can see **external glass coverings** and internal colors as a new trend.

The exterior cladding includes 2 types of wood: classic fir and Hemlock in a veneered version, and types of back-painted white or black glass.

For the interior cladding, there is a choice of water-varnished hemlock or fir wood in black or white for the back wall and veneered sidewalls.

A silhouette of a person with their arms raised in a gesture of praise or joy, set against a vibrant sunset background. The sun is a bright, glowing orb on the right side, casting a warm, golden light across the sky. The person's silhouette is dark against the lighter background, with their arms reaching towards the top left corner. The overall mood is serene and uplifting.

**NIRVANA**  
SAUNA  
BIOSAUNA  
WOOD AND GLASS



In **Nirvana Sauna/BioSauna** possiamo vedere l'esaltazione della migliore progettualità della sauna finlandese: **rivestimenti esterni** e colorazioni interne come nuova tendenza.

In **Nirvana Sauna/biosauna** we can see the exaltation of the best design of finnish sauna: **external coverings** and internal colors as the new trend.















La **BIO SAUNA**, anche detta calidarium o tepidarium, è una sauna intermedia tra calore e vapore che sfrutta le proprietà rigeneranti e purificanti per ottenere una sensazione di calore avvolgente che non raggiunge mai temperature oltre i 50/60°C ed il livello di umidità non supera mai il 70%. Essa si avvale dell'ausilio di specifici olii essenziali che vengono sprigionati tramite la vaporizzazione di erbe essiccate e fieno; tali piante officinali diffondono aromi che penetrano nei tessuti attraverso i pori della pelle e producono un piacevole effetto emolliente e rivitalizzante sulla pelle.

The **BIO-SAUNA**, also known as calidarium or tepidarium, is an intermediate sauna between heat and steam that exploits the regenerating and purifying properties to obtain an enveloping sensation of heat that never reaches temperatures above 50/60°C and the humidity level never exceeds 70%. It uses specific essential oils that are released through the vaporization of dried herbs and hay; these officinal plants diffuse aromas that penetrate the tissues through the pores of the skin and produce a pleasant emollient and revitalizing effect on the skin.

All'interno della sauna, troverete un elegante e indispensabile mastello in legno, tradizionale della sauna finlandese. Il mastello ha una capienza massima di 5 litri, l'impugnatura singola e l'interno in plastica amovibile al fine di evitare perdite conferisce al prodotto anche una maggiore durata oltre che facilità di pulizia. In abbinata al mastello, troverete anche il mestolo di legno tradizionale per sauna finlandese, che permette di versare l'acqua contenuta all'interno del mastello sulle pietre laviche calde della stufa per favorire l'emanazione del vapore.

Inside the sauna, you will find an elegant and indispensable traditional Finnish sauna wooden tub. The tank has a maximum capacity of 5 liters, a single handle, and a removable plastic interior to prevent leakage and also gives the product a longer lifespan as well as being easy to clean. The traditional wooden ladle for Finnish saunas is also included. This ladle allows you to pour the water inside the ladle onto the hot stones of the stove to help the steam escape.





Finalmente siete all'interno della sauna dove troverete la stufa(il kiuas), dalla quale viene emanato il vapore caldo e sulla quale sono poste le **pietre calde** (kivet); proprio sopra queste pietre si versa l'acqua contenuta all'interno del secchio in legno (ämpäri) con il mestolo (kaula). In questo modo la temperatura si alza fino ad arrivare tra i 90-100° ed il livello di umidità è veramente basso per far si che il sudore evapori e che la pelle non si riscaldi troppo.

Finally, you are inside the sauna where you will find the stove (kiuas), from which hot steam is emitted and on which the **hot stones** (kivet) are placed; the water contained in the wooden bucket (ämpäri) is poured over these stones with the ladle (kaula). This raises the temperature to between 90 and 100 degrees Celsius, and the humidity level is very low so that sweat evaporates and the skin does not get too hot.

ALL'INTERNO DI OGNI SAUNA È PRESENTE UNA  
CLESSIDRA, MA VOI SAPETE QUAL È IL TEMPO DA  
TRASCORRERE NELLA SAUNA?

Se siete neofiti ed è la vostra prima sauna, si consiglia di non superare i 10 minuti, per le volte successive invece è consigliata una permanenza tra i 10 e 15 minuti, seduti o sdraiati comodamente nella panca in legno, con le gambe piegate e i piedi alla stessa altezza della seduta; trascorso il tempo di permanenza all'interno della sauna, è opportuno di alzarsi con calma per evitare capogiri.

INSIDE EVERY SAUNA THERE IS AN HOURGLASS,  
BUT DO YOU KNOW HOW LONG YOU  
SHOULD SPEND IN THE SAUNA?

If you are a newcomer and it is your first sauna, it is advisable not to exceed 10 minutes, for subsequent times instead it is recommended to stay between 10 and 15 minutes, sitting or lying comfortably on the wooden bench, with your legs bent and your feet at the same height as the seat; once the time of stay inside the sauna, you should get up calmly to avoid dizziness.









## MANIGLIA LEGNO ALLUMINIO

L'unione di due elementi tra l'alluminio esterno e uno strato di legno interno, fanno sì che la maniglia non si surriscaldi. Nasce quindi una maniglia di design che dona una linea pulita ed elegante alla porta della sauna.

## WOOD AND ALUMINIUM HANDLE

The union of two elements, with the inner aluminum covered by an outer layer of wood, ensures that the handle does not overheat. The result is a design handle that gives the sauna door a clean and elegant look.









**TERMOIGROMETRO SAUNA**  
SAUNA THERMOHYGROMETER



**MASTELLO E MESTOLO**  
BUCKET AND LADLE



**POGGIATESTA**  
HEADREST



**CLESSIDRA**  
HOURGLASS



**PEDANA IN ABETE**  
FIR FOOTBOARD



**SEDUTA IN AYOUS**  
SITTING IN AYOUS

## SAUNA FINLANDESE / BIOSAUNA

## RIVESTIMENTO INTERNO



Legno Hemlock "E"



Legno Abete Classic "Z"



Legno Abete Bianco "L"



Legno Abete Nero "T"



Legno Rovere "R"



Legno Olmo "M"



Noce canaletto "Q"

## RIVESTIMENTO ESTERNO IN LEGNO



Legno Hemlock "E"



Legno Abete Classic "Z"

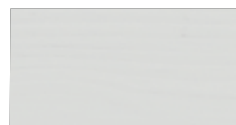

Legno verniciato Bianco "Y"



Legno verniciato Nero "W"



Legno Rovere "R"



Legno Olmo "M"



Noce canaletto "Q"

## PORTA



Vetro Trasparente "P"

## RIVESTIMENTO ESTERNO IN VETRO



Vetro Retroverniciato Bianco "L"



Vetro Retroverniciato Nero "T"

## SEDUTA SAUNA



Legno Ayous

DIMENSIONI SU MISURA	larghezza max. 2200 mm
	profondità max. 2200 mm
	altezza max. 2100 mm
DIMENSIONI STANDARD	1500x1200 mm
	1700x1300 mm
	2000x1500 mm
	2100x1800 mm
ALTEZZA STANDARD	h. 2100 mm
SPESSORE DEI VETRI	8 mm
MANIGLIA	legno/alluminio h. 58 cm
ALTEZZA DELLA MANIGLIA	580 mm
ALIMENTAZIONE ELETTRICA	220-380V - Specificare prima dell'ordine
NUMERO DI PERSONE MAX.	5 (art. 2100x1800)
MATERIALE PORTA	vetro temperato trasparente
MATERIALE PANCA	legno Ayous
ILLUMINAZIONE	Luce a LED retro panca
TEMPI DI SPEDIZIONE	5-6 settimane

## CARATTERISTICHE/COMPONENTI

Stufa elettrica con pietre laviche  
 Centralina digitale professionale con controllo temperatura.  
 Luce a LED retro panca  
 Clessidra con sabbia per durata tempo da 15 minuti.  
 Termoigrometro per controllo temperatura e umidità all'interno della sauna.  
 Mastello e mestolo in legno.  
 Maniglia in legno interno e alluminio esterno con finiture abbinata.  
 Struttura in legno spessore 62 mm con intercapedine termoisolante.  
 Porta in vetro trasparente temperato da 8 mm di spessore  
 Panche in legno massello atermico di Ayous privo di nodi.  
 Doghe a pavimento in legno calpestabile



## PREDISPOSIZIONE COLLEGAMENTO DOMOTICA:

La sauna può essere integrata con sistemi di domotica compatibili, grazie alla scheda elettronica predisposta. Questo permette di gestire l'accensione e lo spegnimento della stufa e dei led direttamente tramite il sistema, offrendo Comfort e praticità avanzati.

## BIOSAUNA

La BIOSAUNA raggiunge temperature più basse (50-60°C) rispetto alla sauna finlandese classica (70-100°C) e presenta un livello di umidità maggiore. Unisce calore e umidità per un'esperienza più delicata e rigenerante, ideale per chi cerca un benessere profondo e rilassante. La sauna finlandese, invece, offre un ambiente secco e molto caldo, favorendo un'intensa sudorazione e un profondo rilassamento muscolare.

## SAUNA AD INFRAROSSI

La sauna ad infrarossi utilizza raggi infrarossi per riscaldare direttamente il corpo senza aumentare troppo la temperatura ambientale (30-60°C). È perfetta per chi desidera un effetto più delicato, beneficiando di un calore profondo e mirato, adatto anche a chi tollera meno il caldo intenso.

# FINNISH SAUNA / BIOSAUNA

## INTERNAL COATING



Wood Hemlock "E"

Classic Fir "Z"

Wood Fir White "L"

Wood Fir Black "T"

Oak wood "R"

Elm wood "M"

Canaletto walnut "Q"

## EXTERIOR WOOD COATING



Wood Hemlock "E"

Classic Fir "Z"

Painted wood White "Y"

Painted wood Black "W"

Oak wood "R"

Elm wood "M"

Canaletto walnut "Q"

## DOOR



Transparent glass "P"

## EXTERIOR GLASS COATING

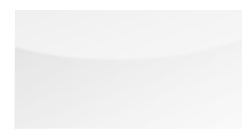

Back-painted glass White "L"



Back-painted glass Black "T"

## SITTING SAUNA



Ayous wood

CUSTOM SIZE	width max. 2200 mm
	depth max. 2200 mm
	height max. 2100 mm
STANDARD DIMENSIONS	1500x1200 mm
	1700x1300 mm
	2000x1500 mm
	2100x1800 mm
STANDARD HEIGHT	h. 2100 mm
GLASS THICKNESS	8 mm
HANDLE	wood/aluminum h. 58 cm
HANDLE HEIGHT	580 mm
POWER SUPPLY	220-380V - Specify before the order
NUMBER OF PEOPLE MAX.	5 (art. 2100x1800)
DOOR FINISH	transparent tempered glass
BENCH FINISH	wood Ayous
LIGHTING	led inserted in the bench
DELIVERY TIME	5-6 weeks

## FEATURES/COMPONENTS

Electric stove with lava stone  
 Professional digital control unit with temperature control.  
 LED light above the bench.  
 Hourglass with sand for 15 minutes time duration.  
 Thermo-hygrometer for temperature and humidity control inside the sauna.  
 Wooden tub and ladle.  
 Handle made of wood inside and aluminum outside with matching finish.  
 Wooden frame 62 mm thick with rock wool insulation space.  
 Transparent tempered glass door 8 mm thick  
 Benches made of solid athermic Ayous wood without knots.  
 Walk-on wooden floorboards



## HOME AUTOMATION CONNECTION PRE-SETUP:

The sauna can be integrated with compatible home automation systems thanks to the preconfigured electrical board. This allows the heater to be turned on and off directly through the system, providing advanced Comfort and convenience.

## BIOSAUNA

The BIOSAUNA reaches lower temperatures (50-60°C) compared to the traditional Finnish sauna (70-100°C) and has a higher humidity level. It combines heat and humidity for a more gentle and rejuvenating experience, ideal for those seeking deep and relaxing wellness. The Finnish sauna, on the other hand, offers a dry and very hot environment, promoting intense sweating and deep muscle relaxation.

## INFRARED SAUNA

The infrared sauna uses infrared rays to directly heat the body without significantly increasing the ambient temperature (30-60°C). It is perfect for those seeking a gentler effect, benefiting from deep and targeted warmth, ideal even for those who tolerate intense heat less.

A person is shown in silhouette, performing a yoga pose (Vrikshasana) on a beach. The background is a vibrant sunset with a bright sun on the right, creating a warm orange and yellow glow. The sky is filled with silhouettes of birds in flight and bare tree branches in the upper right corner. The ocean is visible in the distance, and the foreground shows the silhouette of the person and the beach.

**NIRVANA**  
COMBI 1  
SAUNA + HAMMAM



In questa declinazione del progetto **Nirvana** possiamo ammirare l'esaltazione della combinazione calore e acqua.

Una sorta di yin e yang del benessere, del vetro, del legno e del design in generale: da una parte la sauna finlandese a secco, con interni in legno abete impiallacciato e verniciato all'acqua, dall'altra l'hammam con pareti in vetro retroverniciate. Ecco, quindi, che 2 mondi diversi vengono uniti per creare un unico polo di benessere.

In this declination of the **Nirvana project**, we can admire the exaltation of the combination of heat and water.

A sort of yin-yang of wellbeing, glass, wood, and design in general: on the one hand, the dry Finnish sauna, with interiors in veneered and painted fir wood, and on the other, the hammam with back-painted glass walls. And so two different worlds are brought together to create a single wellness center.





## SAUNA FINLANDESE + HAMMAM

Rigore estetico e affidabilità rappresentano lo standard delle Saune Megius. Vengono impiegati diversi tipi di legno, tutti testati per un funzionamento ottimale nel rispetto della tradizione, e compatibili con lo stress termico prolungato.

## FINNISH SAUNA + HAMMAM

Aesthetic rigor and reliability are the standards in Megius saunas. Different types of wood are used, all of which have been tested for optimal functioning following tradition, and are compatible with the thermal stress over the years that is characteristic of the sauna ritual.



Le misure sono 3355×1381 mm e 4151×1881 mm fruibili in installazioni domestiche o contract: in casa privata, ecco un oggetto bello da esibire, funzionale per il proprio benessere; nell'hotel piccolo o grande che sia, arricchisce le suite più lussuose oppure permette oasi di benessere aperte agli ospiti a basso impatto gestionale e di manutenzione.

The sizes are 3355×1381 mm and 4151×1881 mm. They can be used in domestic or contract installations: in the private home, here is an object that is beautiful to show off, functional for one's wellbeing; in the hotel, whether large or small, it enhances the most luxurious suites or allows for oases of wellbeing open to guests with low management and maintenance impact.

Nirvana Combi 1 ha la funzione di bagno turco ovvero un bagno di vapore che tonifica, rilassa ed elimina le impurità della pelle rendendola elastica.

Nirvana Combi 1 has the function of a Turkish bath, that is, a steam bath that tones, relaxes, and eliminates impurities from the skin, making it elastic.





La tastiera della parte Hammam è composta da sei pulsanti adibiti al controllo della cromoterapia RGB, doccetta, riscaldamento a ventilazione, bagno vapore e regolazione del volume interno.

The keypad on the Hammam part consists of six buttons used to control the RGB color therapy, hand shower, ventilation heating, steam bath, and internal volume control.

Il doccino a mano della parte Hammam è composto da tantissimi microgetti d'acqua ideati per un tuo completo relax.

The handheld shower in the Hammam part is made up of many micro-jets of water, ideal and designed for your complete relaxation.



## MILLE BOLLE BLU

Con l'affermarsi del wellness come stile di vita, anche il mondo dell'hotellerie si è dovuto adeguare, provvedendo a ridisegnare non solo gli spazi comuni con ambienti dedicati, ma anche quelli più privati come le suite e le camere.

Crea il tuo spazio wellness attraverso componenti d'arredo come delle luci soffuse, muri di bolle, e musica rilassante di sottofondo con una tisana calda tra le mani, sdraiati su una chaise lounge, potete abbandonare ogni pensiero e dedicarvi al vostro relax.

## A THOUSAND BLUE BUBBLES

With the emergence of wellness as a lifestyle, the hotel industry has also had to adapt, redesigning not only public areas with dedicated spaces but also more private areas such as suites and rooms.

Create your own wellness space through furnishing components such as soft lighting, walls of bubbles, and relaxing background music with a hot herbal tea in your hands, lying on a chaise lounge, you can abandon all thoughts and devote yourself to your relaxation.















**TERMOIGROMETRO SAUNA**  
SAUNA THERMOHYGROMETER



**MASTELLO E MESTOLO**  
BUCKET AND LADLE



**POGGIATESTA**  
HEADREST



**CLESSIDRA**  
HOURGLASS



**PEDANA IN ABETE**  
FOOTBOARD FIR



**SEDUTA IN AYOUS**  
SITTING IN AYOUS

## SAUNA FINLANDESE + HAMMAM

### RIVESTIMENTO INTERNO



Legno Hemlock "E"

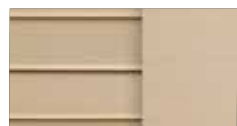

Legno Abete Classic "Z"



Legno Abete Bianco "L"



Legno Abete Nero "T"



Legno Rovere "R"



Legno Olmo "M"



Noce canaletto "Q"

### RIVESTIMENTO ESTERNO IN VETRO



Vetro Retroverniato Bianco "I"



Vetro Opaline



Vetro Retroverniato Nero "V"



Vetro Fumè

### PORTA



Vetro Trasparente "F"

### SEDUTA SAUNA



Legno Ayous

DIMENSIONI SU MISURA	larghezza max. 4151 mm
	profondità max. 1881 mm
	altezza max. 2200 mm
DIMENSIONI STANDARD	3333x1381 mm
	4151x1881 mm
ALTEZZA STANDARD	h. 2200 mm
SPESSORE DEI VETRI	8 mm
MANIGLIA SAUNA	legno/alluminio h. 58 cm
MANIGLIA HAMMAM	alluminio h. 58 cm
ALTEZZA DELLA MANIGLIA	580 mm
ALIMENTAZIONE ELETTRICA SAUNA	220-380V - Specificare prima dell'ordine
ALIMENTAZIONE ELETTRICA HAMMAM	220V Monofase
NUMERO DI PERSONE MAX.	6 (art. 4151x1881)
MATERIALE PANCA	legno Ayous
ILLUMINAZIONE	led (sauna) + rgb (Hammam)
TEMPI DI SPEDIZIONE	5-6 settimane



#### PREDISPOSIZIONE COLLEGAMENTO DOMOTICA:

La **sauna** può essere integrata con sistemi di domotica compatibili, grazie alla scheda elettronica predisposta. Questo permette di gestire l'accensione e lo spegnimento della stufa e dei led direttamente tramite il sistema, offrendo Comfort e praticità avanzati.

#### CARATTERISTICHE/COMPONENTI SAUNA

Stufa elettrica con pietre laviche  
 Centralina digitale professionale con controllo temperatura.  
 Luce a LED retro panca - Cromoterapia a LED.  
 Clessidra con sabbia per durata tempo da 15 minuti.  
 Termoisolamento per controllo temperatura e umidità all'interno della sauna.  
 Mastello e mestolo in legno.  
 Maniglia in legno interno e alluminio esterno con finiture abbinata.  
 Struttura in legno spessore 62 mm con intercapedine termoisolante.  
 Parete esterna della sauna trattato con impregnante.  
 Porta in vetro trasparente temperato da 8 mm di spessore  
 Panche in legno massello atermico di Ayous privo di nodi.  
 Doghe a pavimento in legno calpestabile

#### CARATTERISTICHE/COMPONENTI HAMMAM

Soffione multifunzione dimensione 50x50cm  
 Cromoterapia con stripe led  
 bagno turco di vapore in 3 temperature in sequenza  
 pannello di controllo in vetro con funzioni touch-screen  
 doccia a mano  
 cascata d'acqua  
 nebulizzatori  
 idrogetti verticali n°8  
 coppia casse bluetooth da 50W  
 aromaterapia con essenze  
 piatto doccia compreso

# FINNISH SAUNA + HAMMAM

## INTERNAL COATING



Wood Hemlock "E"



Classic Fir "Z"



Wood Fir White "L"



Wood Fir Black "T"



Oak wood "R"



Elm wood "M"



Canaletto walnut "Q"

## EXTERIOR GLASS COATING

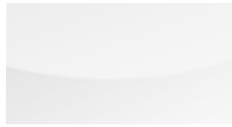

Back-painted glass White "I"



Opaline glass



Back-painted glass Black "V"



Fumè glass

## DOOR



Transparent glass "F"

## SITTING SAUNA



Ayous wood

CUSTOM SIZE	width max. 4151 mm
	depth max. 1881 mm
	height max. 2200 mm
STANDARD DIMENSIONS	3333x1381 mm
	4151x1881 mm
STANDARD HEIGHT	h. 2200 mm
GLASS THICKNESS	8 mm
HANDLE SAUNA	wood/aluminum h. 58 cm
HANDLE HAMMAM	aluminum h. 58 cm
HANDLE HEIGHT	580 mm
POWER SUPPLY SAUNA	220-380V - Specify before the order
POWER SUPPLY HAMMAM	220V Single-phase
NUMBER OF PEOPLE MAX.	6 (art. 4151x1881)
BENCH FINISH	wood Ayous
LIGHTING	led (sauna) + rgb (Hammam)
DELIVERY TIME	5-6 weeks

## FEATURES/COMPONENTS SAUNA

Electric stove with lava stone  
 Professional digital control unit with temperature control.  
 LED light on bench - LED chromotherapy  
 Hourglass with sand for 15 minutes time duration.  
 Thermo-hygrometer for temperature and humidity control inside the sauna.  
 Wooden tub and ladle.  
 Handle made of wood inside and aluminum outside with matching finish.  
 Wooden frame 62 mm thick with rock wool insulation space.  
 An exterior wall of the sauna treated with an impregnating agent.  
 Transparent tempered glass door 8 mm thick  
 Benches made of knotless Ayous solid wood  
 Walk-on wooden floorboards

## FEATURES/COMPONENTS HAMMAM

Multifunctional shower head size 50x50cm  
 Stripe led chromotherapy  
 Turkish steam bath in 3 temperatures in sequence  
 glass control panel with touch-screen functions  
 hand shower  
 waterfall  
 nebulizers  
 8 vertical water jets  
 pair of 50W Bluetooth speakers  
 aromatherapy with essences  
 shower tray included



### HOME AUTOMATION CONNECTION PRE-SETUP:

The **sauna** can be integrated with compatible home automation systems thanks to the preconfigured electrical board. This allows the heater to be turned on and off directly through the system, providing advanced Comfort and convenience.

A silhouette of a person in a yoga pose, likely a variation of the Lotus or Padmasana pose, is shown against a bright, golden sunset background. The person's hands are in the Anjali mudra (prayer position). The sun is low on the horizon, creating a strong lens flare and illuminating the scene with a warm, orange glow. The person's legs are crossed, and their torso is upright. The overall mood is peaceful and serene.

**NIRVANA**

COMBIT  
YOUNG

SAUNA + HAMMAM



## La Sauna e il Bagno turco si differenziano per temperatura e tasso di umidità

entrambi apportano il beneficio del rilassamento, poiché vengono rilasciate endorfine nel cervello che aiutano il benessere, diminuiscono i problemi d'insonnia e aumentano riflessi e concentrazione. Megius S.p.A. ha deciso di non farti mancare nulla, realizzando un prodotto che consente di proporli entrambi in un'unica soluzione!

In questo caso, vi presentiamo la versione Combi 1 Young, più piccola e adattabile a qualsiasi tipo di situazione.

Del progetto Nirvana Combi 1 fa parte anche il modello Young, versione più contenuta in termini di spazio, con dimensioni 2462x1281 mm.

## Sauna and Turkish baths differ in temperature and humidity

both bring the benefit of relaxation since endorphins are released in the brain that help well-being, reduce insomnia problems, and increase reflexes and concentration.

Megius S.p.A. has decided not to miss anything, creating a product that allows you to offer both in one solution!

In this case, we present the Combi 1 Young version, smaller and adaptable to any type of situation.

The Nirvana Combi 1 project also includes the Young model, a smaller version in terms of space, with dimensions of 2462x1281 mm.









#### **IDROGETTI DORSALI REGOLABILI ED ORIENTABILI:**

Le multifunzioni proposte da Megius sono i massaggi realizzati con l'acqua come:  
 massaggio dorsale e cervicale praticato grazie una serie di 8 jets nebulizzati per la zona dorsale e di 4 jets con funzione "cascata" per la zona cervicale, aiutando così ad allentare le tensioni nervose e muscolari.  
 Massaggio verticale che attraverso i jets nebulizzanti effettuano un accurato massaggio che dona energia e modella il corpo.

#### **ADJUSTABLE AND ADJUSTABLE BACK JETS:**

The multi-functions proposed by Megius are massages made with water such as:  
 Back and neck massage, performed using a series of 8 jets for the back area and 4 nebulizing jets for the neck area with a "waterfall" function, helping to relieve nervous and muscular tension.  
 Vertical massage, using nebulizing jets that gently caress and energize the body.





**TERMOIGROMETRO SAUNA**  
SAUNA THERMOHYGROMETER



**MASTELLO E MESTOLO**  
BUCKET AND LADLE



**POGGIATESTA**  
HEADREST



**CLESSIDRA**  
HOURGLASS



**PEDANA IN ABETE**  
FIR FOOTBOARD



**SEDUTA IN AYOUS**  
SITTING IN AYOUS

## SAUNA FINLANDESE + HAMMAM

## RIVESTIMENTO INTERNO



Legno Hemlock "E"



Legno Abete Classic "Z"



Legno Abete Bianco "L"



Legno Abete Nero "T"



Legno Rovere "R"



Legno Olmo "M"



Noce canaletto "Q"

## RIVESTIMENTO ESTERNO IN VETRO



Vetro Retroverniciato Bianco "I"



Vetro Opaline



Vetro Retroverniciato Nero "V"



Vetro Fumè

## PORTA



Vetro Trasparente "F"

## SEDUTA SAUNA



Legno Ayous

DIMENSIONI SU MISURA	larghezza max. 4151 mm profondità max. 1881 mm altezza max. 2200 mm
DIMENSIONI STANDARD	2440x1281 mm
ALTEZZA STANDARD	h. 2200 mm
SPESSORE DEI VETRI	8 mm
MANIGLIA SAUNA	legno/alluminio h. 58 cm
MANIGLIA HAMMAM	alluminio h. 58 cm
ALTEZZA DELLA MANIGLIA	580 mm
ALIMENTAZIONE ELETTRICA SAUNA	220-380V - Specificare prima dell'ordine
ALIMENTAZIONE ELETTRICA HAMMAM	220V Monofase
NUMERO DI PERSONE MAX.	6 (Art. 2440x1281)
MATERIALE PANCA	legno Ayous
ILLUMINAZIONE	led (sauna) + rgb (Hammam)
TEMPI DI SPEDIZIONE	5-6 settimane



## PREDISPOSIZIONE COLLEGAMENTO DOMOTICA:

La **sauna** può essere integrata con sistemi di domotica compatibili, grazie alla scheda elettronica predisposta. Questo permette di gestire l'accensione e lo spegnimento della stufa e dei led direttamente tramite il sistema, offrendo Comfort e praticità avanzati.

## CARATTERISTICHE/COMPONENTI SAUNA

Stufa elettrica con pietre laviche  
Centralina digitale professionale con controllo temperatura.  
Luce a LED retro panca - Cromoterapia a LED.  
Clessidra con sabbia per durata tempo da 15 minuti.  
Termoigrometro per controllo temperatura e umidità all'interno della sauna.  
Mastello e mestolo in legno.  
Maniglia in legno interno e alluminio esterno con finiture abbinata.  
Struttura in legno spessore 62 mm con intercapedine termoisolante.  
Parete esterna della sauna trattato con impregnante.  
Porta in vetro trasparente temperato da 8 mm di spessore  
Panche in legno massello atermico di Ayous privo di nodi.  
Doghe a pavimento in legno calpestabile

## FUNZIONI SAUNA+HAMMAM

Soffione multifunzione dimensione 25x25cm  
cromoterapia RGB  
bagno turco di vapore in 3 temperature in sequenza  
pannello di controllo in vetro con funzioni touch-screen  
doccia a mano  
cascata d'acqua  
nebulizzatori  
idrogetti verticali n°8  
coppia casse bluetooth da 50W  
aromoterapia con essenze  
piatto doccia compreso

## OPTIONAL HAMMAM

Sgabello (vedi pag. 218)

## FINNISH SAUNA + HAMMAM

### INTERNAL COATING



Wood Hemlock "E"



Classic Fir "Z"



Wood Fir White "L"

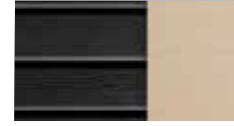

Wood Fir Black "T"



Oak wood "R"



Elm wood "M"



Canaletto walnut "Q"

### EXTERIOR GLASS COATING

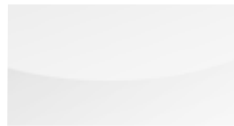

Back-painted glass White "I"



Opaline glass



Back-painted glass Black "V"



Fumè glass

### DOOR



Transparent glass "F"

### SITTING SAUNA



Ayous wood

CUSTOM SIZE	width max. 4151 mm depth max. 1881 mm height max. 2200 mm
STANDARD DIMENSIONS	2440x1281 mm
STANDARD HEIGHT	h. 2200 mm
GLASS THICKNESS	8 mm
HANDLE SAUNA	wood/aluminum h. 58 cm
HANDLE HAMMAM	aluminum h. 58 cm
HANDLE HEIGHT	580 mm
POWER SUPPLY SAUNA	220-380V - Specify before the order
POWER SUPPLY HAMMAM	220V Single-phase
NUMBER OF PEOPLE MAX.	6 (Art. 2440x1281)
BENCH FINISH	wood Ayous
LIGHTING	led (sauna) + rgb (Hammam)
DELIVERY TIME	5-6 weeks



#### HOME AUTOMATION CONNECTION PRE-SETUP:

The **sauna** can be integrated with compatible home automation systems thanks to the preconfigured electrical board. This allows the heater to be turned on and off directly through the system, providing advanced Comfort and convenience.

### FEATURES/COMPONENTS SAUNA

Electric stove with lava stone  
Professional digital control unit with temperature control.  
LED light on bench - LED chromotherapy.  
Hourglass with sand for 15 minutes time duration.  
Thermo-hygrometer for temperature and humidity control inside the sauna.  
Wooden tub and ladle.  
Handle made of wood inside and aluminum outside with matching finish.  
Wooden frame 62 mm thick with rock wool insulation space.  
An exterior wall of the sauna treated with an impregnating agent.  
Transparent tempered glass door 8 mm thick  
Benches made of knotless Ayous solid wood  
Walk-on wooden floorboards

### FEATURES/COMPONENTS HAMMAM

Multifunctional shower head size 25x25cm  
RGB chromotherapy  
Turkish steam bath in 3 temperatures in sequence  
glass control panel with touch-screen functions  
hand shower  
waterfall  
nebulizers  
8 vertical water jets  
pair of 50W Bluetooth speakers  
aromatherapy with essences  
shower tray included

### OPTIONAL HAMMAM

Stool (see page 218)

A stack of four dark, smooth, rounded stones is positioned on the left side of the image. The stones are stacked vertically, with the top one being the smallest and the bottom one being the largest. The background is a solid, light blue color. The text is overlaid on the right side of the image.

ZEN  
COMBI DUO  
CORNER/LINEAR

SAUNA + HAMMAM



ZEN COMBI  
DUO CORNER  
SAUNA + HAMMAM

Zen Combi: una soluzione benessere compatta e completa per l'ambiente domestico o l'hospitality.

In questa proposta firmata Megius si fonde l'essenza del calore e del vapore in un unico corpo visivamente armonico, dove sauna e bagno turco convivono con eleganza in configurazione lineare.

Il vetro frontale, privo di profili di giunzione, valorizza la pulizia delle linee e regala trasparenza all'insieme, mentre la colonna centrale ospita un touch display per il controllo della sauna, del bagno turco e della cromoterapia.

Le superfici esterne opache sono rivestite in materiali tecnici di colore bianco o nero, perfetti per ambienti moderni.

Disponibile in tre misure (200x100 cm, 240x120 cm e 290x120 cm), Zen Combi Linear è la soluzione ideale per chi desidera una minispa funzionale e personalizzabile, anche in spazi contenuti.



ZEN COMBI  
DUO LINEAR  
SAUNA + HAMMAM

Zen Combi: a compact and complete wellness solution for the home or hospitality settings.

In this Megius creation, heat and steam come together in a single harmonious unit, where sauna and steam bath elegantly coexist in a linear configuration.

The front glass, free of visible junction profiles, enhances the clean lines and offers a transparent, open feel, while the central column houses a touch display to control the sauna, steam generator, and chromotherapy in both modules.

The outer opaque surfaces are finished in modern white or black technical materials, ideal for contemporary interiors.

Available in three sizes (200x100 cm, 240x120 cm, and 290x120 cm), Zen Combi Linear is the ideal solution for those seeking a functional, customizable mini-spa—even in limited spaces.

A close-up photograph of several smooth, dark volcanic stones resting on a light-colored, reflective surface. The stones are arranged in a line, with the one in the foreground being the most prominent and in sharp focus. The background is softly blurred, showing more stones and a bright, overexposed area. The overall mood is serene and minimalist.

ZEN  
COMBI DUO  
CORNER  
SAUNA + HAMMAM



Zen Combi Corner: la versione ad angolo che unisce design, funzionalità e benessere. Pensata per ambienti domestici o suite d'hotel che desiderano distinguersi, Zen Combi Corner combina sauna e bagno turco in una configurazione ad angolo, compatta ma completa.

I due moduli sono stilisticamente coordinati, con finiture in legno impiallacciato (come abete, cedro o noce canaletto) per la sauna e componenti tecnici evoluti nella zona bagno turco, che include soffione, cascata cervicale, idrogetti e doccia a mano. Il vetro angolare senza profili dona leggerezza visiva, mentre la colonna centrale integra tutti i comandi digitali. Disponibile in due dimensioni (250x180 cm e 290x210 cm), è una vera oasi privata che si adatta con eleganza anche a contesti contract, grazie alle possibilità di personalizzazione su misura.

Zen Combi Corner: the corner version that combines design, functionality, and well-being. Designed for home environments or hotel suites that aim to stand out, Zen Combi Corner combines a sauna and a steam bath in a smart, space-saving corner layout.

The two wellness modules are stylistically aligned, with veneered wood finishes available for the sauna (such as spruce, cedar, or walnut) and advanced features in the steam area, including overhead shower, cervical waterfall, hydrojets, and hand shower, all managed via a modern button diverter. The frameless corner glass adds visual lightness, while the central column integrates all digital controls. Offered in two dimensions (250x180 cm and 290x210 cm), it is a true private oasis that adapts beautifully to both residential and contract settings, with custom sizing available to suit specific needs.













# SCHEDA TECNICA ZEN COMBI

## SAUNA + HAMMAM

### FINITURA VETRO



Vetro Trasparente "E"

### FINITURE PROFILI



Alluminio Bianco Opaco "E"



Alluminio Nero "Z"

### RIVESTIMENTO INTERNO



Legno Hemlock "E"



Abete Classic "Z"



Noce canaletto "E"

### SEDUTA SAUNA



Legno Ayous

### SEDUTA HAMMAM



Legno Frassino termotrattato

### RIVESTIMENTO E ANTA TECNICA



Bianco "E"

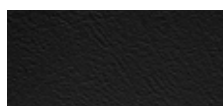

Nero "Z"

### ALLESTIMENTI



Rubinetteria in finitura nero opaco



### PREDISPOSIZIONE COLLEGAMENTO DOMOTICA:

La **sauna** e **hammam** possono essere integrata con sistemi di domotica compatibili, grazie alla scheda elettronica predisposta. Questo permette di gestire l'accensione e lo spegnimento della stufa e dei led direttamente tramite il sistema, offrendo Comfort e praticità avanzati.

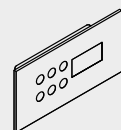

Il nuovo Touch display permette di combinare e gestire le diverse funzioni tra sauna e hammam in modo sinergico tra prodotti oltre a gestire l'accensione e spegnimento delle luci all'interno. Disponibile in due colori: bianco e nero.

DIMENSIONI SU MISURA	larghezza max. 4151 mm
	profondità max. 1881 mm
	altezza max. 2200 mm
DIMENSIONI STANDARD	2540x1805 mm
	2940x2055 mm
ALTEZZA STANDARD	h. 2140mm
SPESSORE DEI VETRI	6 mm HAMMAM - 8 mm SAUNA
MANIGLIA SAUNA	legno/alluminio h. 580 mm
MANIGLIA DOCCIA	alluminio h. 580 mm
ALIMENTAZIONE ELETTRICA SAUNA	220-380V - Specificare prima dell'ordine
ALIMENTAZIONE ELETTRICA HAMMAM	220V Monofase
ILLUMINAZIONE	Strip Led RGB HAMMAM/SAUNA
TRATTAMENTO PROTECTIVE	incluso
PIATTO DOCCIA HAMMAM	incluso
SEDUTA HAMMAM	incluso
SEDUTA SAUNA	incluso
MENSOLE IN LEGNO	n°6 incluse
TEMPI DI SPEDIZIONE	5-6 settimane

### CARATTERISTICHE/COMPONENTI HAMMAM

soffione incassato dimensione 20x20cm  
3 idrogetti dorsali  
cascata d'acqua  
doccia a mano  
miscelatore termostatico  
deviatore meccanico a 4 vie  
anta tecnica ispezionabile  
generatore di vapore  
PANCA INCLUSA e mensole in legno Iroko  
cromoterapia con n°1 Strip Led a soffitto

### CARATTERISTICHE/COMPONENTI SAUNA

Stufa elettrica con pietre laviche, con accensione a comando integrato  
Luce a LED retro panca - Cromoterapia a LED.  
Clessidra con sabbia per durata tempo da 15 minuti.  
Termoigrometro per controllo temperatura e umidità all'interno della sauna.  
Mastello e mestolo in legno.  
Sistema di apertura con porta BATTENTE  
Pedana in legno removibile

# TECHNICAL FEATURES ZEN COMBI

## SAUNA + HAMMAM

### GLASS FINISH



Transparent tempered glass "F"

### PROFILE FINISHES



Matt White Aluminum "E"

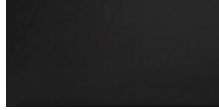

Matt Black Aluminum "Z"

### INTERNAL COATING



Wood Hemlock "E"



Classic Fir "Z"



Canaletto walnut "E"

### SITTING SAUNA



Ayous wood

### SITTING HAMMAM



Wood Ash heat treated

### COVER AND TECHNICAL DOOR



White "E"



Black "Z"

### EQUIPMENTS



Taps in matt black finish



### HOME AUTOMATION CONNECTION PRE-SETUP:

The **sauna y hammam** can be integrated with compatible home automation systems, thanks to the pre-configured electronic board. This allows you to control the heater's on and off functions directly through the system, offering advanced comfort and convenience.

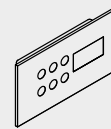

The new Touch Display allows you to combine and manage the various functions between sauna and hammam synergistically across products, as well as control the turning on and off of interior lights. Available in two colors: white and black.

CUSTOM SIZE	width max. 4151 mm
	depth max. 1881 mm
	height max. 2200 mm
STANDARD DIMENSIONS	2540x1805 mm
	2940x2055 mm
STANDARD HEIGHT	h. 2140mm
GLASS THICKNESS	6 mm HAMMAM - 8 mm SAUNA
HANDLE SAUNA	wood/aluminum h. 580 mm
HANDLE SHOWER ENCLOSURES	aluminum h. 580 mm
POWER SUPPLY SAUNA	220-380V - Specify before the order
POWER SUPPLY HAMMAM	220V Single-phase
LIGHTING	Strip Led RGB HAMMAM/SAUNA
PROTECTIVE TREATMENT	included
SHOWER TRAY HAMMAM	included
SITTING HAMMAM	included
SITTING SAUNA	included
WOODEN SHELVES	n°6 included
DELIVERY TIME	5-6 weeks

### FEATURES/COMPONENTS HAMMAM

built-in shower head size 25x25cm  
3 back jets  
waterfall  
hand shower  
thermostatic mixer  
4-way mechanical diverter  
inspectional technical door  
steam generator  
seat and shelves in Iroko wood  
chromotherapy with n°1 LED strip on the ceiling

### SAUNA FEATURES/COMPONENTS

Electric stove with lava stone, with integrated control ignition  
LED light on bench - LED chromotherapy.  
Hourglass with sand for 15 minutes time duration.  
Thermo-hygrometer for monitoring temperature and humidity inside the sauna.  
Wooden tub and ladle.  
Opening system with HINGED door  
Removable wooden floor slats

The background of the advertisement is a serene, high-angle photograph of a beach at low tide. Three smooth, dark, rounded stones are arranged in a horizontal line across the middle of the frame. The wet sand is highly reflective, creating clear, mirror-like reflections of the stones and the sky. The sky is a pale, hazy blue, and the overall lighting is soft and natural, suggesting a calm, peaceful atmosphere. The text is overlaid in the center, with 'ZEN' in a bold, white, sans-serif font at the top. Below it, 'COMBI DUO' is written in a thin, white, outlined sans-serif font. Underneath that, 'LINEAR' is in a very bold, white, sans-serif font. At the bottom of the text block, 'SAUNA + HAMMAM' is written in a smaller, white, sans-serif font.

ZEN  
COMBI DUO  
LINEAR  
SAUNA + HAMMAM



ZEN Combi in questa soluzione per il relax targata Megius possiamo ammirare l'esaltazione del binomio tra calore-acqua.

Esternamente si percepisce come un corpo unico, stilisticamente coordinato nei dettagli, anche se a ben guardare si tratta di 2 anime del benessere: Infatti Zen Combi combina una doccia con bagno turco con panca e ripiani in legno e una sauna con ingresso ad angolo: tutte le superfici sono simili in entrambe le parti; una sorta di minispasche può essere tranquillamente collocata in un ambiente domestico

ZEN Combi in this Megius relaxation solution we can admire the exaltation of the heat-water combination.

Exteriorly it is perceived as a single body, stylistically coordinated in detail, although on closer inspection it is two wellness souls: So, Zen Combi combines a shower and steam bath with wooden bench and shelves and a sauna with a corner entrance: all surfaces are similar on both sides; a kind of mini-spa can easily be placed in a home environment





















# SCHEDA TECNICA ZEN COMBI

## SAUNA + HAMMAM

### FINITURA VETRO



Vetro Trasparente "E"

### FINITURE PROFILI



Alluminio Bianco Opaco "E"



Alluminio Nero "Z"

### RIVESTIMENTO INTERNO



Legno Hemlock "E"



Abete Classic "Z"



Noce canaletto "E"

### SEDUTA SAUNA



Legno Ayous

### SEDUTA HAMMAM



Legno Frassino termotrattato

### RIVESTIMENTO E ANTA TECNICA



Bianco "E"

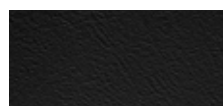

Nero "Z"

### ALLESTIMENTI



Rubinetteria in finitura nero opaco



### PREDISPOSIZIONE COLLEGAMENTO DOMOTICA:

La **sauna** e **hammam** possono essere integrata con sistemi di domotica compatibili, grazie alla scheda elettronica predisposta. Questo permette di gestire l'accensione e lo spegnimento della stufa e dei led direttamente tramite il sistema, offrendo Comfort e praticità avanzati.

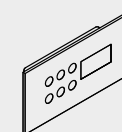

Il nuovo Touch display permette di combinare e gestire le diverse funzioni tra sauna e hammam in modo sinergico tra prodotti oltre a gestire l'accensione e spegnimento delle luci all'interno. Disponibile in due colori: bianco e nero.

DIMENSIONI SU MISURA	larghezza max. 2900 mm
	profondità max. 1200 mm
	altezza max. 2142 mm
DIMENSIONI STANDARD	2000x1000 mm
	2400x1200 mm
	2900x1200 mm
ALTEZZA STANDARD	h. 2.142 mm
SPESSORE DEI VETRI	6/8 mm HAMMAM - 8 mm SAUNA
MANIGLIA SAUNA	legno/alluminio h. 580 mm
MANIGLIA HAMMAM	alluminio h. 580 mm
ALIMENTAZIONE ELETTRICA SAUNA	220-380V - Specificare prima dell'ordine
ALIMENTAZIONE ELETTRICA HAMMAM	220V Monofase
ILLUMINAZIONE	Strip Led RGB
TRATTAMENTO PROTECTIVE	incluso
PIATTO DOCCIA HAMMAM	incluso
SEDUTA HAMMAM	incluso
SEDUTA SAUNA	incluso
MENSOLE IN LEGNO	n°1/6 incluse
TEMPI DI SPEDIZIONE	5-6 settimane

### CARATTERISTICHE/COMPONENTI HAMMAM

soffione incassato dimensione 20x20cm  
3 idrogetti dorsali  
cascata d'acqua  
doccia a mano  
miscelatore termostatico  
deviatore meccanico a 4 vie  
anta tecnica ispezionabile  
generatore di vapore  
PANCA INCLUSA (dove indicato) + mensole in Legno Frassino termotrattato  
cromoterapia con n°1 Strip Led a soffitto

### CARATTERISTICHE/COMPONENTI SAUNA

Stufa elettrica con pietre laviche, con accensione a comando integrato  
Luce a LED retro panca  
Clessidra con sabbia per durata tempo da 15 minuti.  
Termoigrometro per controllo temperatura e umidità all'interno della sauna.  
Mastello e mestolo in legno.  
Sistema di apertura con porta BATTENTE  
Pedana in legno removibile

# TECHNICAL FEATURES ZEN COMBI

## SAUNA + HAMMAM

### GLASS FINISH



Transparent tempered glass "F"

### PROFILE FINISHES



Matt White Aluminum "E"

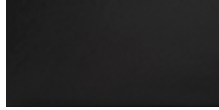

Matt Black Aluminum "Z"

### INTERNAL COATING



Wood Hemlock "E"



Classic Fir "Z"



Canaletto walnut "E"

### SITTING SAUNA



Ayous wood

### SITTING HAMMAM



Wood Ash heat treated

### COVER AND TECHNICAL DOOR



White "E"



Black "Z"

### EQUIPMENTS



Taps in matt black finish



### HOME AUTOMATION CONNECTION PRE-SETUP:

The **sauna y hammam** can be integrated with compatible home automation systems, thanks to the pre-configured electronic board. This allows you to control the heater's on and off functions directly through the system, offering advanced comfort and convenience.

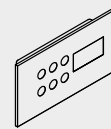

The new Touch Display allows you to combine and manage the various functions between sauna and hammam synergistically across products, as well as control the turning on and off of interior lights. Available in two colors: white and black.

CUSTOM SIZE	width max. 2900 mm
	depth max. 1200 mm
	height max. 2142 mm
STANDARD DIMENSIONS	2000x1000 mm
	2400x1200 mm
	2900x1200 mm
STANDARD HEIGHT	h. 2142 mm
GLASS THICKNESS	6/8 mm HAMMAM - 8 mm SAUNA
HANDLE SAUNA	wood/aluminum h. 580 mm
HANDLE HAMMAM	aluminum h. 580 mm
POWER SUPPLY SAUNA	220-380V - Specify before the order
POWER SUPPLY HAMMAM	220V Single-phase
LIGHTING	Strip Led RGB
PROTECTIVE TREATMENT	included
SHOWER TRAY HAMMAM	included
SITTING HAMMAM	included
SITTING SAUNA	included
WOODEN SHELVES	n°/6 included
DELIVERY TIME	5-6 weeks

### FEATURES/COMPONENTS HAMMAM

built-in shower head size 25x25cm  
3 back jets  
waterfall  
hand shower  
thermostatic mixer  
4-way mechanical diverter  
inspectional technical door  
steam generator  
seat and shelves in Wood Ash heat treated  
chromotherapy with n°1 LED strip on the ceiling

### SAUNA FEATURES/COMPONENTS

Electric stove with lava stone, with integrated control ignition  
LED light under the bench  
Hourglass with sand for 15 minutes time duration.  
Thermo-hygrometer for monitoring temperature and humidity inside the sauna.  
Wooden tub and ladle.  
Opening system with HINGED door  
Removable wooden floor slats

A serene sunset scene over a calm ocean. The sun is low on the horizon, creating a bright, shimmering reflection on the water's surface. The sky transitions from a pale yellow near the horizon to a soft, hazy blue at the top. In the foreground, a dark, sandy beach curves along the water's edge, with gentle waves lapping at the shore.

**WELLBOX**

HAMMAM

PIVOT / SLIDING



Fare innovazione su una cabina hammam ad anta battente è sicuramente una sfida impegnativa.

Una delle prerogative di questo multifunzione è la possibilità di essere installato in centro stanza. Grazie alla minuziosa progettazione e alla cura dei dettagli e dei materiali, infatti, il retro dell'anta tecnica a richiesta è corredato di lastra in cristallo retroverniciata: esaltazione dell'eleganza e della raffinatezza del prodotto.

Innovating a hinged door hammam cabin is certainly a challenge.

One of the prerogatives of this multifunctional shower enclosure is that it can be installed in the middle of the room. Thanks to the meticulous design and attention to detail and materials, the back of the technical door is fitted with a back-painted glass panel: enhancing the elegance and refinement of the product.





## ACQUA, VAPORE, MUSICA, COLORI, PROFUMI

il carattere naturale del piacere. Le nuove tecnologie, abbinate alla ricerca del benessere e rigenerazione quotidiana trovano in queste soluzioni tutto ciò che serve a far sì che il corpo si rigeneri dallo stress, riacquisti la forma desiderata e ritorni nella sua naturale serenità

## WATER, STEAM, MUSIC, COLOURS, SCENTS

the natural character of pleasure. The new technologies, combined with the search for well-being and daily regeneration, find in these solutions everything they need to help the body regenerate from stress, regain the desired shape and return to its natural serenity









# IMMERGITI NEL RELAX

Tutti i benefici del bagno di vapore si uniscono alla più avanzata tecnologia:

Trasforma la tua doccia in un vero e proprio hammam: grazie le temperature più basse si possono prolungare le sessioni all'interno dell'hammam stesso, che sono un vero toccasana per le vie respiratorie oppure scegli tra la gamma di sistemi Megius pronti per essere installati o realizzati su misura.

# IMMERSE YOURSELF IN RELAXATION

All the benefits of the steam bath are combined with state of the art technology:

Turn your shower into a real hammam: thanks to the lower temperatures you can prolong the sessions inside the hammam itself, which are a real panacea for the respiratory tract or choose from the range of Megius systems ready to be installed or custom-made.



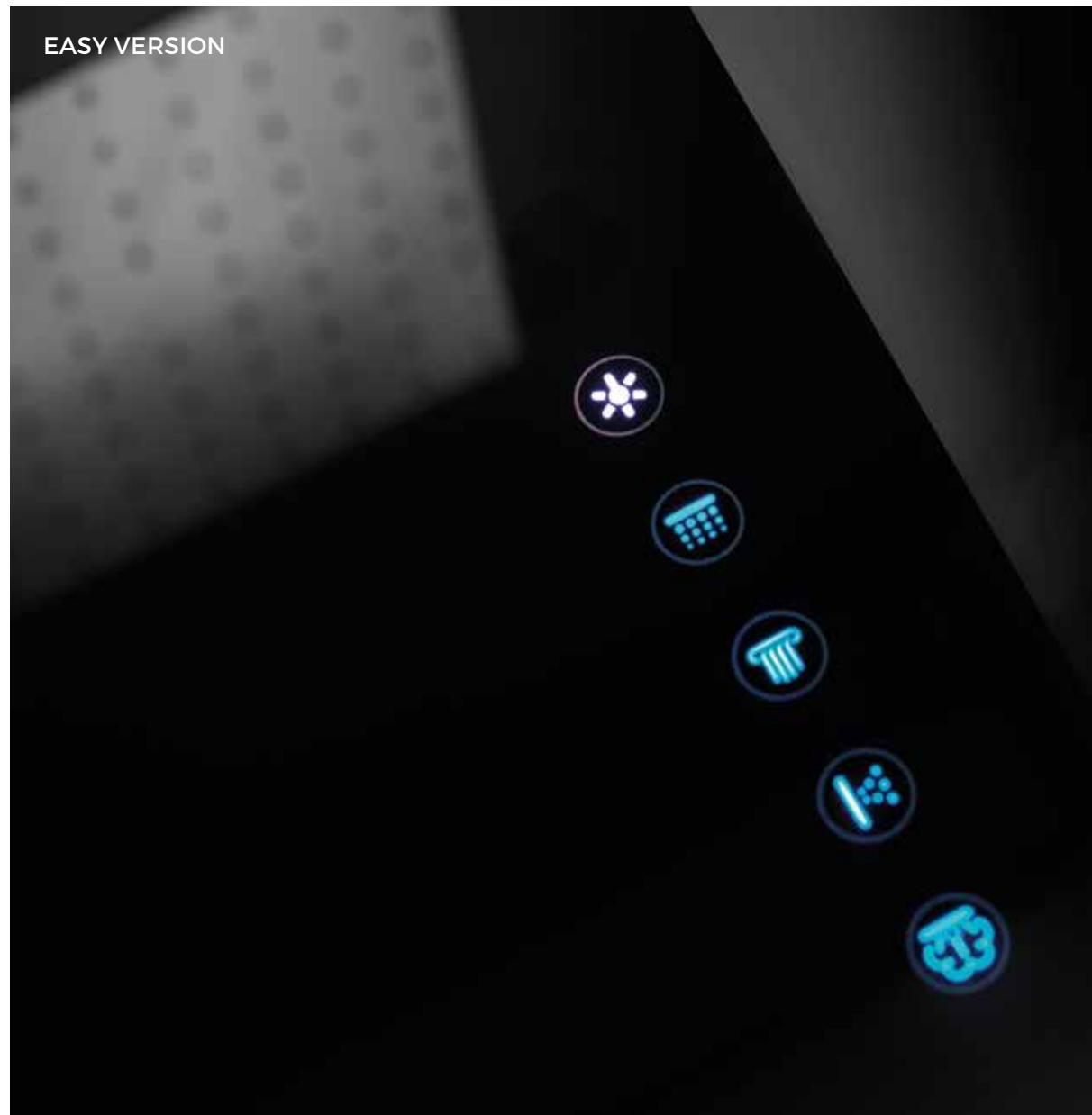

## TASTIERA TOUCH

La tastiera è composta da cinque pulsanti adibiti al controllo di: on/off faro, soffioni, cascata, getti dorsali e bagno vapore.

Nella sua rinnovata versione Well Box si evolve in 3 tipologie di ante tecniche (Easy, Top e Premium) entrambe rigorosamente touch-screen e studiate per incontrare le più esigenti richieste della nostra clientela, ogni anta tecnica presenta anche un deviatore per gestire l'accensione e lo spegnimento dell'acqua più il doccino a mano.

## TOUCH KEYBOARD

The keypad consists of five buttons used to control: RGB color therapy, hand shower, ventilation heating, steam bath.

In its renewed version, Well Box evolves into 3 types of doors all rigorously modern, sophisticated, and TOUCH, to meet the most demanding the most demanding requirements of our customers.











# NUVOLA DI COLORI E VAPORE

· LASCIARSI AVVOLGERE DA UNA NUVOLA DI VAPORE SATURA DI AROMI E FRESCHE FRAGRANZE

· LASCIARSI STIMOLARE DA GETTI IDROMASSAGGIO E CICLI DI LUCI ENERGIZZANTI;

· LASCIARSI TRASPORTARE DALLA MUSICA IN MAGICHE ATMOSFERE PERMETTE AI SENSI DI RIACQUISTARE L'EQUILIBRIO BIO-DINAMICO. (PREMIUM VERSION)

# CLOUD OF COLOURS AND STEAM

· LET YOURSELF BE ENVELOPED IN A CLOUD OF STEAM SATURATED WITH AROMAS AND FRESH FRAGRANCES

· LET YOURSELF BE STIMULATED BY HYDROMASSAGE JETS AND CYCLES OF ENERGIZING LIGHTS;

· LET YOURSELF BE CARRIED AWAY BY MUSIC IN MAGICAL ATMOSPHERES, ALLOWING YOUR SENSES TO REGAIN THEIR BIO-DYNAMIC BALANCE. (PREMIUM VERSION)

WELLBOX

# EASY PIVOT



FUNZIONI
EASY TOUCH
soffione multifunzione 25x25 cm ABS - cromato
faro luce bianca
bagno turco / hammam
idrogetti dorsali N°8
touch display
cascata d'acqua
doccino a mano

## CARATTERISTICHE/COMPONENTI

Miscelatore Termostatico  
 Doccino Stylo con getti in gomma silconica Easy Clean (gestita tramite rubinetto apri/chiedi e miscelatore)  
 Sgabello 1 pz.  
 Porta essenze per aromaterapia  
**REVERSIBILE**

FUNCTIONS
EASY TOUCH
multifunctional shower head 25x25 cm ABS - chromed
White light spotlight
turkish steam bath / hammam
back water jets N°8
touch-screen keyboard
blade of water
hand shower

## COMPONENTS AND ACCESSORIES INCLUDED

Thermostatic mixer  
 Stylo magnetic hand shower with Easy Clean silicone rubber jets (operated by opening/closing tap and mixer)  
 Stool 1 pz.  
 Aromatherapy essence holder  
**REVERSIBLE**

**1257x900**

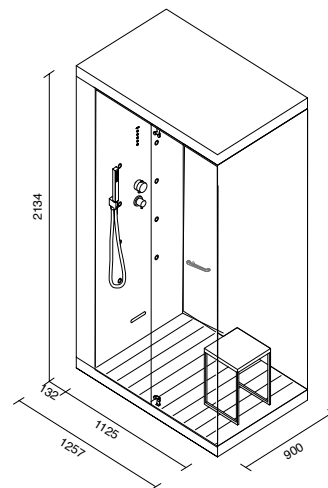

**1557x900**

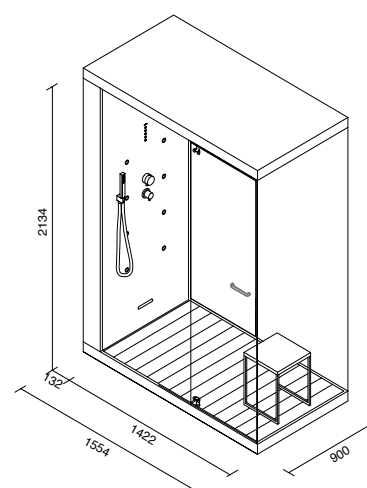

# WELLBOX SINGLE PIVOT/SLIDING



FUNZIONI		
IDRO	TOP	PREMIUM
soffione 25x25 cm	soffione 25x25 cm	soffione 50x50 cm
-	faro luce RGB	2 Strip Led rgb
-	bagno turco / hammam	bagno turco / hammam
idrogetti dorsali N°8	idrogetti dorsali N°8	idrogetti dorsali N°8
-	-	Coppia casse 50W + bluetooth
-	touch display	touch display
casata d'acqua	casata d'acqua	casata d'acqua
doccino a mano	doccino a mano	doccino a mano
-	-	nebulizzatori

## CARATTERISTICHE/COMPONENTI

Miscelatore Termostatico  
Doccino Stylo con getti in gomma siliconica Easy Clean (rubinetto apri/  
chiudi e miscelatore)  
Sgabello 1 pz.

FUNZIONI		
IDRO	TOP	PREMIUM
shower head 25x25 cm	shower head 25x25 cm	shower head 50x50 cm
-	RGB light	2 Strip Led RGB
-	turkish steam bath / hammam	turkish steam bath / hammam
back water jets N°8	back water jets N°8	back water jets N°8
-	-	Pair of 50W speakers + bluetooth
-	touch-screen keyboard	touch-screen keyboard
blade of water	blade of water	blade of water
hand shower	hand shower	hand shower
-	-	nebulizers

## COMPONENTS AND ACCESSORIES INCLUDED

Thermostatic mixer  
Stylo magnetic hand shower with Easy Clean silicone rubber jets (opening/  
closing tap and mixer)  
Stool 1 pz.  
Aromatherapy essence holder

1257x900

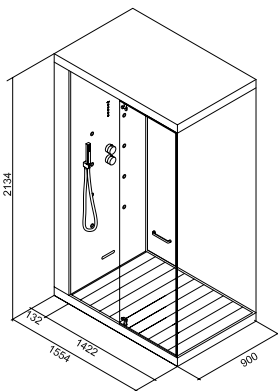

1554x900

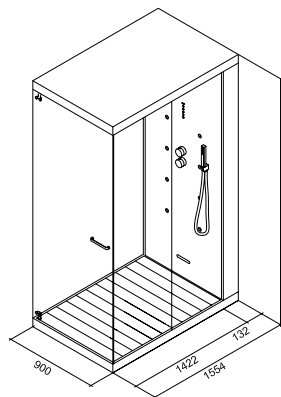

1950x900

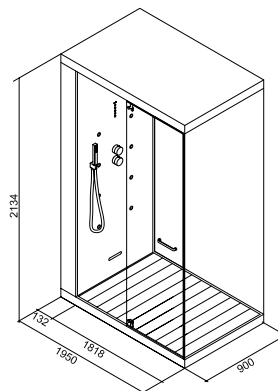

1257x900

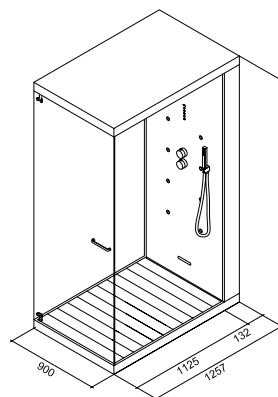

1653x900

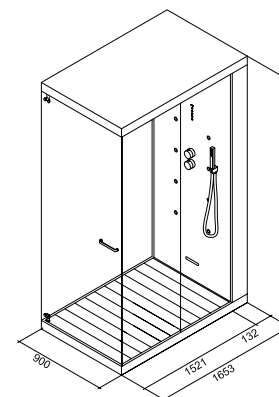

1950x900

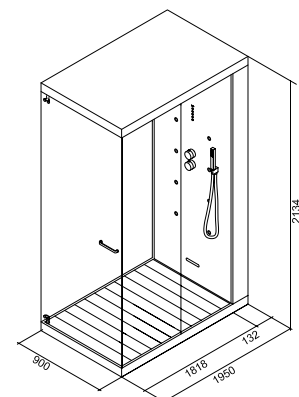

## DOUBLE PIVOT/SLIDING



FUNZIONI		
IDRO	TOP	PREMIUM
soffione 25x25 cm	soffione 25x25 cm	soffione 50x50 cm
-	faro luce RGB	2 Strip Led rgb
-	bagno turco / hammam	bagno turco / hammam
idrogetti dorsali N°8	idrogetti dorsali N°8	idrogetti dorsali N°8
-	-	Coppia casse 50W + bluetooth
-	touch display	touch display
cascata d'acqua	cascata d'acqua	cascata d'acqua
doccino a mano	doccino a mano	doccino a mano
-	-	nebulizzatori

## CARATTERISTICHE/COMPONENTI

Miscelatore Termostatico  
 Doccino Stylo con getti in gomma siliconica Easy Clean (rubinetto apri/  
 chiudi e miscelatore)  
 Sgabello 1 pz.

FUNZIONI		
IDRO	TOP	PREMIUM
shower head 25x25 cm	shower head 25x25 cm	shower head 50x50 cm
-	RGB light	2 Strip Led RGB
-	turkish steam bath / hammam	turkish steam bath / hammam
back water jets N°8	back water jets N°8	back water jets N°8
-	-	Pair of 50W speakers + bluetooth
-	touch-screen keyboard	touch-screen keyboard
blade of water	blade of water	blade of water
hand shower	hand shower	hand shower
-	-	nebulizers

## COMPONENTS AND ACCESSORIES INCLUDED

Thermostatic mixer  
 Stylo magnetic hand shower with Easy Clean silicone rubber jets (opening/  
 closing tap and mixer)  
 Stool 1 pz.  
 Aromatherapy essence holder

1686x850

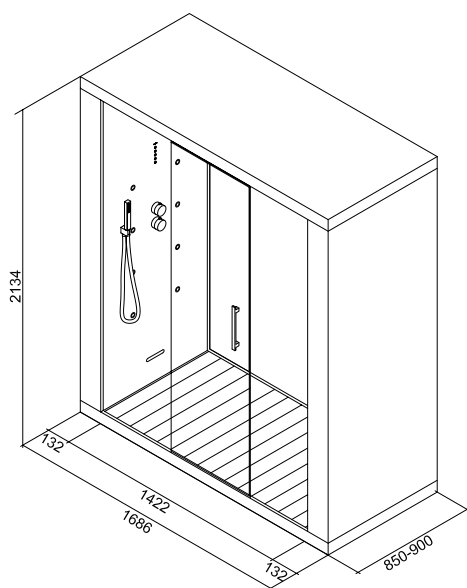

2280x850

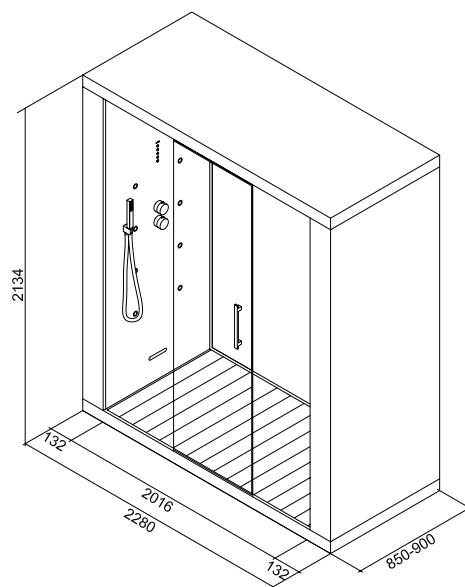

1686x900

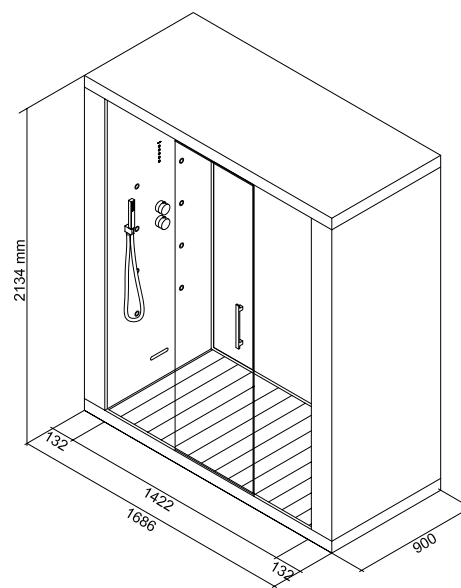

2280x900

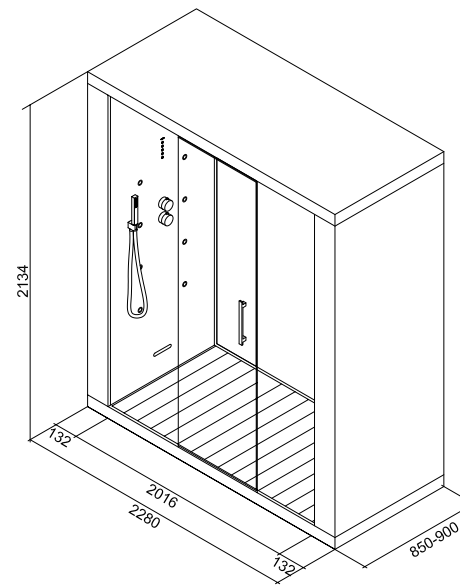

WELLBOX

## WIDE PIVOT/SLIDING



FUNZIONI		
IDRO	TOP	PREMIUM
soffione 25x25 cm	soffione 25x25 cm	soffione 50x50 cm
-	faro luce RGB	2 Strip Led rgb
-	bagno turco / hammam	bagno turco / hammam
idrogetti dorsali N°8	idrogetti dorsali N°8	idrogetti dorsali N°8
-	-	Coppia casse 50W + bluetooth
-	touch display	touch display
cascata d'acqua	cascata d'acqua	cascata d'acqua
doccino a mano	doccino a mano	doccino a mano
-	-	nebulizzatori

## CARATTERISTICHE/COMPONENTI

Miscelatore Termostatico  
 Doccino Stylo con getti in gomma siliconica Easy Clean (rubinetto apri/  
 chiudi e miscelatore)  
 Sgabello 1 pz.

FUNZIONI		
IDRO	TOP	PREMIUM
shower head 25x25 cm	shower head 25x25 cm	shower head 50x50 cm
-	RGB light	2 Strip Led RGB
-	turkish steam bath / hammam	turkish steam bath / hammam
back water jets N°8	back water jets N°8	back water jets N°8
-	-	Pair of 50W speakers + bluetooth
-	touch-screen keyboard	touch-screen keyboard
blade of water	blade of water	blade of water
hand shower	hand shower	hand shower
-	-	nebulizers

## COMPONENTS AND ACCESSORIES INCLUDED

Thermostatic mixer  
 Stylo magnetic hand shower with Easy Clean silicone rubber jets (opening/  
 closing tap and mixer)  
 Stool 1 pz.  
 Aromatherapy essence holder

1686x900-1032

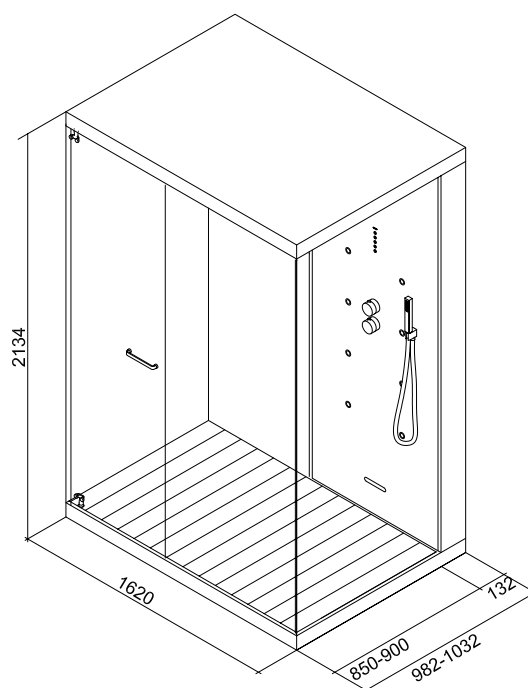

1818x900-1032

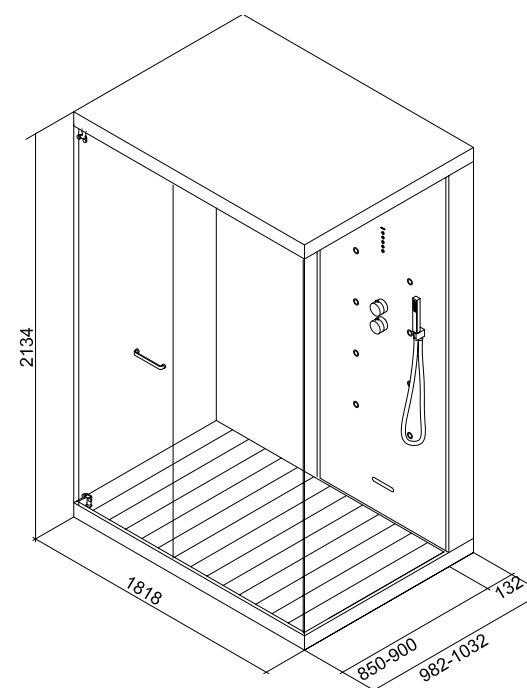

# WELLBOX LARGE PIVOT



FUNZIONI		
IDRO	TOP	PREMIUM
soffione 25x25 cm	soffione 25x25 cm	soffione 50x50 cm
-	faro luce RGB	2 Strip Led rgb
-	bagno turco / hammam	bagno turco / hammam
idrogetti dorsali N°8	idrogetti dorsali N°8	idrogetti dorsali N°8
-	-	Coppia casse 50W + bluetooth
-	touch display	touch display
cascata d'acqua	cascata d'acqua	cascata d'acqua
doccino a mano	doccino a mano	doccino a mano
-	-	nebulizzatori

## CARATTERISTICHE/COMPONENTI

Miscelatore Termostatico  
Doccino Stylo con getti in gomma silconica Easy Clean (rubinetto apri/  
chiudi e miscelatore)  
Sgabello 1 pz.

FUNZIONI		
IDRO	TOP	PREMIUM
shower head 25x25 cm	shower head 25x25 cm	shower head 50x50 cm
-	RGB light	2 Strip Led RGB
-	turkish steam bath / hammam	turkish steam bath / hammam
back water jets N°8	back water jets N°8	back water jets N°8
-	-	Pair of 50W speakers + bluetooth
-	touch-screen keyboard	touch-screen keyboard
blade of water	blade of water	blade of water
hand shower	hand shower	hand shower
-	-	nebulizers

## COMPONENTS AND ACCESSORIES INCLUDED

Thermostatic mixer  
Stylo magnetic hand shower with Easy Clean silicone rubber jets (opening/  
closing tap and mixer)  
Stool 1 pz.  
Aromatherapy essence holder

1620x1381

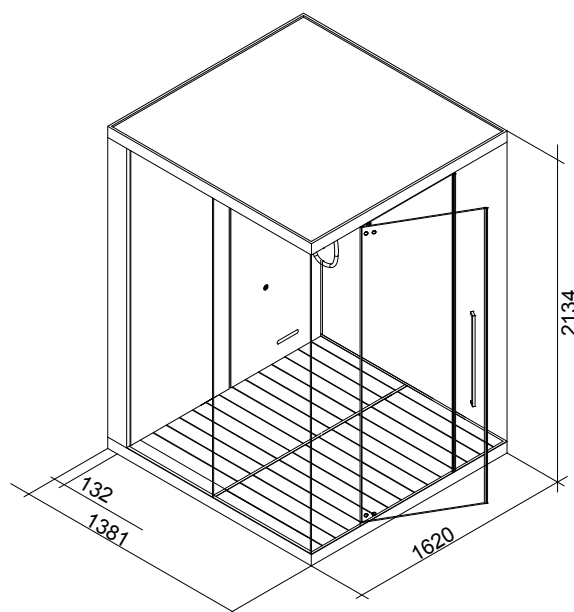

1818x1381

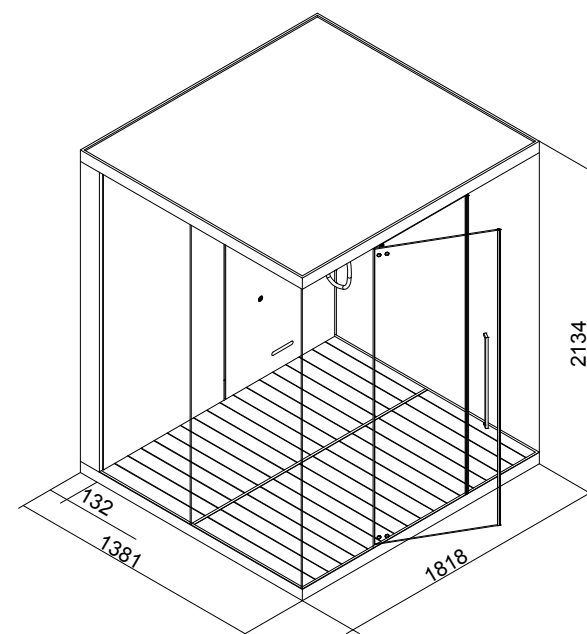

# SCHEDA TECNICA

## WELLBOX HAMMAM

DIMENSIONI <b>EASY</b> / DIMENSION <b>EASY</b>	1257x900 mm
	1554x900 mm
DIMENSIONI <b>SINGLE</b> / DIMENSION <b>SINGLE</b>	1257x900 mm
	1554x900 mm
	1653x900 mm
	1950x900 mm
DIMENSIONI <b>DOUBLE</b> / DIMENSION <b>DOUBLE</b>	1686x850 mm
	1686x900 mm
	2280x850 mm
	2280x900 mm
DIMENSIONI <b>WIDE</b> / DIMENSION <b>WIDE</b>	1620x982 mm
	1620x1032 mm
	1818x982 mm
	1818x1032 mm
DIMENSIONI <b>LARGE</b> / DIMENSION <b>LARGE</b>	1620x1381 mm
	1818x1381 mm
ALTEZZA STANDARD / HEIGHT STANDARD	h. 2134 mm
SPESSORE DEI VETRI / GLASS THICKNESS	8 mm
MANIGLIA / HANDLE	alluminio / aluminum
ALIMENTAZIONE ELETTRICA / POWER SUPPLY	da 2,75 kW a 4,4 kW

## TASTIERA PREMIUM KEYBOARD PREMIUM

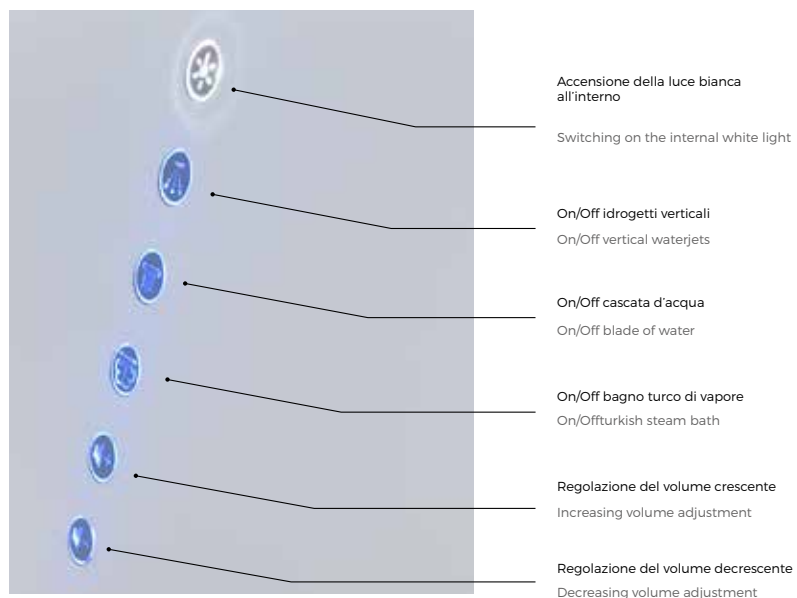

# TECHNICAL FEATURES

## WELLBOX HAMMAM

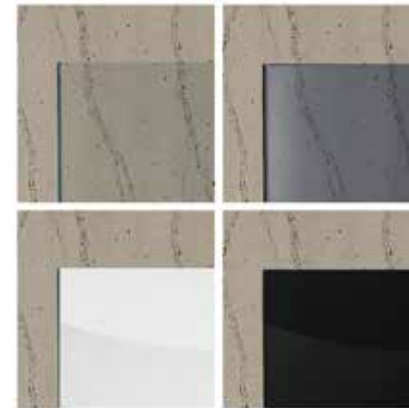

### FINITURE VETRO:

WELLBOX utilizzano per porte e pareti, pannelli in cristallo temperato in lastre da 8 mm, nei colori trasparente e fumè, con trattamento Protective Glass di serie

### GLASS FINISHES:

WELLBOX uses tempered glass panels in 8 mm thick sheets for doors and walls, in transparent, and smoked colors, with Protective Glass treatment as standard.



### FINITURE DOGHE:

Doghe in alluminio verniciato bianco o nero antracite, oppure in legno massello Iroko o Teak.

### SLAT FINISHES:

Slats made of aluminum painted in white or anthracite black, or solid Iroko or Teak wood.



### FINITURE PROFILI:

Tutti i profili (piatto+cabina) sono realizzati in alluminio verniciati di colore bianco o nero antracite.

### PROFILE FINISHES:

All profiles (plate+cabin) are made of aluminum painted in white or anthracite black.



ZEN  
NUDE  
SHOWER  
PIVOT / SLIDING



## La nuova versione di Zen è disponibile in due varianti **NUDE** e **SHOWER**:

- **NUDE**: un ambiente completamente coibentato, privo di colonna e seduta, progettato per l'installazione di generatori di vapore esterni.
- **SHOWER**: dotata di soffione integrato nel tetto, ideale per predisposizioni a muro già esistenti.

Entrambe le varianti si adattano a diversi contesti grazie alle configurazioni disponibili: ad angolo, a parete o in nicchia, con possibilità di scegliere tra porta battente o scorrevole. Le soluzioni possono essere installate direttamente a pavimento, su un piatto doccia Megius o su qualsiasi altro piatto doccia.

## The new Zen version is available in two variants **NUDE** and **SHOWER**:

- **NUDE**: a fully insulated environment, without a column or seat, designed for the installation of external steam generators.
- **SHOWER**: equipped with an integrated overhead showerhead, ideal for pre-existing wall setups.

Both variants adapt to various contexts thanks to the available configurations: corner, wall-mounted, or recessed, with the option to choose between hinged or sliding doors. The solutions can be installed directly on the floor, on a Megius shower tray, or on any other shower tray.

SHOWER VERSION



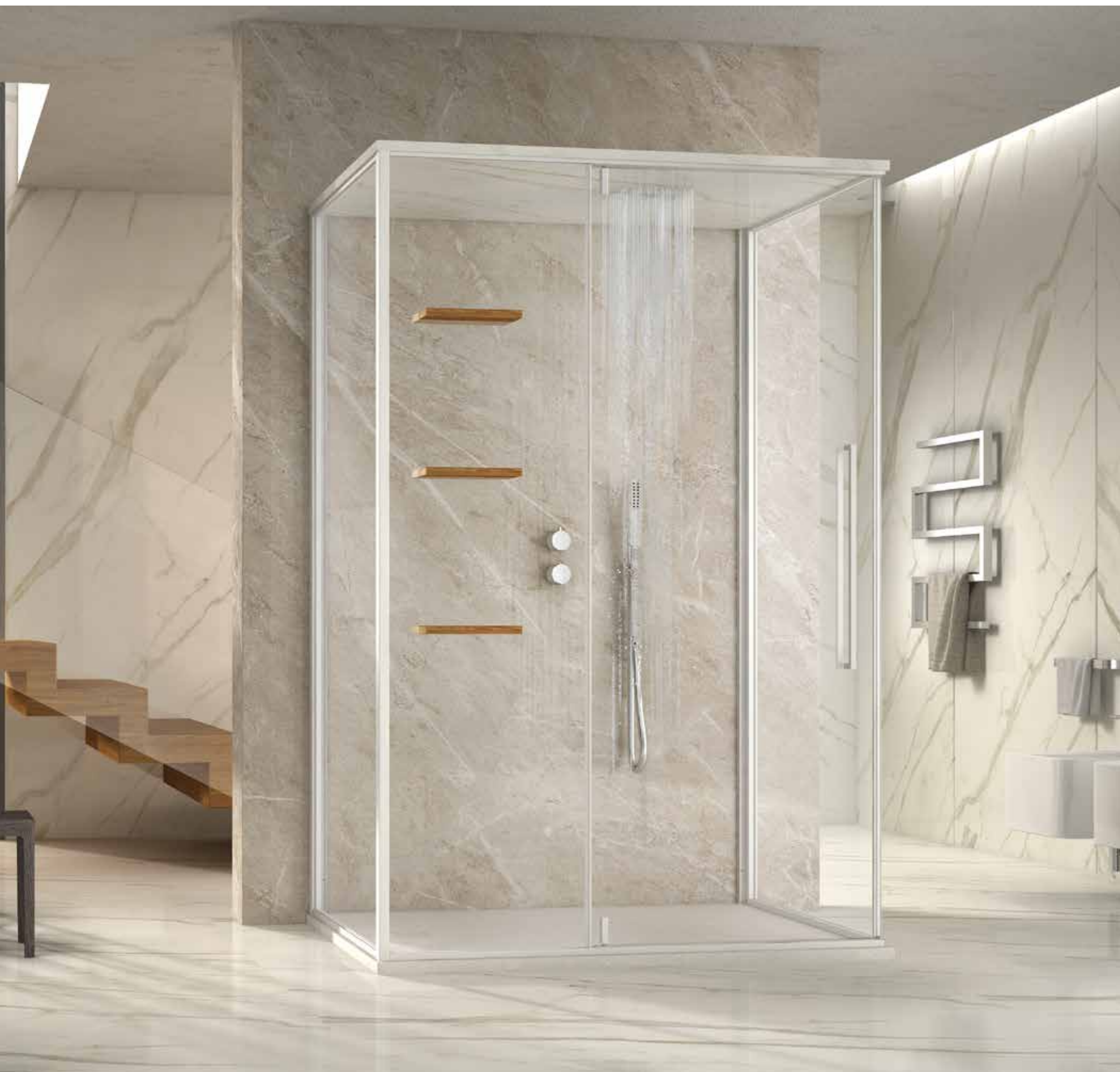





SHOWER VERSION + STEAM-QUADRO





SHOWER VERSION + STEAM-ME SOFT

# SCHEDA TECNICA ZEN

## NUDE / SHOWER

### FINITURA VETRO



Vetro Trasparente "F"

### SEDUTA



Legno Frassino termotrattato

### FINITURE PROFILI

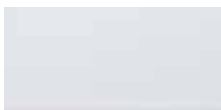

Alluminio Bianco Opaco "E"



Alluminio Argento Spazzolato "F"



Alluminio Nero "Z"



Bianco "E"



Grigio "G"

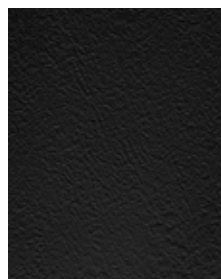

Nero "Z"

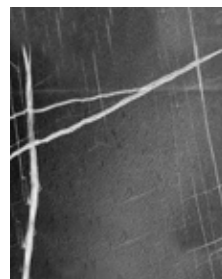

Nero Marquina "2"



White Marble "5"

ALTEZZA STANDARD	h. 2086 mm
SPESSORE DEI VETRI	6 mm
ALTEZZA DELLA MANIGLIA	580 mm
NUMERO DI PERSONE MAX.	2 (art. 1400x1000)
TRATTAMENTO PROTECTIVE	incluso
TEMPI DI SPEDIZIONE	4-5 settimane - *2-3 settimane vers. angolo
APERTURA	pivot - scorrevole

NUDE	SHOWER
CARATTERISTICHE TECNICHE	CARATTERISTICHE TECNICHE
tetto	tetto con soffione 20x20 cm

### OPTIONAL:

Piatto doccia  
Rivestimento pareti parziale o completo

# TECHNICAL FEATURES ZEN

## NUDE / SHOWER

### GLASS FINISH



Transparent tempered glass "F"

### SITTING



Wood Ash heat treated

### PROFILE FINISHES



Matt White Aluminum "E"



Brushed Silver Aluminum "F"

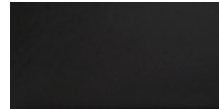

Matt Black Aluminum "Z"



White "E"



Grey "G"

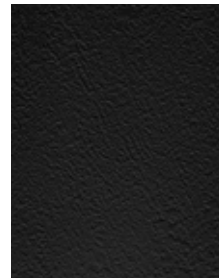

Black "Z"

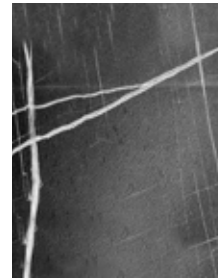

Marquina Black "2"



White Marble "5"

STANDARD HEIGHT	h. 2086 mm
GLASS THICKNESS	6 mm
HANDLE HEIGHT	580 mm
NUMBER OF PEOPLE MAX.	2 (art. 1400x1000)
PROTECTIVE TREATMENT	included
DELIVERY TIME	4-5 weeks - * 2-3 weeks vers. corner
OPENING	pivot - sliding

NUDE	SHOWER
TECHNICAL SPECIFICATIONS	TECHNICAL SPECIFICATIONS
roof	roof with 20x20 cm showerhead

### OPTIONAL:

Shower tray  
Partial or complete wall covering



**ZEN**  
IDRO  
HAMMAM  
PIVOT / SLIDING



Zen, “la doccia impossibile”, evolve nel mondo del wellness con **Zen Idro e Zen Hammam**

Queste soluzioni permettono di integrare un bagno turco anche in ambienti ridotti, come camere o bagni. Disponibili in versioni ad angolo, a parete o in nicchia, offrono un’installazione flessibile, con porta battente centrale e possibilità di posa su qualsiasi piatto doccia o direttamente a pavimento.

Zen, “the impossible shower,” enters the wellness world with **Zen Idro and Zen Hammam**

These solutions bring the steam bath into even compact spaces such as bedrooms or bathrooms. Available in corner, wall-mounted, or recessed versions, they offer flexible installation with a central hinged door and can be placed directly on the floor, on an existing shower tray, or on the Megius Technart base.





## ZEN HAMMAM

Il design minimale e distintivo di Zen si conferma anche nella versione Wellness, arricchita da dettagli funzionali.

Mensole portaoggetti in legno frassino termotrattato sporgono dalle pareti in vetro da 6 mm, disponibili in varie dimensioni. I pannelli di rivestimento opzionali in finitura bianca, nera, grigia o effetto marmo completano l'estetica con un tocco contemporaneo e resistente all'umidità.

The signature minimalist design of Zen is maintained in the Wellness range, now enriched with functional details.

Storage shelves in thermo-treated ash wood extend from the 6 mm glass panels and are available in various sizes. Optional wall cladding panels in white, black, grey, or marble-effect finishes complete the structure with a contemporary, water-resistant look.











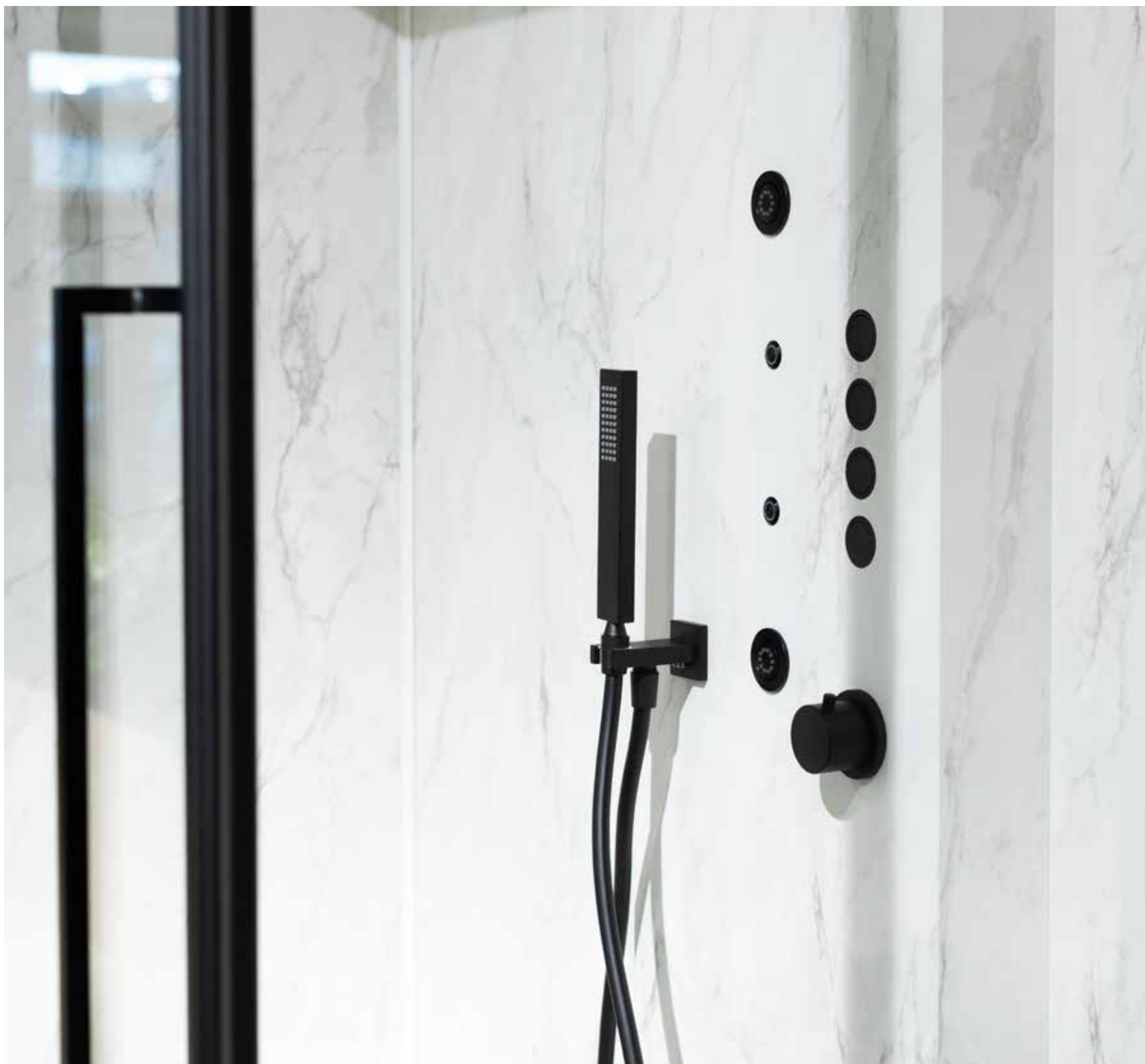





## COMPLETO RELAX

A seconda della configurazione scelta, Zen Idro e Zen Hammam includono una panca fissata alla parete o uno sgabello mobile in frassino termotrattato, per un'esperienza più confortevole da seduti. La porta può essere battente o scorrevole, con maniglia a ponte da 580 mm e sistema di apertura pensato per garantire luminosità e funzionalità.

## COMPLETE RELAXATION

Depending on the chosen setup, Zen Idro and Zen Hammam feature a wall-mounted bench or a mobile stool in thermo-treated ash, offering seated comfort for deeper relaxation. The door—available as hinged or sliding—includes a 580 mm bridge-style handle, enhancing the product's sleek vertical lines.









All'interno di Zen Idro troviamo soffione a tetto, doccia a mano, cascata cervicale e idrogetti dorsali, tutti gestiti da deviatore a pulsanti.

La versione Hammam aggiunge cromoterapia e bagno turco on/off con comandi dedicati. I materiali tecnici in PVC/alluminio garantiscono durabilità, mentre l'opzionale touch display esterno e il sistema audio Bluetooth ampliano l'esperienza wellness a 360 gradi.

Inside Zen Idro, you'll find an overhead shower, hand shower, cervical waterfall, and dorsal jets, all controlled by a modern push-button diverter.

The Hammam version adds chromotherapy and on/off steam bath functions with dedicated controls. Waterproof PVC/aluminium panels ensure long-lasting performance, while optional extras such as a glass touch display and Bluetooth sound system expand the full wellness experience.







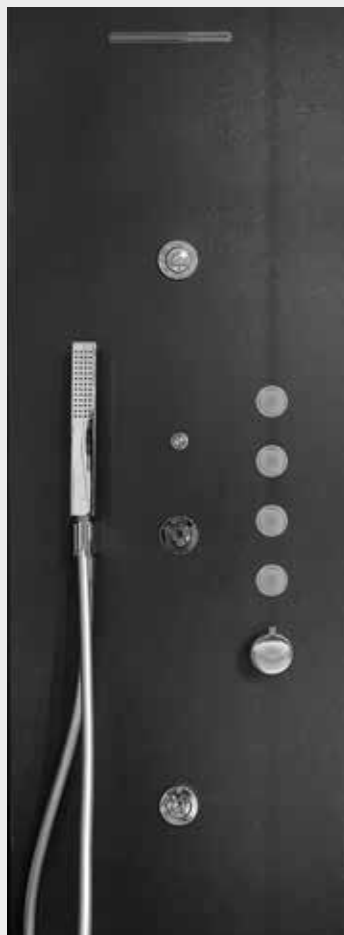

ZEN  
IDRO

IDRO
FUNZIONI
soffione multifunzione 20x20 cm
idrogetti dorsali
cascata d'acqua
doccia a mano

IDRO
FUNCTIONS
multifunction shower head 20x20 cm
dorsal hydrojets
blade of water
hand shower

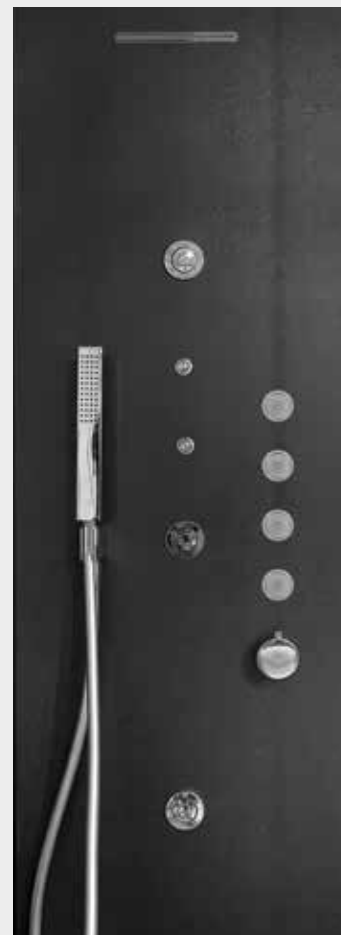
ZEN  
HAMMAM

HAMMAM
FUNZIONI
soffione multifunzione 20x20 cm
1 Strip Led rgb
idrogetti dorsali
pulsante on/off bagno turco
cascata d'acqua
doccia a mano

HAMMAM
FUNCTIONS
multifunction shower head 20x20 cm
1 Strip Led rgb
dorsal hydrojets
Turkish bath on / off button
blade of water
hand shower

# SCHEDA TECNICA ZEN

## IDRO / HAMMAM

### FINITURE VETRO



Vetro Trasparente "F"

### PANCA E MENSOLE



Legno Frassino termotrattato

### FINITURE PROFILI

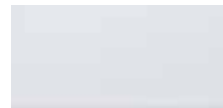

Alluminio Bianco Opaco "E"



Alluminio Argento Spazzolato "F"



Alluminio Nero "Z"



Bianco "E"



Grigio "G"

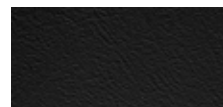

Nero "Z"

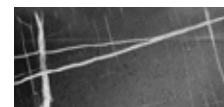

Nero Marquina "2"



White Marble "5"

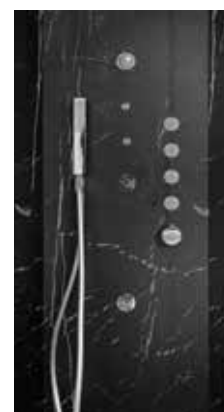

ALTEZZA STANDARD	h. 2086 mm
SPESSORE DEI VETRI	6 mm
ALTEZZA DELLA MANIGLIA	580 mm
ALIMENTAZIONE ELETTRICA	220V Monofase
NUMERO DI PERSONE MAX.	2 (art. 1400x1000)
ILLUMINAZIONE	Strip Led RGB - vers. HAMMAM
TRATTAMENTO PROTECTIVE	incluso
TEMPI DI SPEDIZIONE	4-5 settimane - *2-3 settimane vers. angolo
APERTURA	pivot - scorrevole
POSIZIONE COLONNA	lato lungo - lato corto
MISCELATORE TERMOSTATICO A 4 VIE	incluso

### OPTIONAL:

Piatto doccia  
Rivestimento pareti parziale o completo  
Impianto per musicoterapia (1 casse acustiche)  
Rubinetteria in finitura nero opaco

### IDRO

#### FUNZIONI

soffione multifunzione 20x20 cm

idrogetti dorsali

cascata d'acqua

doccino a mano

### HAMMAM

#### FUNZIONI

soffione multifunzione 20x20 cm

1 Strip Led rgb

idrogetti dorsali

pulsante on/off bagno turco

cascata d'acqua

doccino a mano

# TECHNICAL FEATURES ZEN

## IDRO / HAMMAM

### GLASS FINISH



Transparent tempered glass "F"

### SITTING & SHELVES



Wood Ash heat treated

### PROFILE FINISHES



Matt White Aluminum "E"



Brushed Silver Aluminum "F"



Matt Black Aluminum "Z"



White "E"



Grey "G"



Black "Z"

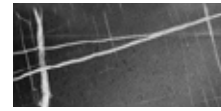

Marquina Black "2"



White Marble "5"

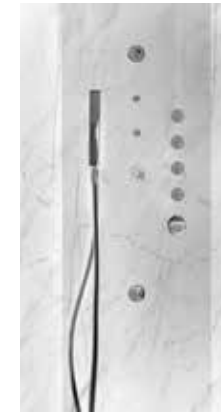
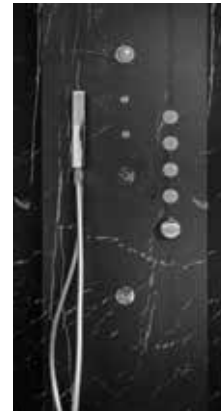

STANDARD HEIGHT	h. 2086 mm
GLASS THICKNESS	6 mm
HANDLE HEIGHT	580 mm
POWER SUPPLY	220V Single-phase
NUMBER OF PEOPLE MAX.	2 (art. 1400x1000)
LIGHTING	Strip Led RGB - vers. HAMMAM
PROTECTIVE TREATMENT	included
DELIVERY TIME	4-5 weeks - * 2-3 weeks vers. corner
OPENING	pivot - sliding
COLUMN POSITIONS	long side - short side
4-WAY THERMOSTATIC MIXER	included

### OPTIONAL:

Shower tray  
 Partial or complete wall covering  
 Music therapy system (1 loudspeaker)  
 Taps in matt black finish

IDRO	HAMMAM
FUNCTIONS	FUNCTIONS
multifunction shower head 20x20 cm	multifunction shower head 20x20 cm
dorsal hydrojets	1 Strip Led rgb
blade of water	dorsal hydrojets
hand shower	Turkish bath on / off button
	blade of water
	hand shower



**STEAM-ME**  
WOOD  
SOFT  
HPL  
STEAM GENERATOR



WOOD



SOFT



HPL

Tutti i benefici del bagno di vapore si uniscono alla più avanzata tecnologia:  
**Steam-Me**

L'innovativa seduta Steam-Me può essere posizionata all'interno della tua cabina doccia, trasformandola in un autentico hammam. È disponibile in due versioni: senza o con cromoterapia, grazie alle fasce luminose LED posizionate sotto la seduta.

All the benefits of a steam bath combined with state-of-the-art technology:  
**Steam-Me**

The innovative Steam-Me seat can be installed inside your shower enclosure, transforming it into a true hammam. Available in two versions, with or without chromotherapy, thanks to LED light strips positioned underneath the seat.























# BAGNO DI VAPORE

Se stai progettando il tuo spazio hammam o cerchi una soluzione compatta, innovativa e facile da usare, Steam-Me è la scelta ideale. Posizionando Steam-Me all'interno della doccia, potrai ricreare un fantastico bagno turco a casa tua, senza ingombri e con un design elegante

# STEAM BATH

If you're designing your hammam space or looking for a compact, stylish, and easy-to-use solution, Steam-Me is the perfect choice. By placing Steam-Me inside the shower, you can recreate a luxurious steam bath experience at home—space-saving, elegant, and highly functional.



In Steam-Me Wood, oltre alla generazione di vapore che fuoriesce dai due erogatori laterali posti nella parte inferiore della seduta, troviamo anche una doccia a mano e un miscelatore per regolare l'acqua.

L'accensione della funzione bagno turco ON/OFF e dei LED per la cromoterapia è semplice, grazie ai pulsanti posti nella parte superiore dell'appoggio lombare. La seduta è dotata di piedini regolabili per un'aderenza ottimale al piatto d'appoggio e, come optional, è disponibile un supporto per l'aromaterapia.

In addition to steam generation, which is released through two side nozzles located at the base of the seat, Steam-Me Wood also includes a handheld shower and a water mixer placed on either side of the lumbar support.

Activating the steam bath ON/OFF function and chromotherapy is simple, thanks to two buttons located on the upper part of the lumbar support. Adjustable feet beneath the seat ensure a secure fit on the shower base. An optional aromatherapy holder is also available.









## STEAM-ME WOOD



Legno Okumè "7"

### HAMMAM

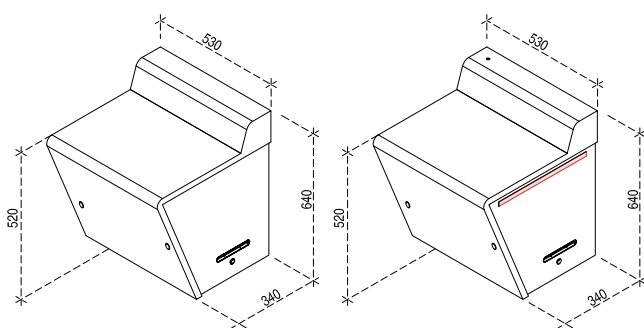

DIMENSIONI	530x520 mm
ALTEZZA	h. 640 mm
ALIMENTAZIONE ELETTRICA	220V Monofase
BAGNO TURCO	on/off
POTENZE DISPONIBILI	2,5 Kw per volumi fino a 3 m <sup>3</sup>
	3,5 Kw per volumi fino a 5 m <sup>3</sup>
TEMPI DI SPEDIZIONE	4-5 settimane

### IDRO + HAMMAM

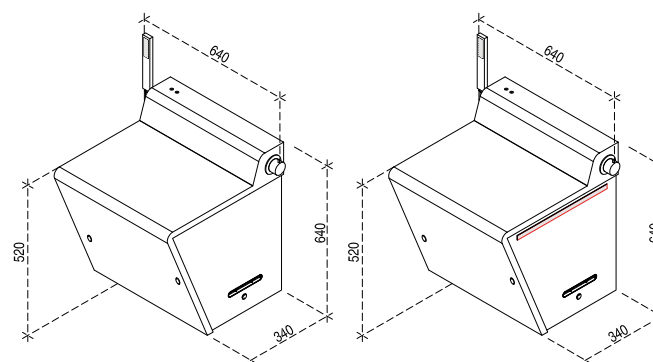

DIMENSIONI	530x520 mm
ALTEZZA	h. 640 mm
ALIMENTAZIONE ELETTRICA	220V Monofase
ILLUMINAZIONE	n°2 Strip Led inserito nella seduta (optional)
DOCCINO	a mano incluso
BAGNO TURCO	on/off
POTENZE DISPONIBILI	2,5 Kw per volumi fino a 3 m <sup>3</sup>
	3,5 Kw per volumi fino a 5 m <sup>3</sup>
TEMPI DI SPEDIZIONE	4-5 settimane

## STEAM-ME SOFT

### MATERIALE SEDUTA IN PVC MORBIDO



Soft Antracite "B"



Soft Tortora "T"

### MATERIALE RIVESTIMENTO LATERALE



Legno Frassino termotrattato

DIMENSIONI	530x520 mm
ALTEZZA	h. 520 mm
ALIMENTAZIONE ELETTRICA	220V Monofase
ILLUMINAZIONE	n°2 Strip Led inserito nella seduta (optional)
DOCCINO	a mano incluso
BAGNO TURCO	on/off
POTENZE DISPONIBILI	2.5 Kw per volumi fino a 4,99 m <sup>3</sup> 3.5 Kw per volumi fino a 6,99 m <sup>3</sup>
TEMPI DI SPEDIZIONE	4-5 settimane

### IDRO + HAMMAM

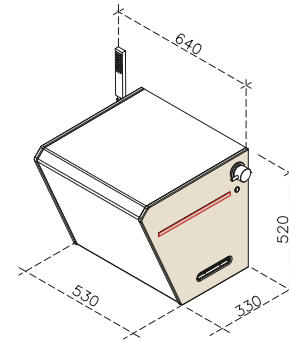
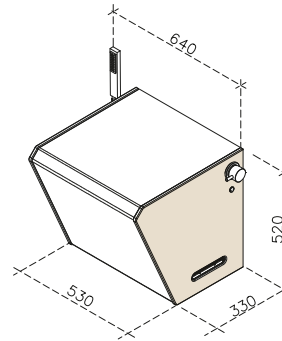

## STEAM-ME HPL

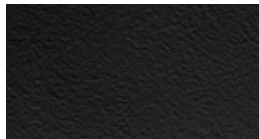

Nero "Z"

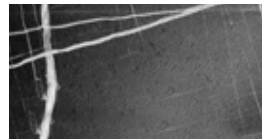

Nero Marquina "2"



White Marble "5"



Bianco "E"



Grigio "G"

DIMENSIONI	530x520 mm
ALTEZZA	h. 520 mm
ALIMENTAZIONE ELETTRICA	220V Monofase
ILLUMINAZIONE	n°2 Strip Led inserito nella seduta (optional)
DOCCINO	a mano incluso
BAGNO TURCO	on/off
POTENZE DISPONIBILI	2.5 Kw per volumi fino a 4,99 m <sup>3</sup> 3.5 Kw per volumi fino a 6,99 m <sup>3</sup>
TEMPI DI SPEDIZIONE	4-5 settimane

### IDRO + HAMMAM

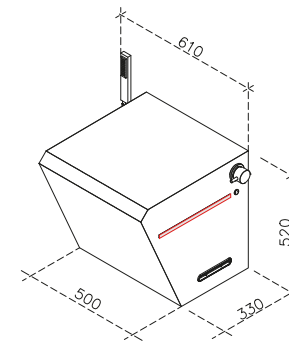
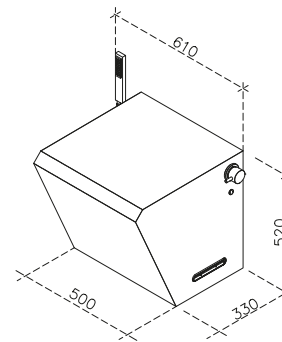

## STEAM-ME WOOD



Wood Okumè "7"

### HAMMAM

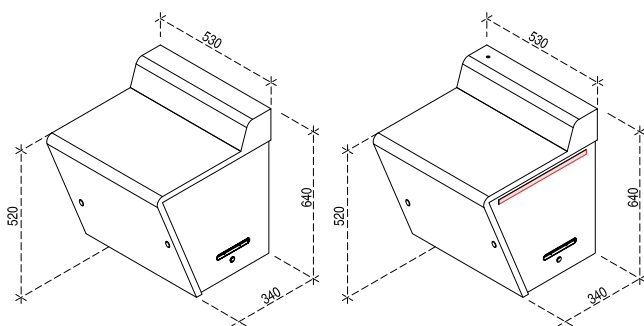

DIMENSION	530x520 mm
HEIGHT	h. 640 mm
POWER SUPPLY	220V Single phase
TURKISH BATH	on/off
AVAILABLE POWER	2.5 Kw for volumes up to 3 m <sup>3</sup>
	3.5 Kw for volumes up to 5 m <sup>3</sup>
DELIVERY TIME	4-5 weeks

### IDRO + HAMMAM

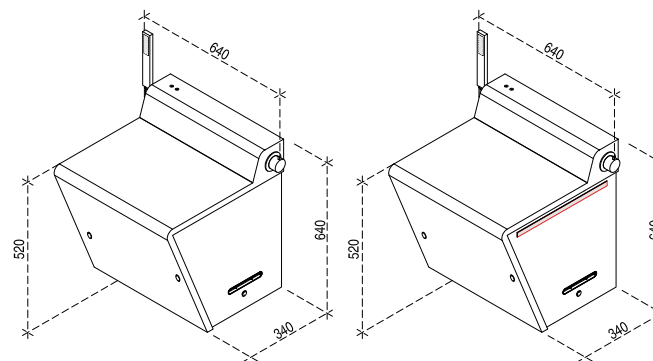

DIMENSION	530x520 mm
HEIGHT	h. 640 mm
POWER SUPPLY	220V Single phase
LIGHTING	n°2 Strip Led inserted in the session (optional)
HAND SHOWER	included
TURKISH BATH	on/off
AVAILABLE POWER	2.5 Kw for volumes up to 3 m <sup>3</sup>
	3.5 Kw for volumes up to 5 m <sup>3</sup>
DELIVERY TIME	4-5 weeks

## STEAM-ME SOFT



Soft Anthracite "B"



Soft Dove Grey "T"



Wood Ash heat treated

DIMENSION	530x520 mm
HEIGHT	h. 520 mm
POWER SUPPLY	220V Single phase
LIGHTING	n°2 Strip Led inserted in the session (optional)
HAND SHOWER	included
TURKISH BATH	on/off
AVAILABLE POWER	2.5 Kw for volumes up to 4,99 m <sup>3</sup>
	3.5 Kw for volumes up to 6,99 m <sup>3</sup>
DELIVERY TIME	4-5 weeks

### IDRO + HAMMAM

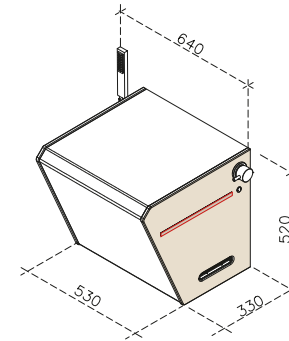
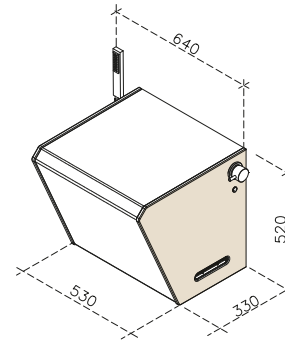

## STEAM-ME HPL

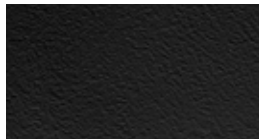

Black "Z"

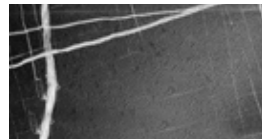

Marquina Black "2"



White Marble "5"



White "E"



Grey "G"

DIMENSION	530x520 mm
HEIGHT	h. 520 mm
POWER SUPPLY	220V Single phase
LIGHTING	n°2 Strip Led inserted in the session (optional)
HAND SHOWER	included
TURKISH BATH	on/off
AVAILABLE POWER	2.5 Kw for volumes up to 4,99 m <sup>3</sup>
	3.5 Kw for volumes up to 6,99 m <sup>3</sup>
DELIVERY TIME	4-5 weeks

### IDRO + HAMMAM

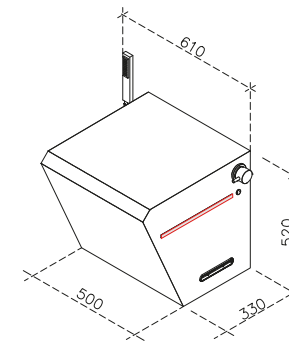
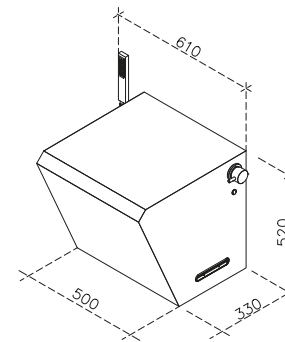



**STEAM  
QUADRO**  
STEAM GENERATOR



## L'hammam perfetto per ogni spazio

Tradizionalmente, l'hammam richiama l'idea di strutture ingombranti e difficili da inserire in contesti domestici o contract. Con Steam-Quadro questo concetto viene superato. Progettato per ottimizzare gli spazi senza rinunciare alla qualità del benessere, rappresenta una delle soluzioni salvaspazio più innovative di Megius.

In soli 610 x 755 mm, Steam-Quadro racchiude tutta la tecnologia di un hammam completo, integrando funzioni acqua, cromoterapia e generazione di vapore. Realizzato con il rivoluzionario pannello Zen Layer, già impiegato in altre collezioni Megius, garantisce un perfetto equilibrio tra performance e versatilità.

## The perfect hammam for any space

Traditionally, a hammam brings to mind large, bulky installations, often difficult to incorporate into domestic or contract environments. Steam-Quadro changes this perception. Designed to optimize space without compromising on wellness, it stands as one of Megius' most innovative space-saving solutions.

In just 610 x 755 mm, Steam-Quadro integrates all the technology of a complete hammam, including water functions, chromotherapy, and steam generation. Made with the revolutionary Zen Layer panel—already used in other Megius collections—it achieves the perfect balance between performance and versatility.

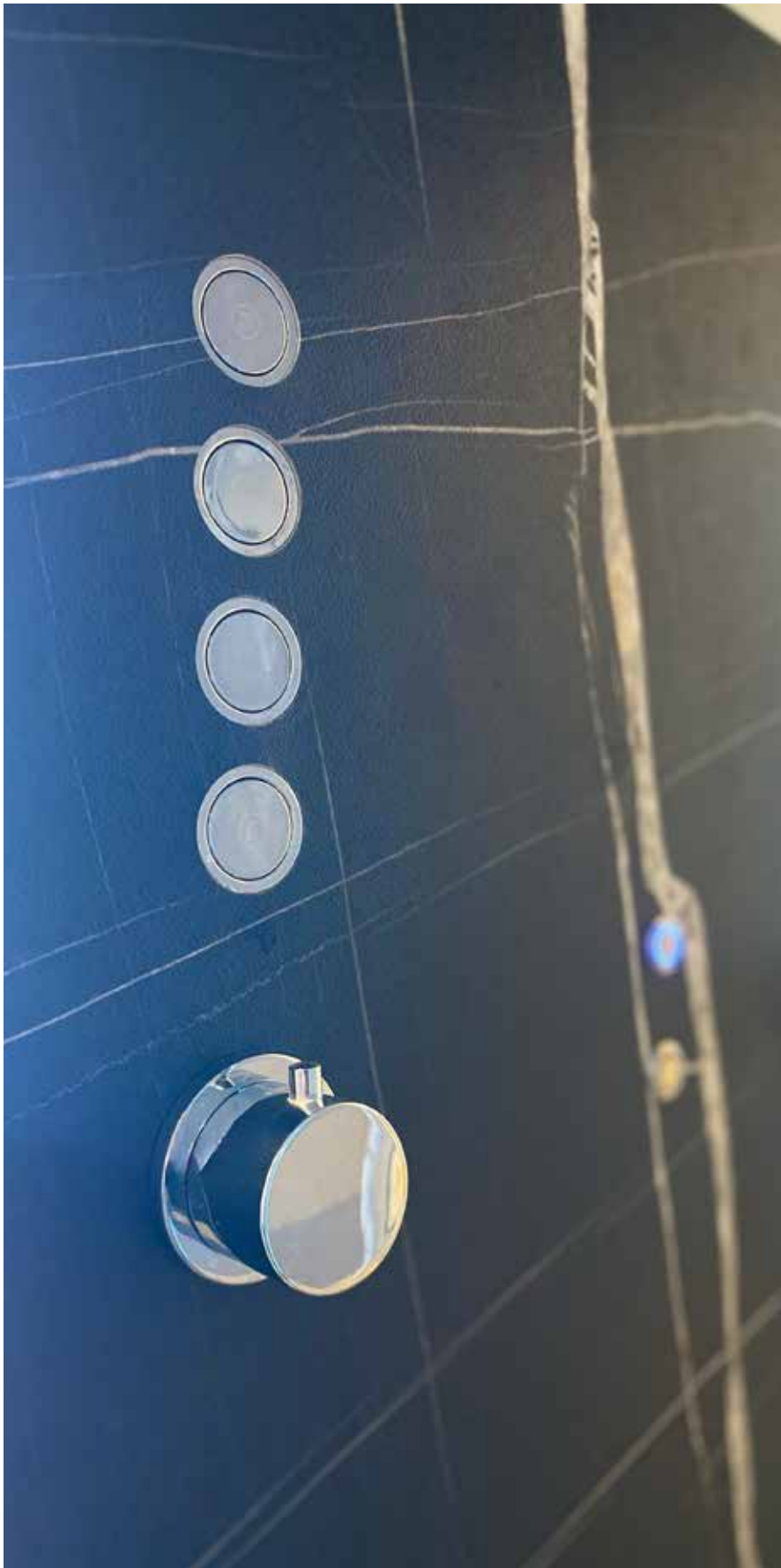

Perfetto per ambienti su misura, Steam-Quadro può essere integrato facilmente sia in strutture coibentate che in ambienti in muratura già esistenti, offrendo un'esperienza di vapore intensa e rigenerante. Il design elegante e moderno è arricchito da pulsanti ergonomici e intuitivi, che ne semplificano l'utilizzo e aggiungono un tocco di stile. Steam-Quadro è molto più di un semplice prodotto wellness: è un elemento distintivo e funzionale per ogni spazio.

Ideal for custom environments, Steam-Quadro can be seamlessly integrated into both insulated structures and existing masonry setups, offering an intense and revitalizing steam experience. Its sleek, contemporary design is enhanced by intuitive, ergonomic buttons that simplify its use while adding a stylish touch. Steam-Quadro is not only a wellness feature—it's a refined and functional design element for any space.



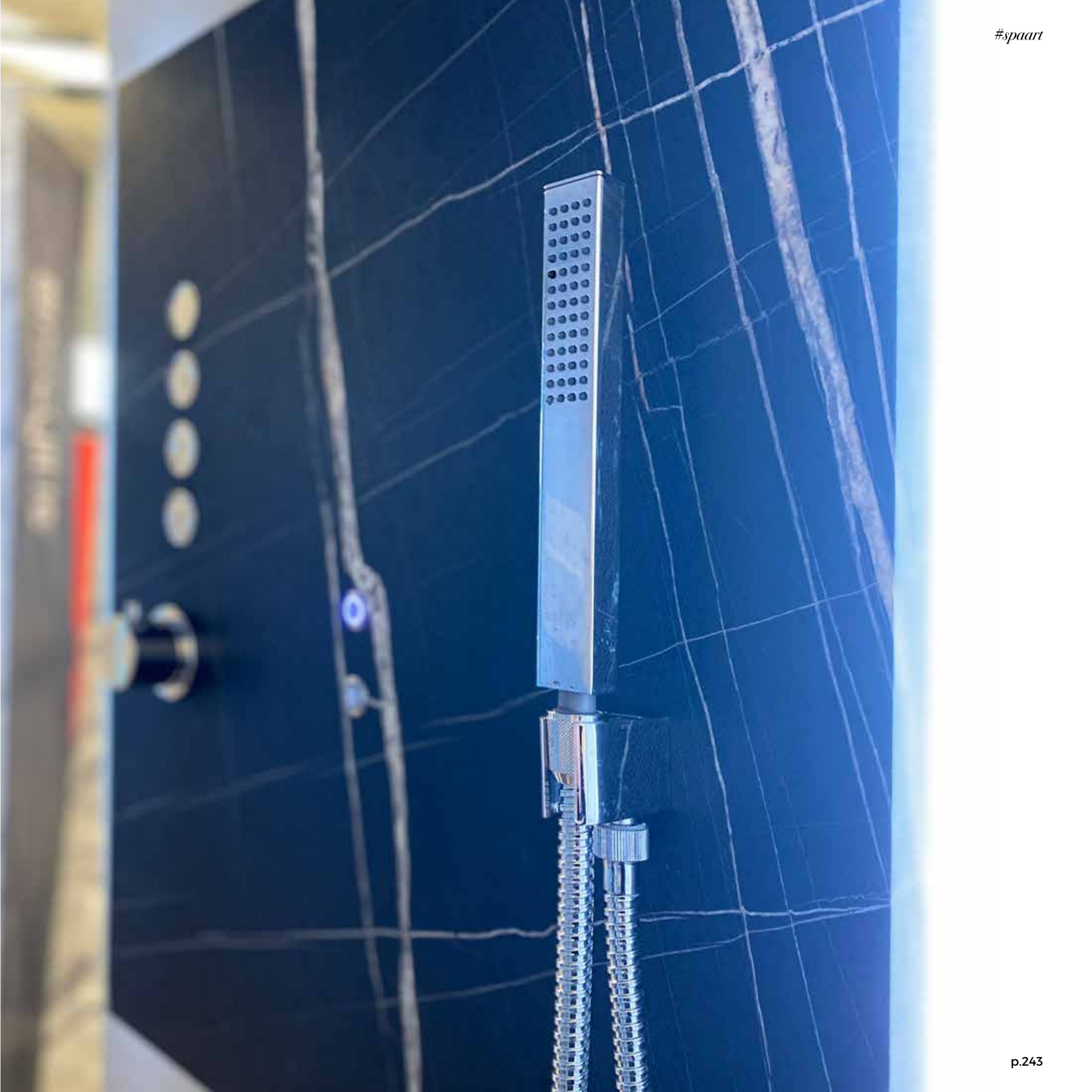

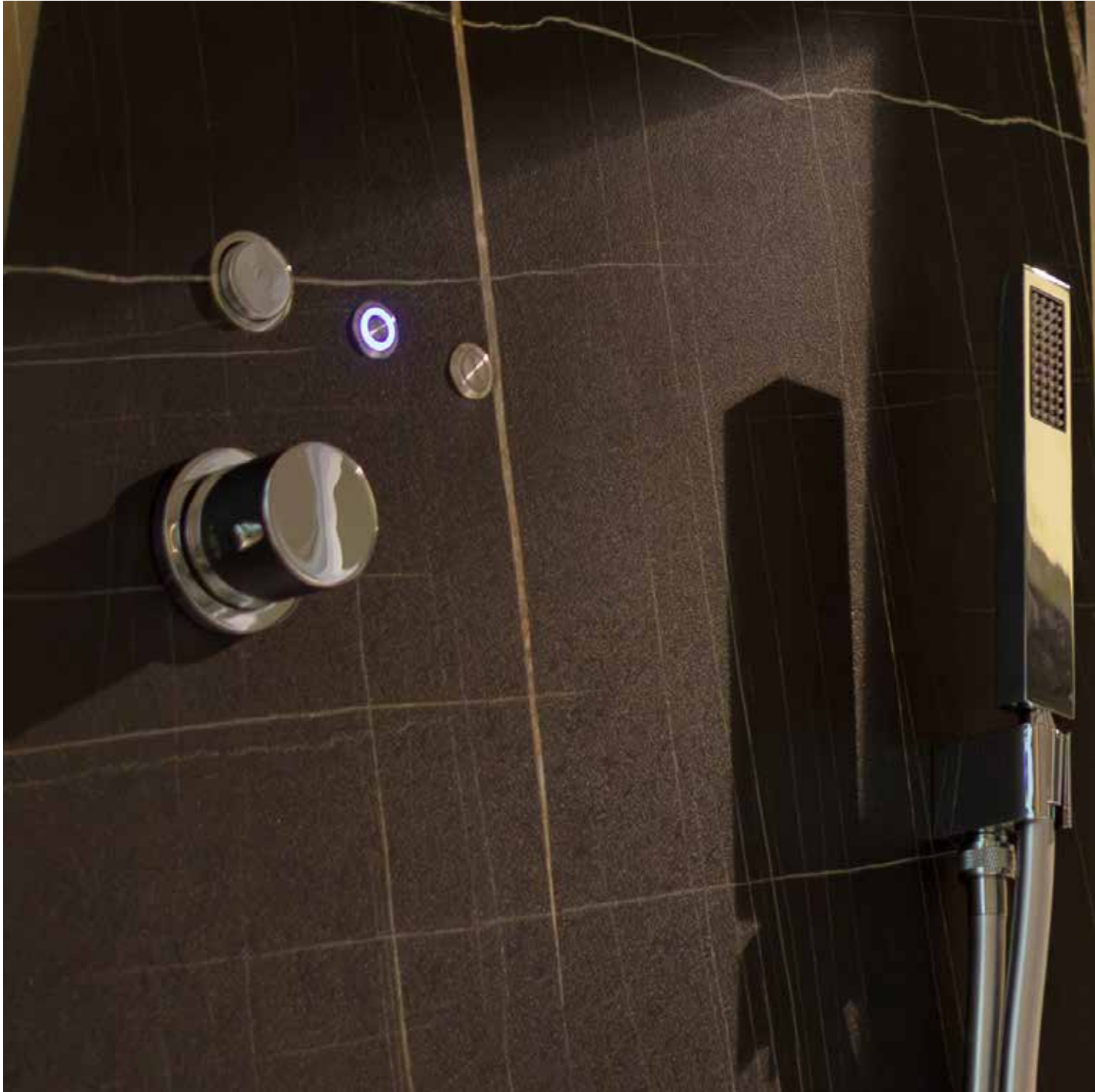





# STEAM-QUADRO

## GENERAZIONE PER L'USO DOMESTICO

Perfetto per abitazioni private, questo generatore di vapore è progettato con la massima compatibilità e sicurezza, ed è offerto in diverse versioni e colori per rispondere alle esigenze di ogni cliente. È progettato per un utilizzo occasionale.



Black "Z"

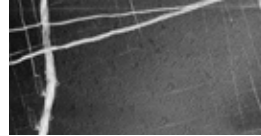

Marq Black "Z"



White Marble "5"



White "E"



Grigio "G3"

Essendo un componente  
elettronico, il generatore  
di vapore è un componente  
elettronico che richiede  
mixelato con il cordone  
cromato per un utilizzo  
occasionale.

**OPTIONAL**  
sotto il (vedi pagina n° 92)

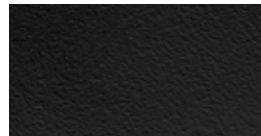
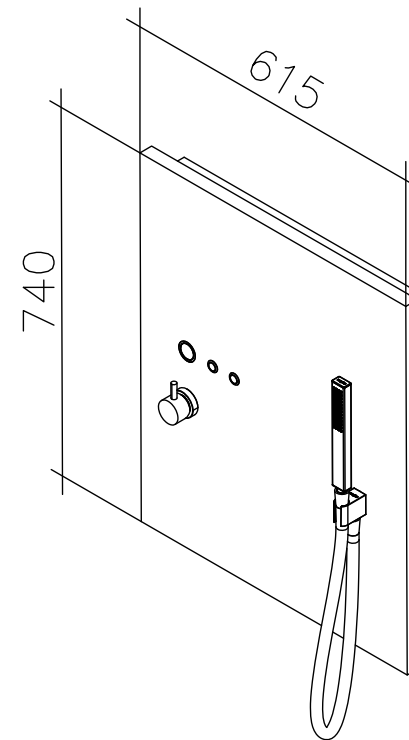

White Marble "5"





# STEAM MISTERY

STEAM GENERATOR



La soluzione ottimale per realizzare nella propria casa un bagno turco ad alte prestazioni anche in spazi ridotti.

Grazie alle sue dimensioni compatte, Steam-Mistery non necessita di un locale tecnico dedicato: può essere infatti, alloggiato sopra il controsoffitto dell'hammam, oppure può essere collocato in un locale tecnico adiacente.

Steam-Mistery è una soluzione efficiente anche nel caso si desideri ammodernare il vano doccia esistente in bagno turco.

The optimal solution for creating a high-performance Turkish bath in your home, even in small spaces.

Thanks to its compact size, Steam-Mistery does not require a dedicated technical room: it can be housed above the hammam ceiling or placed in an adjacent technical room.

Steam-Mistery is also an efficient solution if you wish to modernize your existing shower room into a Turkish bath.



# ENTRA IN UNA NUVOLA DI VAPORE

Steam-Mistery è un generatore di vapore che abbina un'elevata tecnologia alla semplicità di utilizzo.

Grazie alle dimensioni compatte, presenta un pannello di controllo touch con icone retroilluminate e un indicatore del livello di temperatura. È disponibile in due modelli di differenti potenze, trasformando così la tua doccia in un piacevole bagno turco di alta tecnologia e semplice da utilizzare. Mistery è il prodotto ideale per completare il bagno di casa e renderlo un'area dedicata al benessere.

# ENTER A CLOUD OF STEAM

Steam-Mistery is a steam generator that combines high technology with ease of use.

Thanks to its compact size, it features a touch control panel with backlit icons and a temperature level indicator. It is available in two models with different powers, thus transforming your shower into a pleasant high-tech and easy-to-use Turkish bath. Mistery is the ideal product to complete your home bathroom and make it an area dedicated to well-being.



### **Integrated Spa control**

Il nuovo Touch display presenta un'importante novità: è compatibile con la maggior parte dei prodotti wellness Megius, permettendo di combinare e gestire le loro diverse funzioni tra sauna e hammam in modo sinergico tra prodotti con diverse caratteristiche. Disponibile in due colori: bianco e nero.

### **Integrated Spa control**

The new Touch Display introduces an important innovation: it is compatible with most Megius wellness products, allowing for the combination and management of their diverse functions in a synergistic way among products with different features. Available in two colors: white and black.

# GENERATORI DI VAPORE

Questi generatori rappresentano la soluzione ideale per creare un bagno turco ad alte prestazioni, perfetto sia per spazi ridotti che per ambienti più ampi. Adatti sia all'uso domestico che professionale, garantiscono prestazioni eccellenti anche in grandi spazi. Possono essere installati internamente o esternamente all'ambiente da riempire di vapore, offrendo massima flessibilità e funzionalità.

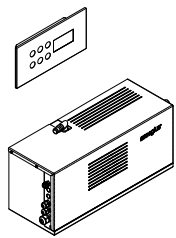

## Steam-Mistery

3-5 kW / 4-6 m<sup>3</sup> / 4-7 kg/h

GENERATORE DI VAPORE PER USO DOMESTICO

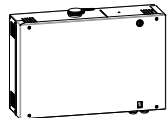

## Steam-Mistery Comfort

3-5 kW / 4-6 m<sup>3</sup> / 7-9,75 kg/h

GENERATORE DI VAPORE PER USO PROFESSIONALE CONTINUATIVO

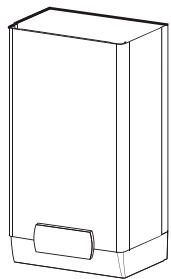

## Steam-Mistery Pro

6,75-11,25 kW / 9-15 m<sup>3</sup> / 9-15 kg/h

su richiesta fino a 40 m<sup>3</sup>

GENERATORE DI VAPORE PER USO PROFESSIONALE CONTINUATIVO

# STEAM GENERATORS

These generators are the ideal solution for creating a high-performance steam bath, perfect for both small spaces and larger environments. Suitable for both domestic and professional use, they ensure excellent performance even in large areas. They can be installed either inside or outside the space to be filled with steam, providing maximum flexibility and functionality.

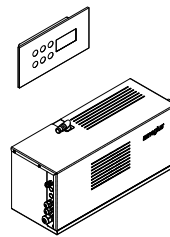

## Steam-Mistery

3-5 kW / 4-6 m<sup>3</sup> / 4-7 kg/h

STEAM GENERATOR FOR DOMESTIC USE



## Steam-Mistery Comfort

3-5 kW / 4-6 m<sup>3</sup> / 7-9,75 kg/h

PROFESSIONAL STEAM GENERATOR FOR CONTINUOUS USE

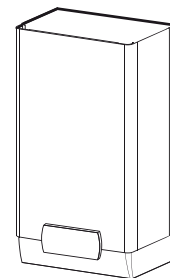

## Steam-Mistery Pro

6,75-11,25 kW / 9-15 m<sup>3</sup> / 9-15 kg/h

On request up to 40 m<sup>3</sup>

PROFESSIONAL STEAM GENERATOR FOR CONTINUOUS USE



# WELLZONE

HAMMAM CUSTOM



## Home spa completamente personalizzata

Lasciati avvolgere dal rito del relax all'interno di una doccia emozionale e hammam: rigenera il tuo corpo in una vera e propria spa. Appliciamo la nostra conoscenza e competenza nell'ambito del benessere per garantire il miglior risultato in un ambiente progettato appositamente per te, secondo le tue esigenze e rispettando il tuo gusto.

## Fully customized home spa

Let yourself be enveloped in the ritual of relaxation in an emotional shower and hammam: regenerate your body in a real spa. We apply our knowledge and expertise in the field of wellness to guarantee the best results. We apply our knowledge and expertise in the field of wellness to ensure the best results in an environment designed specifically for you, according to your needs and taste.

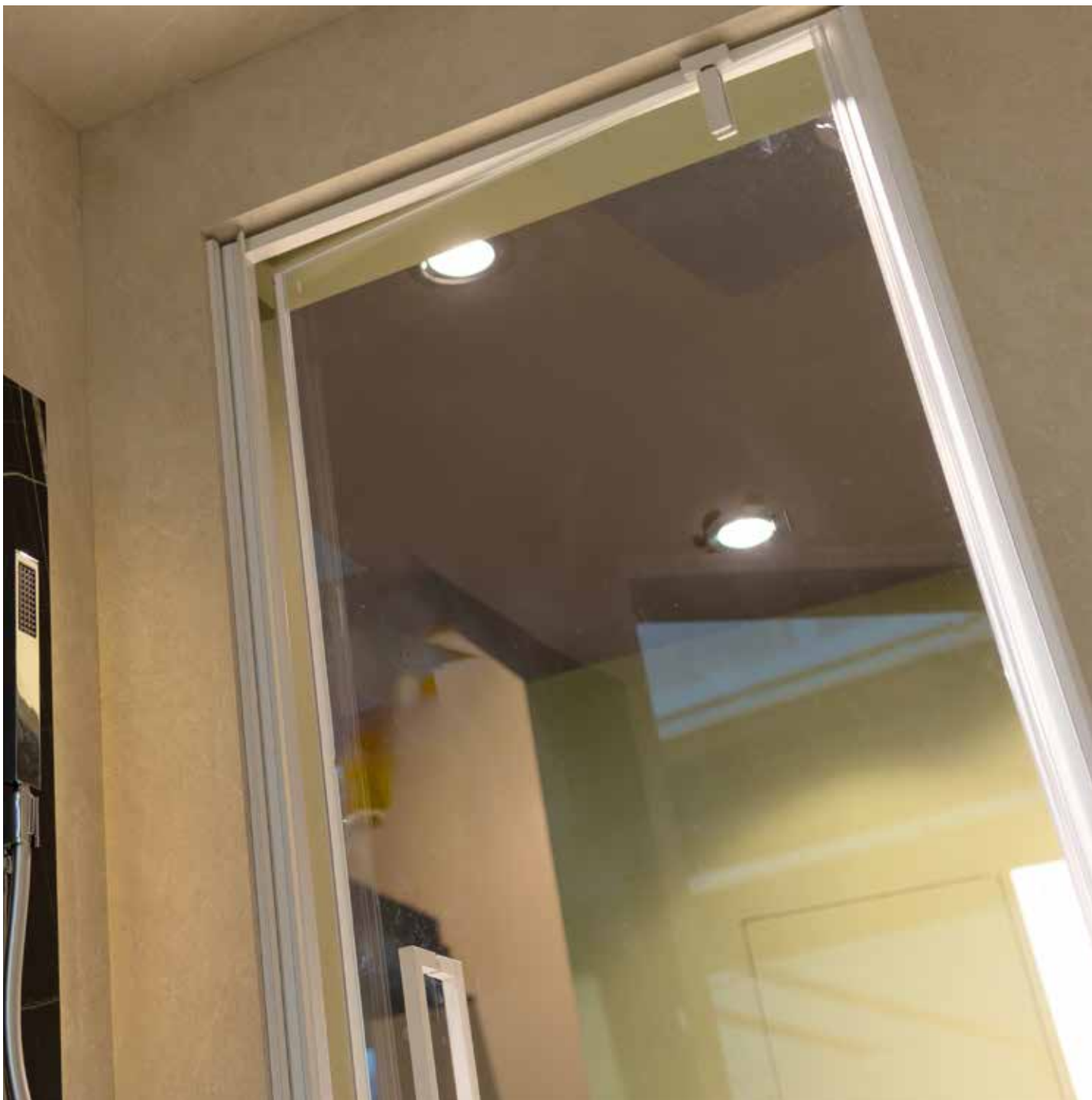







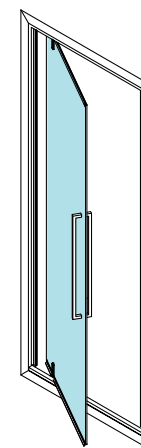

PV

Porta battente

PV

Pivot door

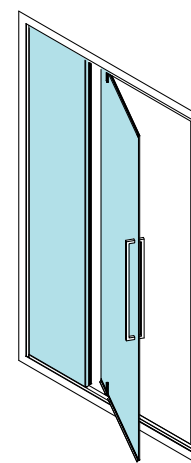

PVF

Porta battente con fisso

PVF

Pivot door with fixed side

# REALIZZA IL TUO HAMMAM

**LA HOME SPA E LE SUITE SPA GRAZIE A MEGIUS  
DIVENTANO UNA REALTÀ POSSIBILE:**

Il wellness moderno propone soluzioni innovative di Hammam rivolte a una dimensione domestica o a spazi ridotti all'interno di Suite Spa che non richiedono apparecchiature elettriche particolari, sono infatti pratiche e user friendly. La nostra competenza e lo studio degli spazi nell'ambito del wellness permettono di inserire in modo coerente all'interno degli ambienti materiali di alta qualità, la possibilità di personalizzazione con l'inserimento della cromoterapia e/o aromaterapia.

# CREATE YOUR HAMMAM

**THE HOME SPA AND SUITE SPA THANKS TO MEGIUS  
BECOME A POSSIBLE REALITY:**

Modern wellness proposes innovative Hammam solutions aimed at a domestic dimension or at small spaces in Spa Suites that do not require special electrical equipment, they are practical and user friendly. Our competence and the study of spaces in the wellness sector allow us to insert high-quality materials in a coherent way inside the environments, the possibility of personalization with the insertion of chromotherapy and/or aromatherapy.

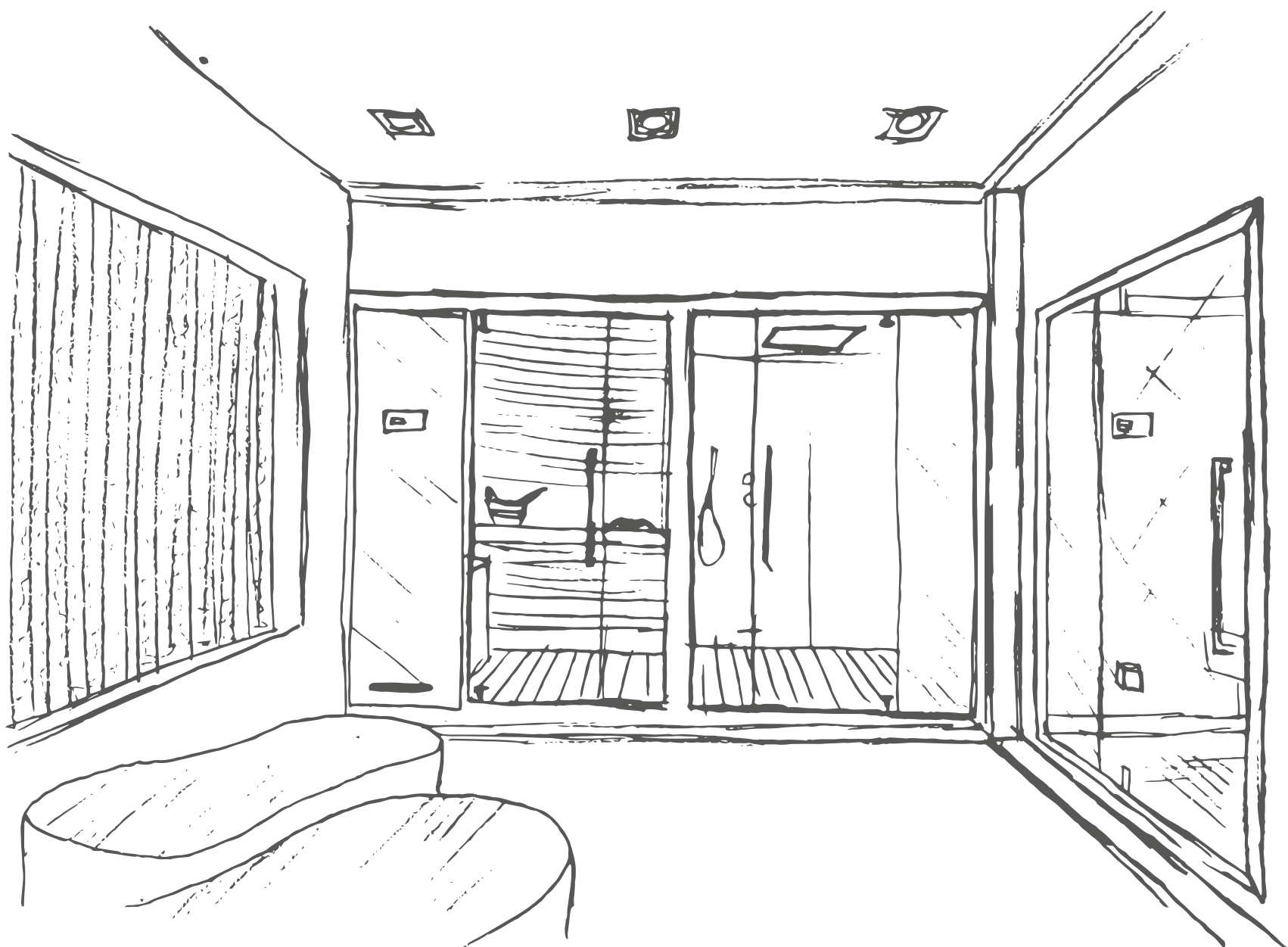

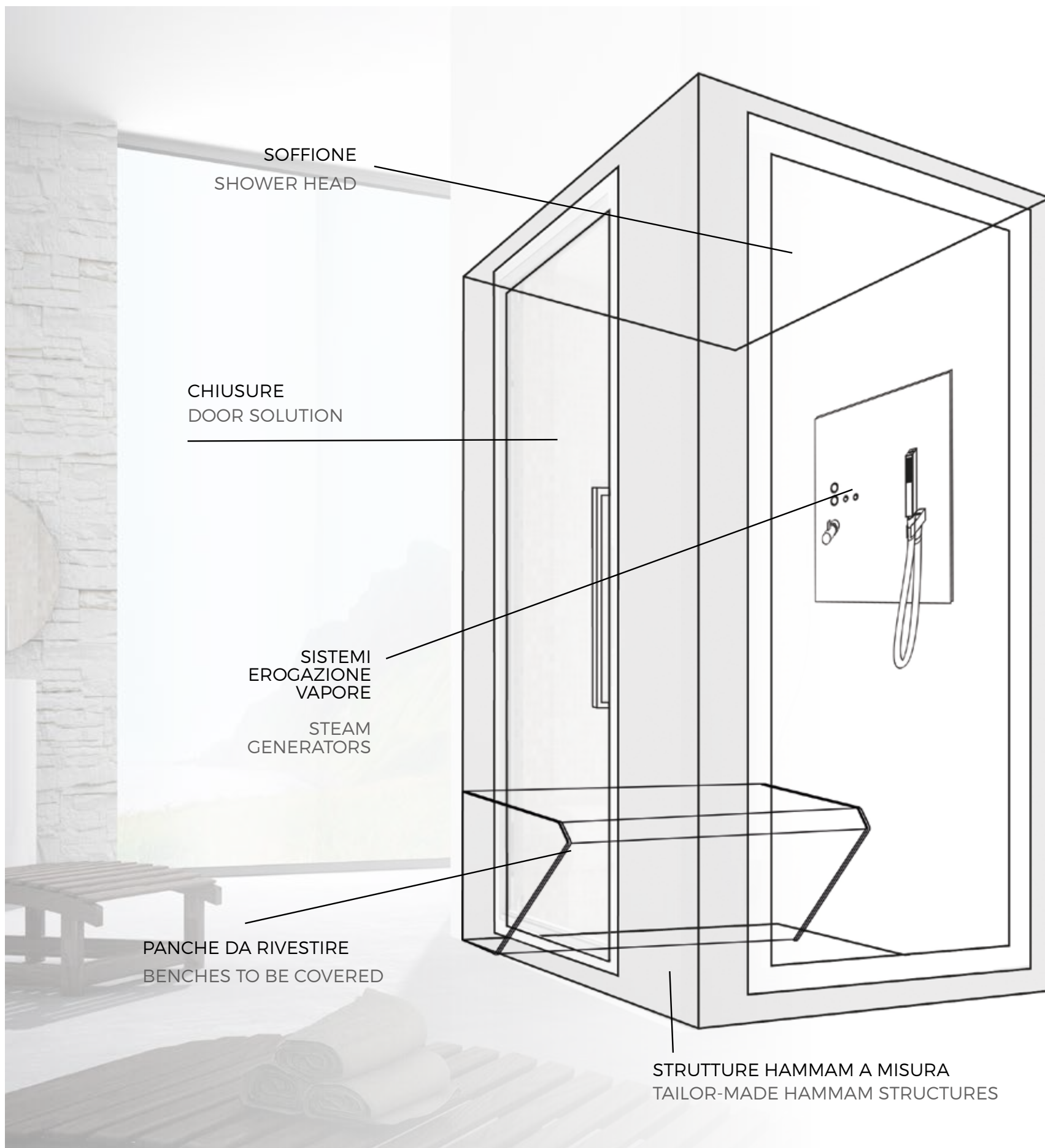



RASO DOCCIA  
SHOWER

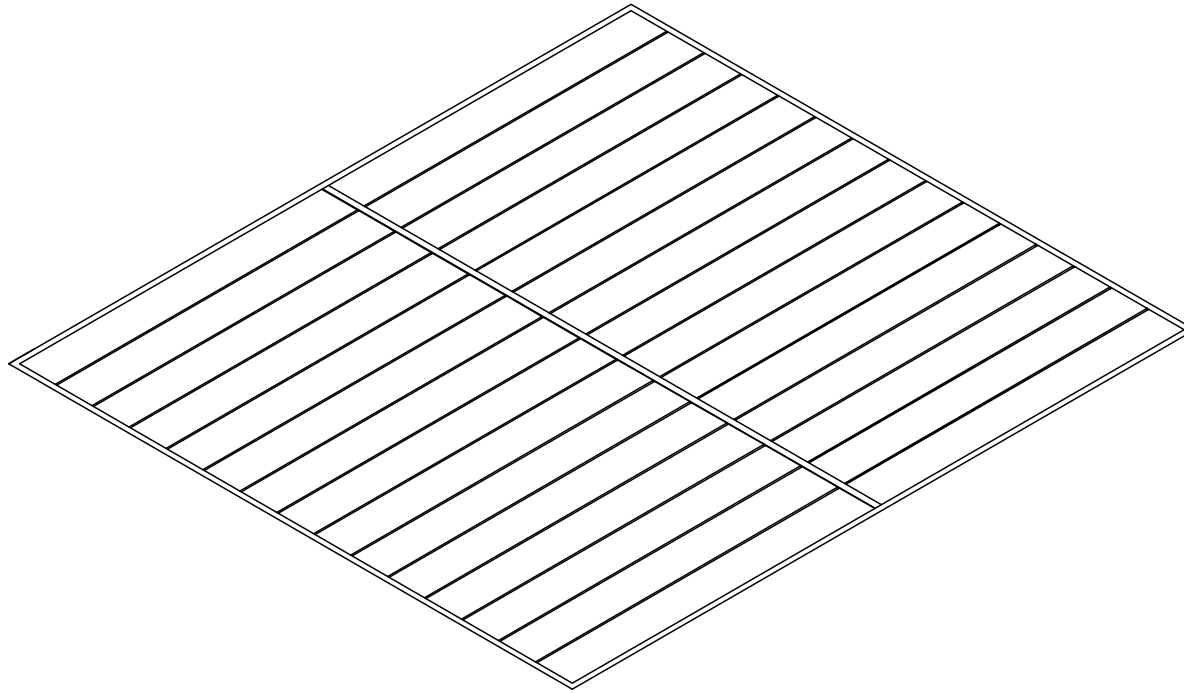

**In Rasodoccia la cabina di cristallo e il piatto doccia sono integrati in un unico sistema, all'insegna dell'essenzialità.**

Il piatto è composto da un telaio in alluminio e una vasca di raccolta acqua coperta da doghe in legno o in alluminio, che costituiscono il piano calpestabile della cabina doccia, posato ad incasso nel pavimento.

Il profilo perimetrale permette di montare su ogni lato diverse tipologie di lastre in vetro temperato da 8mm oppure rivestimenti da parete, come piastrelle e pannelli in mosaico o marmo.

**LA CARATTERISTICA PIÙ IMPORTANTE È LA VERSATILITÀ A 360° DEL SISTEMA!**

Per realizzare una cabina doccia su misura, sono disponibili 30 lunghezze (da 828 mm a 4032 mm) combinabili con 6 profondità.

**In Rasodoccia the glass enclosure and shower tray are integrated into a single system, in the name of simplicity.**

The tray consists of an aluminium frame and a water collection basin covered by wooden or aluminium slats, which form the walkable surface of the shower enclosure, laid flush with the floor.

The perimeter profile allows different types of 8mm tempered glass panels or wall coverings, such as mosaic or marble tiles and panels, to be fitted on each side.

**THE MOST IMPORTANT FEATURE IS THE 360° VERSATILITY OF THE SYSTEM!**

To create a made-to-measure shower enclosure, 30 lengths are available (from 828 mm to 4032 mm) that can be combined with 6 depths.





Nella serie Rasodoccia, il piatto e la cabina doccia sono integrati in un sistema unico, all'insegna dell'essenzialità. Il piatto è composto da un telaio in alluminio e una vasca per la raccolta dell'acqua, coperta da doghe in legno o alluminio.

Il profilo perimetrale permette di montare su ogni lato del piatto diverse tipologie di lastre in vetro temperato da 8mm oppure rivestimenti da parete come le tradizionali piastrelle in mosaico o marmo.

In the Rasodoccia series, the shower tray and shower enclosure are integrated in a single, essential system.

The shower tray consists of an aluminium frame and a water collection basin covered by wooden or aluminium slats.

The perimeter profile makes it possible to install different types of 8mm tempered glass panels or wall coverings such as traditional mosaic or marble tiles on each side of the tray.



# EFFETTO SCENICO

RASODOCCIA È UN SISTEMA VERSATILE A 360°

Negli anni avete imparato ad amare e apprezzare la nostra serie Rasofilo di Megius Spa, un prodotto di alto design dove il piatto doccia e la cabina doccia sono integrati in un unico sistema, con la presenza di doghe in legno o alluminio, che si uniscono alla lastra di vetro, donando pulizia ed eleganza.

# SCENIC EFFECT

RASODOCCIA IS AN ALL-ROUND VERSATILE SYSTEM

Over the years you have learned to love and appreciate our Rasofilo series by Megius Spa, a high design product where the shower tray and shower enclosure are integrated in a single system, with the presence of wooden or aluminium slats, which join the glass panel, giving cleanliness and elegance.





Di fronte alla linearità e alla pulizia delle forme della zona bagno, Megius propone l'installazione di Rasodoccia, un prodotto all'insegna dell'essenzialità in grado di inserirsi perfettamente in questo contesto.

Faced with the linearity and cleanliness of the shapes of the bathroom area, Megius proposes the installation of Rasodoccia, a product in the name of essentiality that can fit perfectly into this context.





La colonna soffione del sistema RASODOCCIA + FILODOCCIA è interamente realizzata in ottone cromato ed ha un diametro di 220 mm con il particolare braccio è regolabile a  $+30^\circ$  /  $-30^\circ$ . Il soffione è dotato di particolari ugelli in gomma siliconica Easy Clean, che ne facilitano la pulizia, assicurano un'abbondante flusso e un'uniforme distribuzione dell'acqua.

The shower head column of the RASODOCCIA + FILODOCCIA system is entirely made of chrome-plated brass and has a diameter of 220 mm. The special arm is adjustable at  $+30^\circ$  /  $-30^\circ$ .

The showerhead is equipped with special Easy Clean silicone rubber nozzles, which make it easy to clean and ensure an abundant flow and even distribution of water.

Il sistema di miscelazione dell'acqua è a regolazione termostatica. La doccetta è collegata al corpo miscelatore da un tubo flessibile; la funzione doccetta / soffione è comandata da un deviatore.

La colonna soffione viene installata direttamente all'interno del piatto doccia, attraverso un sistema di innesto specifico che ne permette l'utilizzo nel sistema RASODOCCIA + FILODOCCIA.

The water mixing system is thermostatically controlled. The hand shower is connected to the mixer body by a flexible hose; the hand/head shower function is controlled by a diverter. The shower head column is installed directly inside the shower tray, through a specific coupling system that allows its use in the RASODOCCIA + FILODOCCIA system.











# SCHEDA TECNICA

CABINA DOCCIA	
ALTEZZA STANDARD	h. 1976 mm
SPESSORE DEI VETRI	8 mm
MANIGLIA	PIVOT: 198 mm SLIDING: 580 mm
ALTEZZA SCAVO NEL PAVIMENTO	155 mm
PROTECTIVE	incluso
TEMPI DI SPEDIZIONE	4-5 settimane
FINITURE DISPONIBILI	
FINITURE VETRO	vetro temperato trasparente
	vetro temperato fumè
	vetro temperato extra-chiaro
FINITURE DOGHE	alluminio bianco
	alluminio nero
	legno iroko legno teak
FINITURE PROFILO	alluminio bianco opaco
	alluminio nero opaco
	alluminio cromo brillante
COLONNA DOCCIA	alluminio cromo brillante

SHOWER ENCLOSURE	
HEIGHT STANDARD	h. 1976 mm
GLASS THICKNESS	8 mm
HANDLE	PIVOT: 198 mm SLIDING: 580 mm
HEIGHT EXCAVATION IN THE FLOOR	155 mm
PROTECTIVE	included
DELIVERY TIME	4-5 weeks
AVAILABLE FINISHES	
GLASS FINISHES	transparent tempered glass
	fumè tempered glass
	extra-clear tempered glass
SLAT FINISHES	aluminum White
	aluminum Black
	Wood iroko
	Wood teak
PROFILE FINISHES	matt White aluminum
	matt Black aluminum
	bright chrome aluminum
SHOWER COLUMN	bright chrome aluminum

# TECHNICAL FEATURES

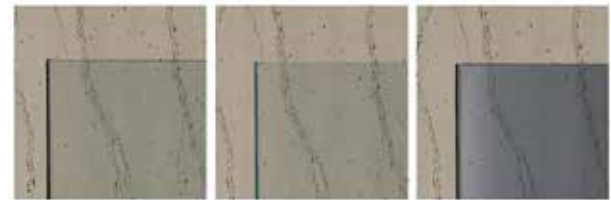

## FINITURE VETRO:

RASODOCCIA e FILODOCCIA utilizzano per porte e lati fissi, lastre di vetro temperato da 8 mm, nei colori trasparente, extra chiaro e fumè, con trattamento Protective Glass di serie

## GLASS FINISHES:

RASODOCCIA and FILODOCCIA use 8 mm thick tempered glass panels for doors and walls, in transparent, extra clear, and smoked colors, with Protective Glass treatment as standard.



## FINITURE DOGHE:

Doghe in alluminio verniciato in bianco o nero antracite, oppure in legno massello Iroko o Teak.

## SLAT FINISHES:

Slats in aluminum painted white or anthracite black, or in solid Iroko or Teak wood.

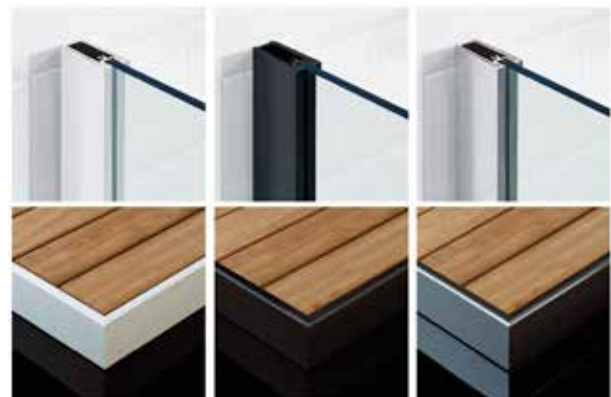

## FINITURE PROFILI:

Tutti i profili (piatto+cabina) sono realizzati in alluminio verniciati di colore bianco o nero antracite, oppure in argento lucido.

## PROFILE FINISHES:

All profiles (plate+cabin) are made of aluminum painted in white or anthracite black, or in polished silver.

## SCORREVOLI / SLIDING

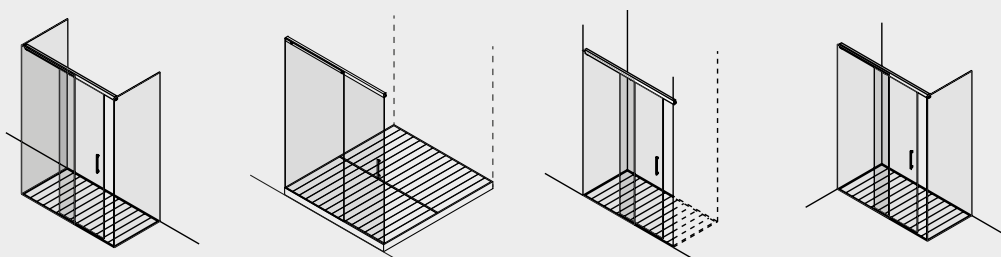

## BATTENTI / PIVOT

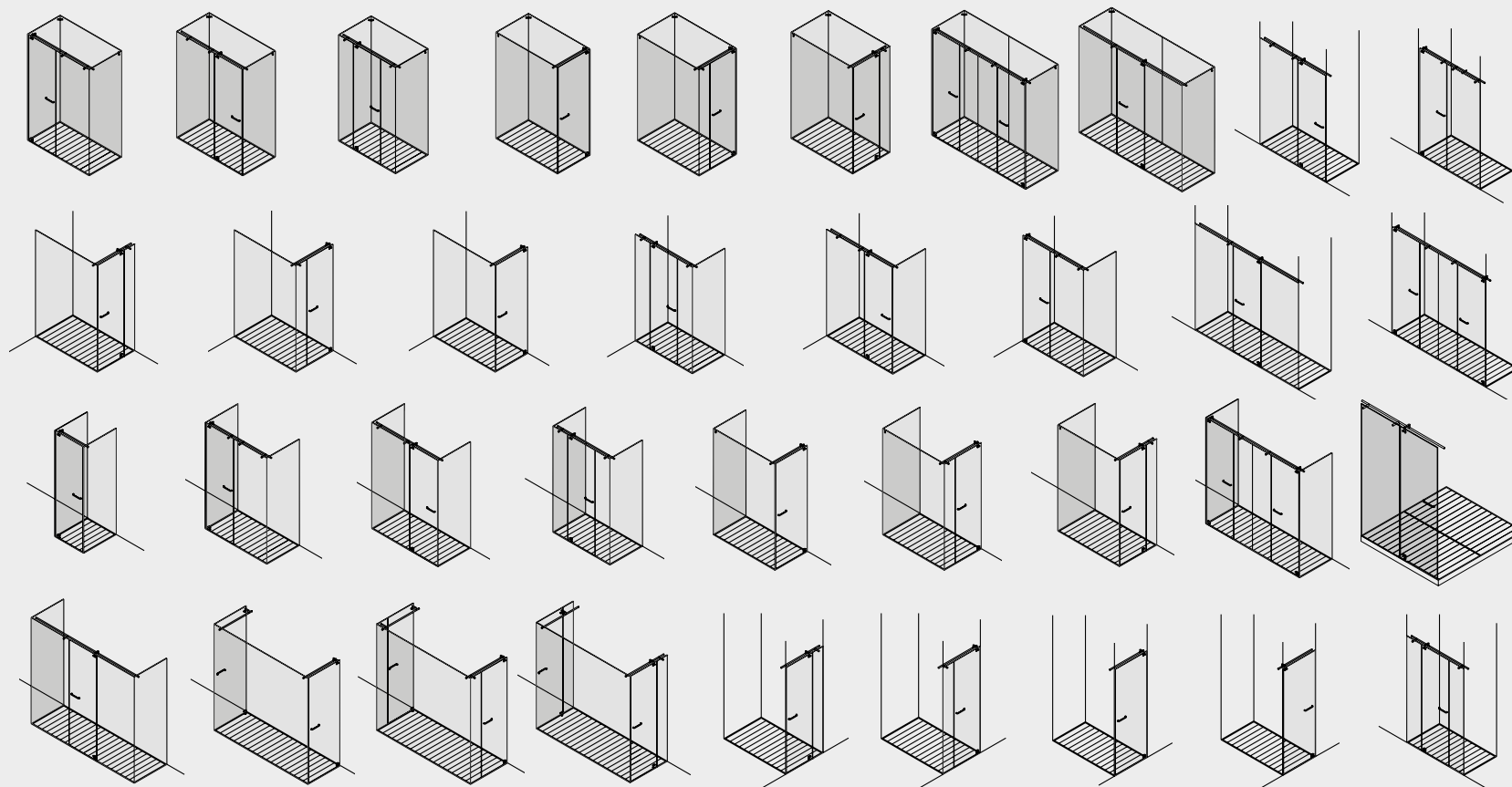

## SEPARÈ / WALK-IN

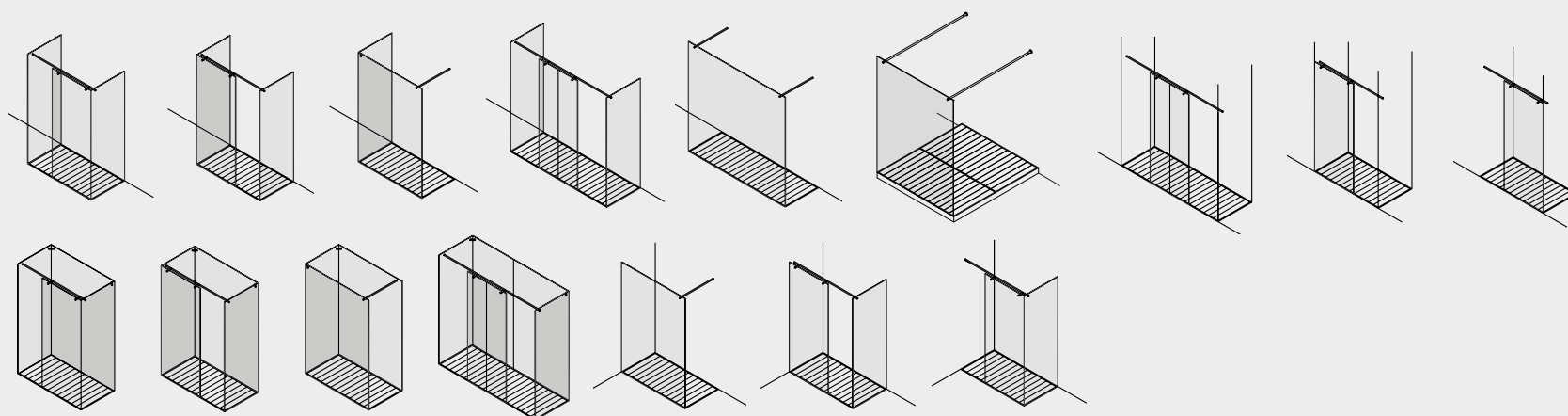



**FILODOCCIA**  
SHOWER

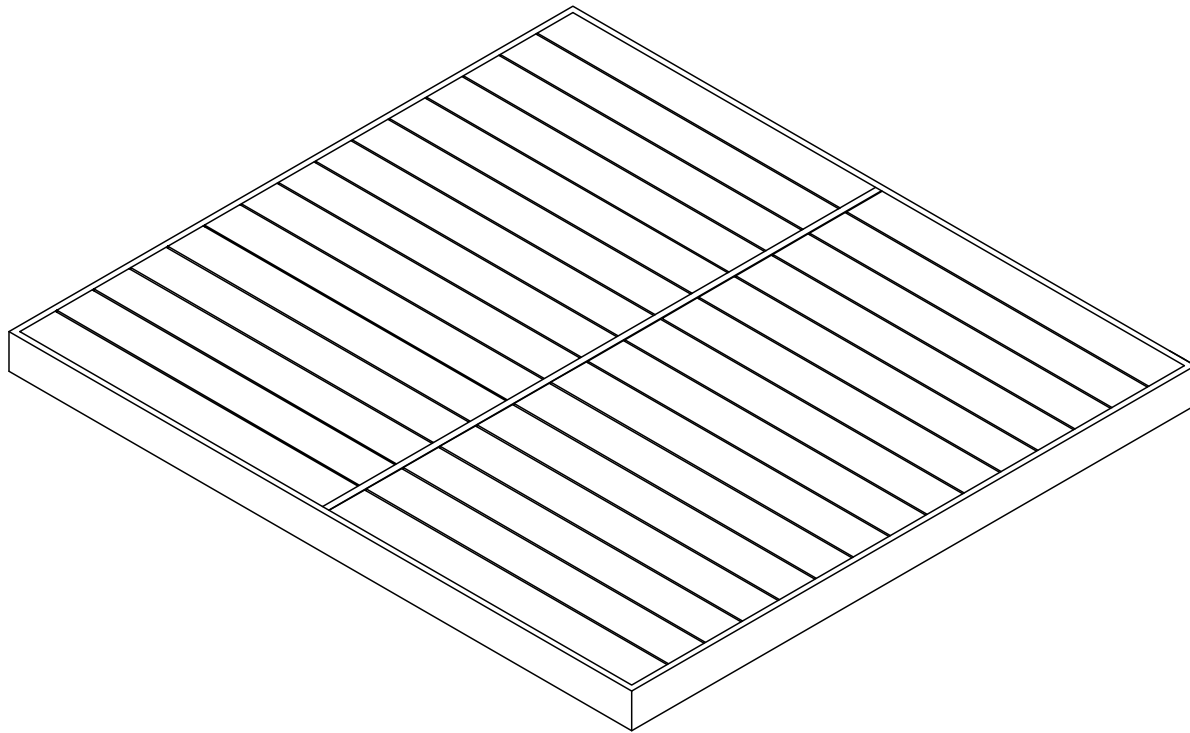

**Filodoccia** è il medesimo sistema Rasodoccia pensato per tutte quelle situazioni ove non sia possibile, a causa dello spazio insufficiente nel massetto, installare un sistema Rasodoccia.

È pensato per essere applicato sopra un pavimento finito. Il piatto è composto da un telaio in alluminio e una vasca di raccolta acqua coperta da una sequenza di doghe in essenza (legno iroko o teak) o in alluminio (bianco o nero); le doghe rappresentano il piano calpestabile del piatto. Lo speciale profilo perimetrale permette la possibilità di inserire, nei vari lati del piatto, lastre in vetro temperato di sicurezza 8 mm che possono essere trasparenti, extra chiare o fumè. larghezze (da 82,8 cm a 403,2 cm) combinabili con sei profondità (da 70 cm a 95 cm).

**Filodoccia** is the same Rasodoccia system designed for all situations where it is not possible, due to insufficient space in the screed, to install a Rasodoccia system.

It is designed to be applied over a finished floor. The tray consists of an aluminum frame and a water collection basin covered by a sequence of slats in wood (iroko or teak) or aluminum (white or black); the slats represent the walkable surface of the tray. The special perimeter profile allows for the possibility of inserting, on the various sides of the tray, 8 mm tempered safety glass panes that can be transparent, extra clear, or smoked widths (from 82.8 cm to 403.2 cm) that can be combined with six depths (from 70 cm to 95 cm).



# LUSSUOSO E RAFFINATO

QUESTO TIPO DI VETRO CREA  
UN'ATMOSFERA ESCLUSIVA A CUI È DIFFICILE  
RESISTERE.

Il modello Filodoccia con porta centrale battente si presenta come un modello di tendenza grazie alla scelta del vetro fumè, che sta prendendo sempre più piede nel mondo dell'interior design. Oltre al vetro, Filodoccia, è unico nel suo genere grazie al piatto intelaiato in alluminio e una vasca di raccolta acqua, coperta da una sequenza di doghe in essenza di legno Iroko, che costituisce il piano calpestabile del piatto.

Nell'insieme Filodoccia si può definire il prodotto di design che tutti vorrebbero avere nel proprio bagno per creare quel tocco di raffinatezza ed eleganza.

# LUXURIOUS AND REFINED

THIS TYPE OF GLASS CREATES AN EXCLUSIVE  
ATMOSPHERE THAT IS HARD TO RESIST.

The Filodoccia model with a central hinged door is trendy thanks to the choice of smoked glass, which is becoming increasingly popular in the world of interior design. In addition to the glass, Filodoccia is unique thanks to the aluminum-framed tray and a water collection tank, covered by a sequence of Iroko wood slats, which form the walkable surface of the tray.

All in all, Filodoccia can be defined as the design product that everyone would like to have in their bathroom to create that touch of refinement and elegance.





Spaart by Megius da anni interpreta al meglio gli scenari legati all'ambiente bagno del futuro, attraverso idee, progetti, prodotti: con la forza della trasformazione. Nasce quindi il progetto RASODOCCIA® - FILODOCCIA®, un sistema modulare in cui piatto e cabina sono integrati in un monoblocco dall'alto contenuto estetico e funzionale.

Spaart by Megius has been interpreting the scenarios of the bathroom of the future for years, through ideas, projects, and products: with the power of transformation. This is how the RASODOCCIA® - FILODOCCIA® project was born, a modular system in which the shower tray and cabin are integrated with a single block with a high aesthetic and functional content.



È il primo sistema dove la cabina doccia si incassa nel piatto, creando una struttura integrata formata da più materiali, fusi in un unico elemento.

Il telaio è composto da un telaio in alluminio e una vasca di raccolta acqua coperta da doghe in legno o alluminio, che costituiscono il piano calpestabile della doccia.

Il profilo perimetrale permette l'abbinamento su ogni lato della vasca con differenti tipologie di lastre in vetro temperato 8mm nei colori trasparente, extrachiaro e fumè. Le facciate in cristallo possono essere accessoriate con porte a battente ad apertura esterna.

It is the first system where the shower enclosure is recessed into the tray, creating an integrated structure made of several materials, fused into a single element.

The frame consists of an aluminium frame and a water collection tank covered by wooden or aluminium slats, which form the walkable surface of the shower.

The perimeter profile allows the combination on each side of the tub with different types of 8mm tempered glass panels in transparent, extra-clear and smoked colours. The glass fronts can be fitted with hinged doors that open outwards.





FILODOCCIA è disponibile in 30 larghezze (da 828 a 4032 mm) combinabili con 6 profondità (da 700 a 950 mm). L'inserimento di un profilo sotto al rivestimento a parete, comporta la perdita di 12 mm rispetto le dimensioni normali del piatto e della cabina.

FILODOCCIA is available in 30 widths (828 to 4032 mm) that can be combined with 6 depths (700 to 950 mm). The insertion of a profile underneath the wall covering results in the loss of 12 mm in relation to the normal dimensions of the tray and the cabin.

I sistemi RASODOCCIA / FILODOCCIA, offrono la possibilità di inserire una colonna con alimentazione direttamente dal piatto doccia e relativo miscelatore termostatico. E' possibile associare il sistema anche con una semi-colonna con soffione a parete o solamente con un soffione e miscelatore.

The RASODOCCIA / FILODOCCIA systems offer the possibility of inserting a column fed directly from the shower tray and a thermostatic mixer. It is also possible to combine the system with a semi-column with wall-mounted shower head or just with a shower head and mixer.







## SCHEDA TECNICA

## TECHNICAL FEATURES

CABINA DOCCIA	
ALTEZZA STANDARD	h. 2050 mm
SPESSORE DEI VETRI	8 mm
MANIGLIA	PIVOT: 198 mm SLIDING: 580 mm
ALTEZZA SCAVO NEL PAVIMENTO	80 mm
PROTECTIVE	incluso
TEMPI DI SPEDIZIONE	4-5 settimane

FINITURE DISPONIBILI	
FINITURE VETRO	vetro temperato trasparente
	vetro temperato fumè
	vetro temperato extra-chiaro
FINITURE DOGHE	alluminio bianco
	alluminio nero
	legno iroko
FINITURE PROFILO	legno teak
	alluminio bianco opaco
	alluminio nero opaco
COLONNA DOCCIA	alluminio cromo brillante

SHOWER ENCLOSURE	
HEIGHT STANDARD	h. 2050 mm
GLASS THICKNESS	8 mm
HANDLE	PIVOT: 198 mm SLIDING: 580 mm
HEIGHT EXCAVATION IN THE FLOOR	80 mm
PROTECTIVE	included
DELIVERY TIME	4-5 weeks

AVAILABLE FINISHES	
GLASS FINISHES	transparent tempered glass
	fumè tempered glass
	extra-clear tempered glass
SLAT FINISHES	aluminum White
	aluminum Black
	Wood iroko
PROFILE FINISHES	Wood teak
	matt White aluminum
	matt Black aluminum
SHOWER COLUMN	bright chrome aluminum

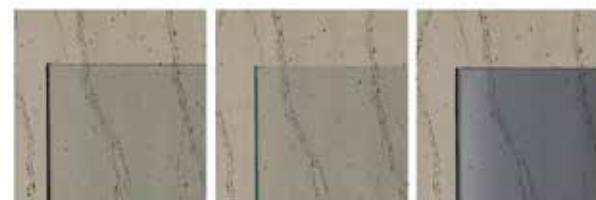

**FINITURE VETRO:**  
RASODOCCIA e FILODOCCIA utilizzano per porte e lati fissi, lastre di vetro temperato da 8 mm, nei colori trasparente, extra chiaro e fumè, con trattamento Protective Glass di serie

**GLASS FINISHES:**  
RASODOCCIA and FILODOCCIA use 8 mm thick tempered glass panels for doors and walls, in transparent, extra clear, and smoked colors, with Protective Glass treatment as standard.



**FINITURE DOGHE:**  
Doghe in alluminio verniciato in bianco o nero antracite, oppure in legno massello Iroko o Teak.

**SLAT FINISHES:**  
Slats in aluminum painted white or anthracite black, or in solid Iroko or Teak wood.

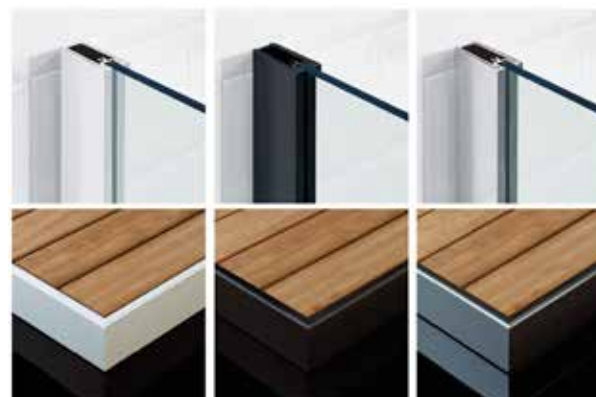

**FINITURE PROFILI:**  
Tutti i profili (piatto+cabina) sono realizzati in alluminio verniciati di colore bianco o nero antracite, oppure in argento lucido.

**PROFILE FINISHES:**  
All profiles (plate+cabin) are made of aluminum painted in white or anthracite black, or in polished silver.

## SCORREVOLI / SLIDING

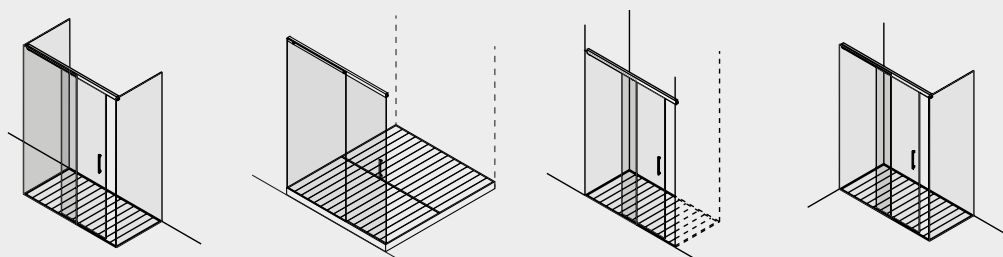

## BATTENTI / PIVOT

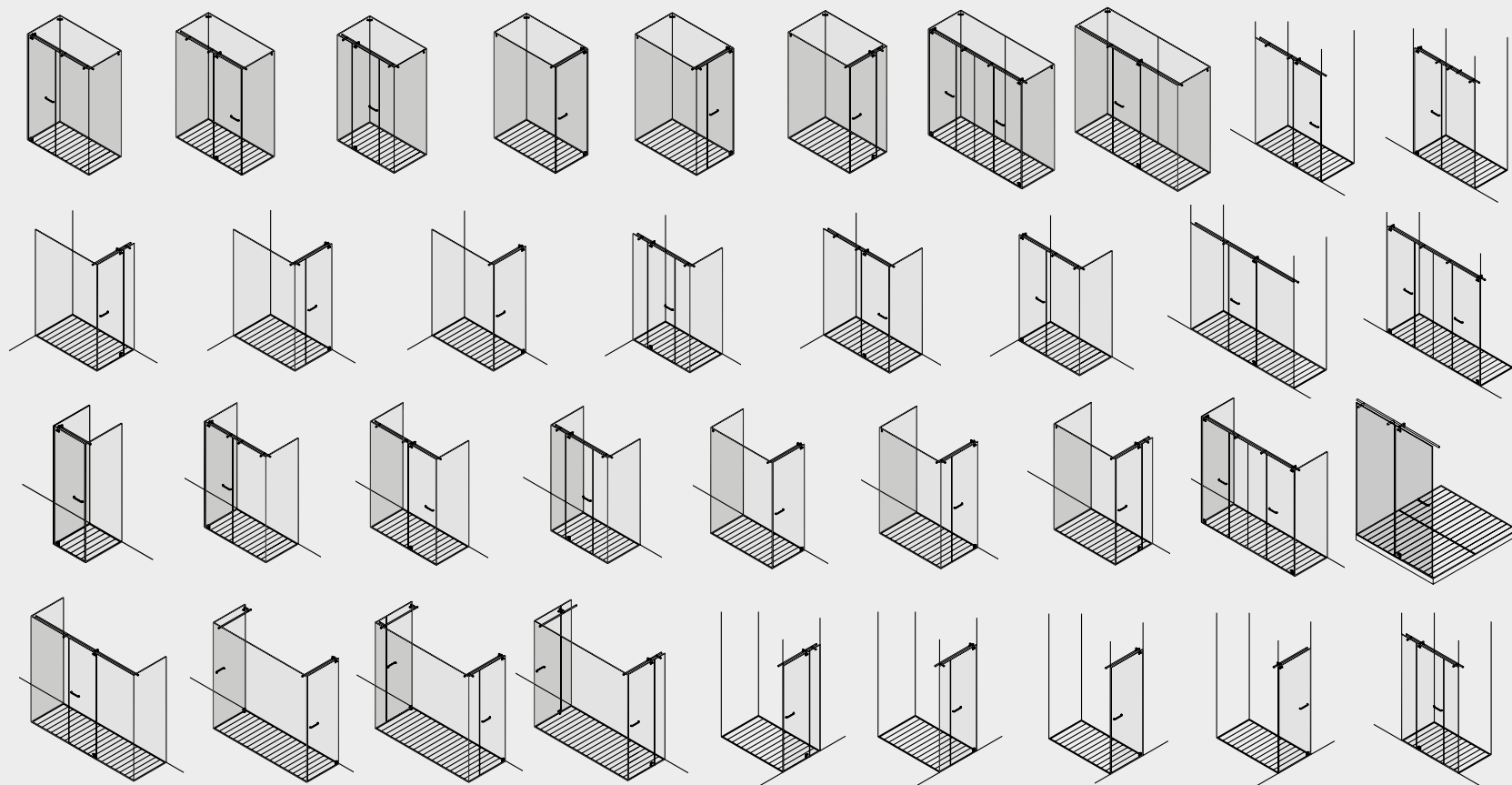

## SEPARÈ / WALK-IN

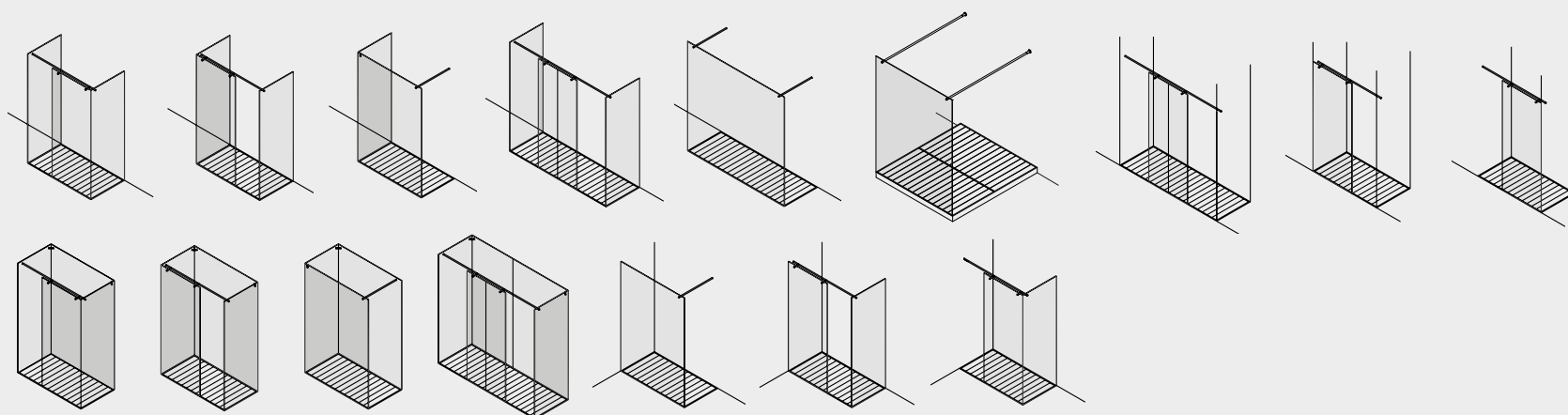

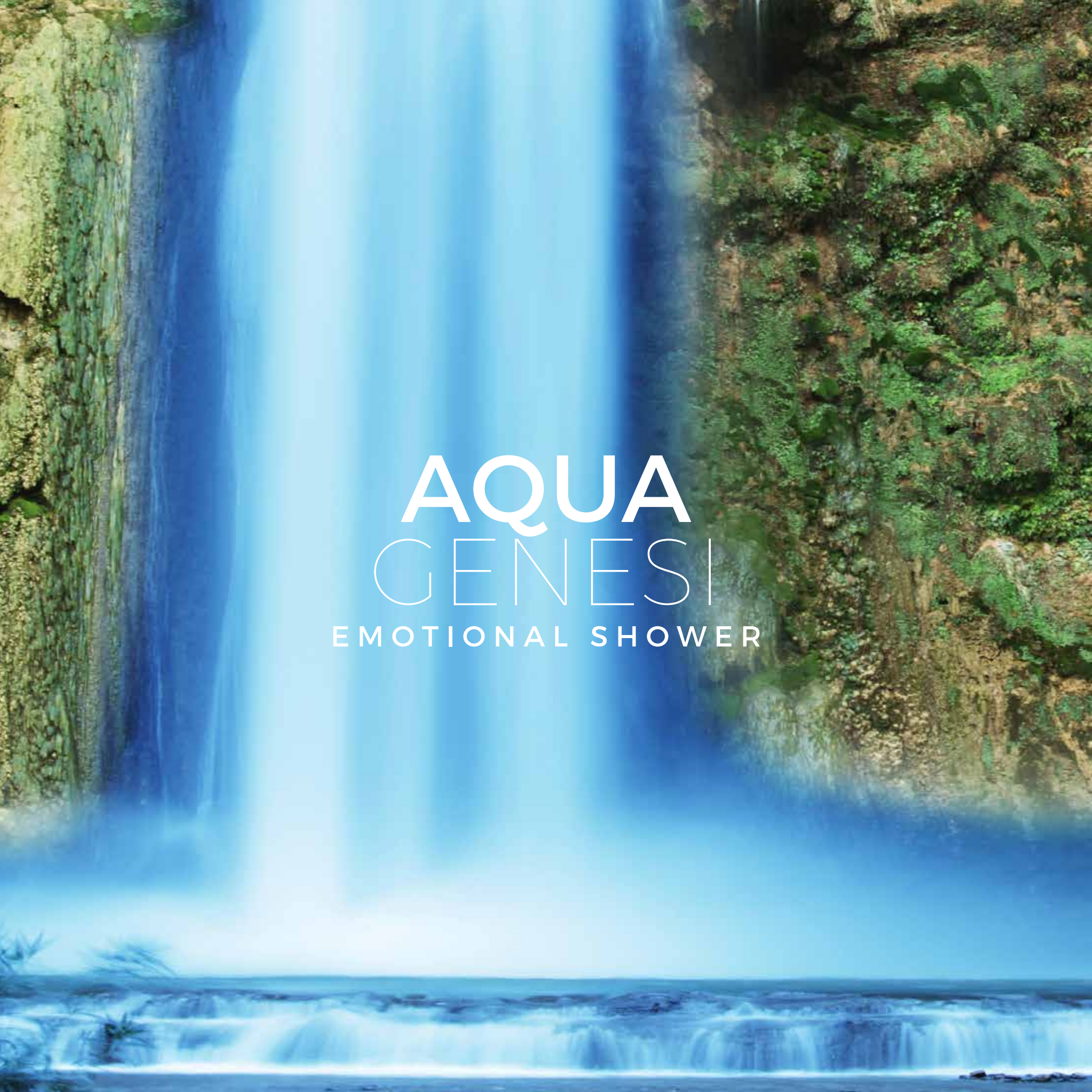

**AQUA**  
GENESI  
EMOTIONAL SHOWER



L'acqua e la velocità, fisica applicata al benessere: infiniti modi di essere ricevere stimolazioni benefiche dall'acqua calda e fredda per una totale rigenerazione del corpo.

Queste pratiche rientrano nel più ampio spettro dell'idroterapia, che è uno dei più antichi metodi di cura, e si avvale del mezzo più semplice e più comune in natura: l'acqua. L'acqua, scorrendo sulla superficie del corpo o sommergendolo, tonifica, dà vigore, sollecita la reazione dell'intero organismo.

Water and speed, physics applied to wellbeing: infinite ways of receiving beneficial stimulation from hot and cold water for total regeneration of the body.

These practices fall within the broader spectrum of hydrotherapy, which is one of the oldest methods of treatment, and uses the simplest and most common medium in nature: water. Water, flowing over the surface of the body or submerging it, invigorates, invigorates and stimulates the reaction of the entire organism.

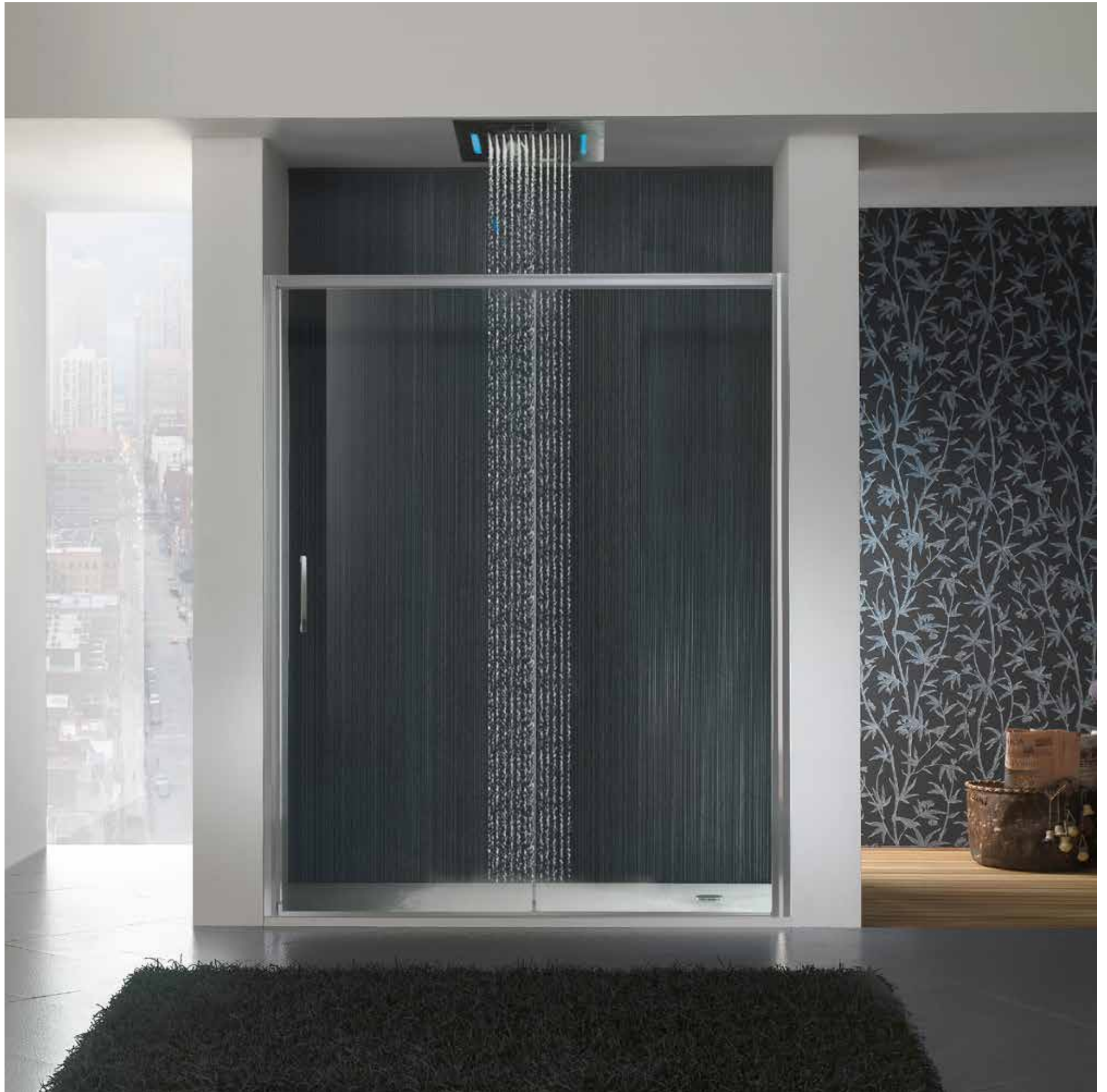



Stimolazioni attraverso cascata d'acqua, nebbia tropicale, soffione a pioggia, acqua a caduta variabile ad una o 3 spirali

Stimulations through water cascades, tropical fog, rain showerheads, variable fall water with one or 3 spirals





# SIMBIOSI TRA ACQUA, COLORE E SUONO

Fusione perfetta tra acqua, luce e design. Il progetto Aqua Genesi comprende una gamma di soffioni cromoterapia componibili, realizzati in acciaio inox supermirror. La soluzione ideale per un benessere disegnato secondo i propri desideri, un concept innovativo che rompe gli schemi tradizionali creando nuove forme e percorsi.

# SYMBIOSIS OF WATER, COLOUR AND SOUND

The Perfect fusion of water, light and design. The Aqua Genesi project includes a range of modular chromotherapy shower heads made of supermirror stainless steel. The ideal solution for wellness is designed according to your desires, an innovative concept that breaks the traditional schemes creating new shapes and paths.









## AQUAGENESI 01



DIMENSIONI SOFFIONE	500x500 mm
MATERIALE	acciaio inox
FINITURE	specchio
TEMPI DI SPEDIZIONE	4-5 settimane

\*altre finiture colore disponibili

## FUNZIONI INCLUSE



Getto pioggia Wire

DIMENSIONS	500x500 mm
MATERIAL	stainless steel
FINISHES	mirror
DELIVERY TIME	4-5 weeks

\*other color finishes available

## FUNCTIONS INCLUDED



Rain jet Wire

## AQUAGENESI 04



DIMENSIONI SOFFIONE	630x480 mm
MATERIALE	acciaio inox
FINITURE	specchio
TEMPI DI SPEDIZIONE	4-5 settimane

\*altre finiture colore disponibili

## FUNZIONI INCLUSE



Getto pioggia Spin Cascata

DIMENSIONS	630x480 mm
MATERIAL	stainless steel
FINISHES	mirror
DELIVERY TIME	4-5 weeks

\*other color finishes available

## FUNCTIONS INCLUDED



Rain jet Spin Waterfall

## AQUAGENESI 04 CROMO



DIMENSIONI SOFFIONE	630x480 mm
MATERIALE	acciaio inox
FINITURE	specchio
TEMPI DI SPEDIZIONE	4-5 settimane

\*altre finiture colore disponibili

## FUNZIONI INCLUSE



Getto pioggia Spin Cascata Cromoterapia con telecomando

DIMENSIONS	630x480 mm
MATERIAL	stainless steel
FINISHES	mirror
DELIVERY TIME	4-5 weeks

\*other color finishes available

## FUNCTIONS INCLUDED



Rain jet Spin Waterfall Chromotherapy with remote control

## AQUAGENESI 05 CROMO &amp; SOUND



## AQUAGENESI 06 CROMO

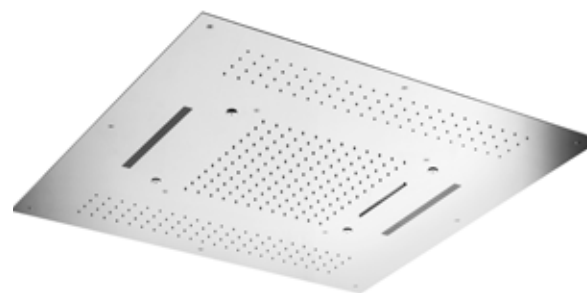

DIMENSIONI SOFFIONE	480x630 mm
MATERIALE	acciaio inox
FINITURE	specchio
TEMPI DI SPEDIZIONE	4-5 settimane

\*altre finiture colore disponibili

DIMENSIONS	480x630 mm
MATERIAL	stainless steel
FINISHES	mirror
DELIVERY TIME	4-5 weeks

\*other color finishes available

## FUNZIONI INCLUSE



Getto pioggia



Sistema audio incluso



Bluetooth



Cromoterapia con telecomando



Mist

## FUNCTIONS INCLUDED



Rain jet



System audio included



Bluetooth



Chromotherapy with remote control



Mist

DIMENSIONI SOFFIONE	950x950 mm
MATERIALE	acciaio inox
FINITURE	specchio
TEMPI DI SPEDIZIONE	4-5 settimane

\*altre finiture colore disponibili

DIMENSIONS	950x950 mm
MATERIAL	stainless steel
FINISHES	mirror
DELIVERY TIME	4-5 weeks

\*other color finishes available

## FUNZIONI INCLUSE



Getto pioggia



Doppio effetto pioggia



Cascata



Cromoterapia con telecomando



Mist

## FUNCTIONS INCLUDED



Rain jet



Double Rain jet



Waterfall



Chromotherapy with remote control



Mist



**BUCKET**  
SHOWER  
EMOTIONAL SHOWER



**Bucket Shower** è la doccia di contrasto per eccellenza, da effettuare dopo essere usciti dalla sauna o dal bagno turco;

Si tratta di un un secchio in larice durevole nel quale è racchiusa all'interno l'acqua.

**Bucket Shower** is the contrast shower par excellence, to be used after leaving the sauna or Turkish bath;

It is a durable larch wood bucket in which water is stored.





### In cosa consiste la tradizionale il Bucket Shower?

È una sorta di doccia che prevede, in modo improvviso, che un getto di acqua gelata contenuto in un secchio "appeso" al soffitto venga rovesciato e versato sul corpo dopo aver tirato una catenella, in modo da creare uno shock termico per l'organismo talmente forte da irrobustirlo. Il momento ideale per effettuarlo è immediatamente dopo una seduta di sauna, quando il corpo è ancora surriscaldato, in modo da sfruttare al massimo lo shock termico.

### What is the traditional Bucket Shower??

It is a kind of shower in which a jet of ice-cold water contained in a bucket "hanging" from the ceiling is suddenly tipped over and poured over the body after pulling a chain, to create such a strong thermal shock to the body that it strengthens it. The ideal time to do this is immediately after a sauna session when the body is still overheated, to make the most of the thermal shock.



DIMENSIONI	510x500 mm
CAPACITÀ ACQUA	7,5 lt.
INSTALLAZIONE	parete / soffitto
LUNGHEZZA CATENA	73 cm
KIT FISSAGGIO A PARETE	acciaio inox
TEMPI DI SPEDIZIONE	4-5 settimane

DIMENSIONS	510x500 mm
WATER CAPACITY	7,5 lt.
APPLICATION	wall / ceiling
CHAIN LENGTH	73 cm
WALL MOUNTING KIT	stainless steel
DELIVERY TIME	4-5 weeks



Le immagini, i dati e le informazioni contenuti nel presente catalogo sono da ritenersi indicativi e possono subire variazioni anche senza alcun preavviso.

Megius S.p.A.: tutti i diritti riservati, ogni riproduzioni totale o parziale dei contenuti del presente catalogo, sia di testo che immagini, è vietata e sarà perseguibile a termini di legge.

The images and data contained in this catalogue are merely a guide and may be changed at any time without notice.

Megius S.p.A.: all rights reserved, total or partial reproduction of the text or illustrations in this catalogue is prohibited and subject to legal sanctions.

[www.megius.com](http://www.megius.com)