

/

**WARDROBES
COLLECTION**

project
+design Studio

/ WARDROBES COLLECTION

Infinite Space

 COMPOSIT®

FR Notre histoire est une histoire de famille typiquement italienne, dans laquelle l'engagement pour le développement de produits industriels avec un «cœur artisanal» est le fil conducteur qui lie tous les différents moments du développement de l'entreprise. Composit a vu se succéder trois générations de la famille Belligotti, pour devenir aujourd'hui une marque de niveau international. Passion, Engagement, Innovation, Recherche, Investissements, Matériaux, Technologie, Fiabilité, Style, Design sont les différents éléments qui constituent l'âme d'une cuisine Composit. Dans chaque modèle, tous ces facteurs cohabitent avec l'expérience des personnes qui travaillent avec nous: patrimoine de Composit sont tous les collaborateurs qui travaillent en Italie et à l'étranger. Recherche et mise à jour, capacité de dialogue et de collaboration, assistance continue sont à la base des relations de Composit avec les clients, architectes et détaillants. Ceux que se tournent vers nous peuvent trouver du personnel disponible et des réponses adéquates à tous leurs besoins, garanties par la fiabilité d'une entreprise avec une grande expérience.

ES La nuestra es una típica historia de familia italiana en la que la dedicación por el desarrollo de productos industriales con 'corazón artesano' es el hilo común que une todos los diferentes momentos del desarrollo de la empresa. Composit ha visto suceder a tres generaciones de la familia Belligotti, para convertirse hoy en una realidad a nivel internacional. Pasión, Compromiso, Innovación, Investigación, Inversiones, Materiales, Tecnología, Fiabilidad, Estilo, Diseño son los diversos factores que componen el alma de una cocina Composit. En cada modelo conviven todos estos factores y la experiencia de las personas que trabajan con nosotros: el patrimonio de Composit son todos los colaboradores que trabajan en Italia y en el extranjero. La investigación y actualización, la capacidad de diálogo y colaboración, la asistencia continua son la base de las relaciones de Composit con los clientes, arquitectos y minoristas encuentran en Composit personal disponible y respuestas adecuadas a todas sus necesidades, garantizando la fiabilidad de una empresa con gran experiencia.



ABOUT COMPOSIT

La nostra è una tipica storia italiana di famiglia in cui l'impegno nello sviluppo di prodotti industriali con un 'cuore artigianale' è il fil rouge che lega tutti i diversi momenti dello sviluppo dell'azienda.

Composit ha visto susseguirsi tre generazioni della famiglia Belligotti, fino a diventare oggi una realtà di livello internazionale.

Passione, Impegno, Innovazione, Ricerca, Investimenti, Materiali, Tecnologia, Affidabilità, Stile, Design sono i diversi fattori che costituiscono l'anima di Composit.

In ogni progetto convivono tutti questi fattori e l'esperienza delle persone che lavorano con noi: patrimonio di Composit sono tutti i collaboratori che lavorano in Italia e all'estero.

Ricerca e aggiornamento, capacità di dialogo e collaborazione, continua assistenza sono alla base delle relazioni di Composit con clienti, architetti e rivenditori che trovano da noi personale disponibile e risposte adeguate a tutte le loro esigenze, a garanzia della affidabilità di un'azienda con grande esperienza.

EN Ours is a typical Italian family story in which the commitment to the development of industrial products with an 'artisan heart' is the common thread that binds all the different moments of the company's development. Composit has seen three generations of the Belligotti family follow one another, to become today a reality of international level. Passion, Commitment, Innovation, Research, Investments, Materials, Technology, Reliability, Style, Design are the various factors that make up the soul of a Composit kitchen. In each model all these factors and the experience of the people who work with us coexist: Composit's assets are all the collaborators who work in Italy and abroad. Research and updating, capacity for dialogue and collaboration, continuous assistance are the basis of Composit's relationships with customers, architects and retailers who find us available personnel and adequate answers to all their needs, guaranteeing the reliability of a company with great experience.

1/ Flessibilità progettuale

Gli armadi sono realizzati su misura senza maggiorazione di prezzo

2/ Materiali di qualità

Ferramenta Blum, Cerniere ammortizzate,
Cassettiere a estrazione totale, finiture e materiali pregiati

3/ Solidità e robustezza

Pannelli in forte spessore per garantire robustezza e solidità:
Fianchi 25 mm / Ripiani 35 mm / Ante 22 mm / Schienali 8 mm

4/ Ampia gamma di finiture

La collezione armadi nasce con un'amplissima gamma di finiture riprese dal programma Kitchens Collection. Questo permette di creare un trait-d'union tra le zone della casa, Cucina, Living e Zona Notte.

why?

EN 1/ Design flexibility

The wardrobes are made to measure without a price increase

2/ Quality materials

Blum hardware, soft-closing hinges, full extension drawers, fine finishes and materials

3/ Solidity and robustness

Very thick panels to guarantee robustness and solidity:
Sides 25 mm / Shelves 35 mm / Doors 22 mm / Backs 8 mm

4/ Wide range of finishes

The wardrobe collection comes with a very wide range of finishes taken from the Kitchens Collection. This allows you to create a link between the areas of the house, kitchen, living room and night area.

FR 1/ Flexibilité de conception

Les armoires sont fabriquées sur mesure sans augmentation de prix.

2/ Matériaux de qualité

Tiroir Blum, charnières à fermeture douce, tiroirs à extension totale, finitions et matériaux de qualité.

3/ Solidité et robustesse

Panneaux très épais pour garantir la robustesse et la solidité :
Côtés 25 mm / Étagères 35 mm / Portes 22 mm / Arrières 8 mm

4/ Large gamme de finitions

La collection d'armoires propose une très large gamme de finitions issues du programme Kitchens Collection. Cela permet de créer un lien entre les différentes zones de la maison: Cuisine, Salon et Chambre.

ES 1/ Flexibilidad de diseño

Los armarios se fabrican a medida sin incremento de precio

2/ Materiales de calidad

Herrajes Blum, bisagras amortiguadas, cajoneras totalmente extraíbles, finos acabados y materiales

3/ Solidad y robustez

Paneles de gran espesor para garantizar robustez y solidez:
Lados 25 mm / Estantes 35 mm / Puertas 22 mm / Fondo 8 mm

4/ Amplia gama de acabados

La colección de armarios se creó con una amplísima gama de acabados extraídos del programa Colección Cocinas. Esto le permite crear un vínculo entre las áreas de la casa, la cocina, la sala living y el área de dormir.

 **COMPOSIT**

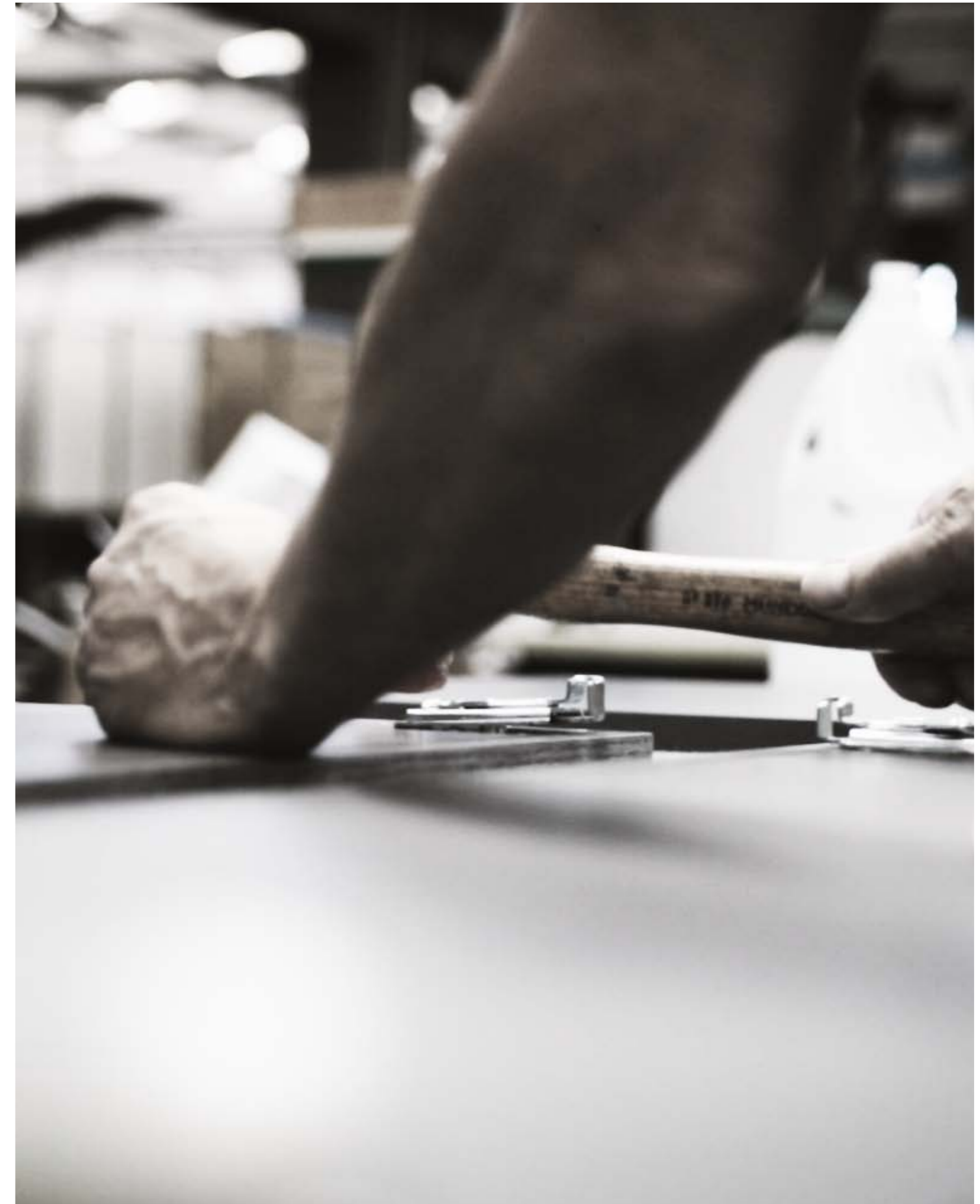

project
+design Studio

Tutta la purezza del design

01.

All the purity of design . Toute la pureté du design . Toda la pureza del diseño



1 Sablé RR . Sablé RR . Sablé RR . Sablé RR

2 Laccato opaco textured Bronzo YBRO . Bronze YBRO textured matt lacquer . Laqué mat texturé Bronze YBRO . Lacado mate texturado Bronce YBRO

3 Telaio vetrina Argo / Vetro Bronzo V3 . Argo glass doors frame / Bronze V3 glass . Cadre vitrine Argo / Verre Bronze V3 . Marco vetrina Argo / Cristal Bronce V3

Le zone armadio si allargano, ampliano le proprie soluzioni per integrarsi sempre di più con lo stile e le funzioni della zona notte fino ad arrivare ad essere ambienti 'open air'. A fare la differenza è il design ma soprattutto il 'servizio personalizzato' per arrivare a creare spazi esclusivi al punto da sembrare scenografie domestiche dall'alto valore estetico.

EN The wardrobe areas are expanding, widening their solutions to integrate more and more with the style and functions of the sleeping area until they become 'open air' environments. What makes the difference is the design but above all the 'personalized service' to create exclusive spaces to the point of looking like domestic settings with a high aesthetic value.

FR Les zones de dressing s'élargissent, offrant des solutions toujours plus variées pour s'intégrer davantage au style et aux fonctions de la chambre, jusqu'à devenir de véritables espaces « ouverts ». Ce qui fait la différence, c'est le design, mais surtout le « service personnalisé » qui permet de créer des espaces exclusifs, au point de ressembler à des décors domestiques d'une grande valeur esthétique.

ES Las zonas de vestuario se amplían, ampliando sus soluciones para integrarse cada vez más con el estilo y funciones de la zona de noche hasta convertirse en ambientes 'open air'. Lo que marca la diferencia es el diseño pero sobre todo el 'servicio personalizado' para crear espacios exclusivos hasta el punto de parecer ambientes domésticos con un alto valor estético.





“

VOLUMI A
CONTRASTO IN
UN GIOCO DI
OPPOSTI

*CONTRASTING
VOLUMES IN
A GAME OF
OPPOSITES*

”

01.

Volumes en contraste dans un jeu d'opposés . Volúmenes contrastantes en un juego de opuestos











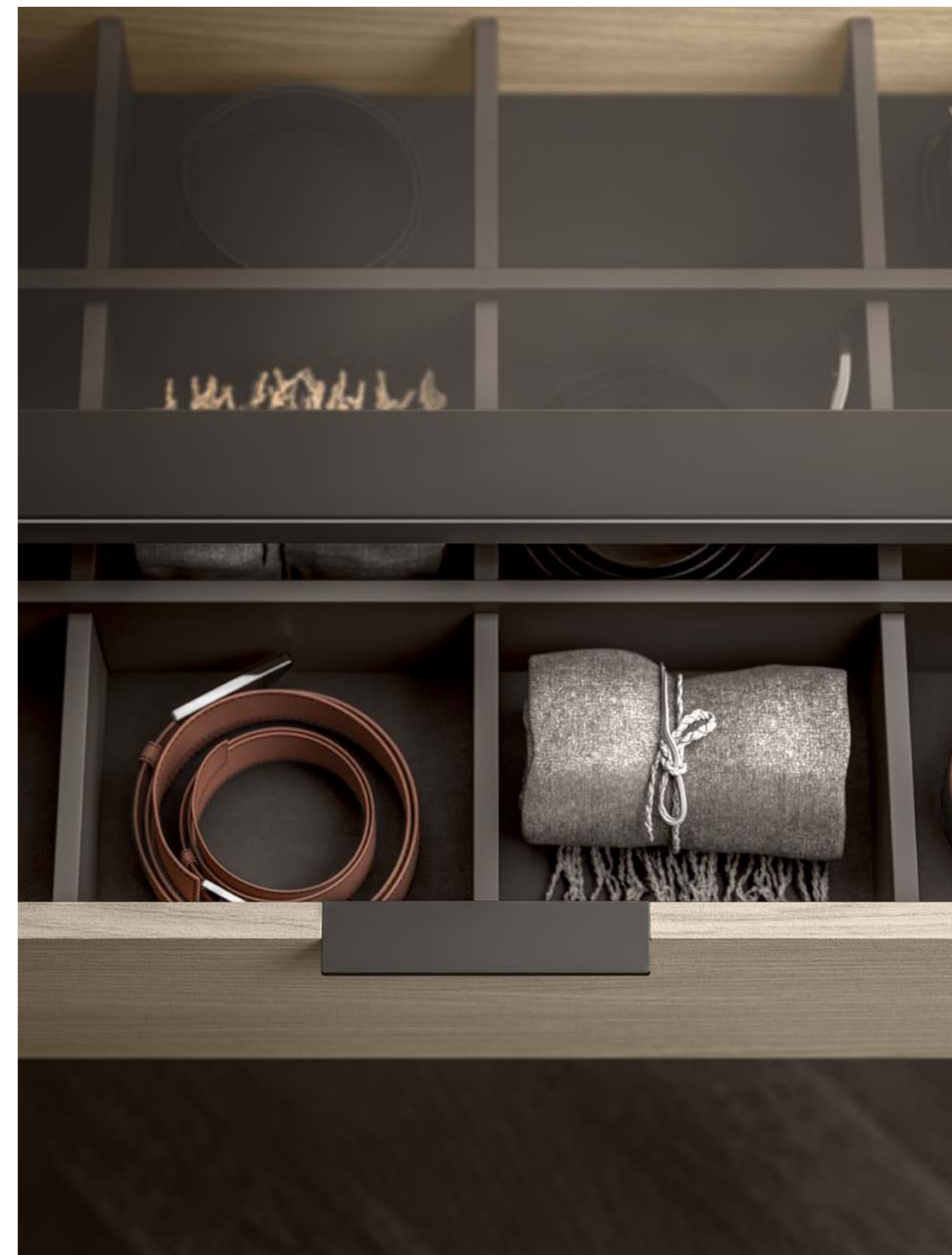

La vera personalizzazione è avvenuta nell'attrezzatura interna: isole polifunzionali, make-up area, pareti attrezzate. La zona armadio ha cambiato la propria progettualità, si è resa esteticamente bella, ricercata nelle finiture e nei materiali, arricchita di complementi lasciandosi alle spalle quella connotazione di 'stanza contenitore' che oggi non le calza più.

EN The real customization took place in the internal equipment: multifunctional islands, make-up area, equipped walls. The wardrobe room has changed its design, it has become aesthetically beautiful, refined in its finishes and materials, enriched with accessories, leaving behind that connotation of 'container room' which no longer fits it today.

FR La véritable personnalisation s'est réalisée dans l'équipement intérieur: îles multifonctionnelles, espace maquillage, murs aménagés. La zone de dressing a évolué dans sa conception, devenant esthétiquement belle, raffinée dans ses finitions et matériaux, enrichie de compléments, laissant derrière elle cette connotation de « pièce de stockage » qui ne lui correspond plus aujourd'hui.

ES La verdadera personalización se produjo en el equipamiento interno: islas multifuncionales, zona de maquillaje, paredes equipadas. La zona de vestuario ha cambiado de diseño, ha pasado a ser estéticamente bella, refinada en sus acabados y materiales, enriquecida con complementos, dejando atrás esa connotación de 'contain room' que hoy ya no le cabe.



project
+design Studio

L'ecceellenza delle superfici

V2.

The excellence of surfaces . L'excellence des surfaces . La excelencia de las superficies



1 Alpaca AA . Alpaca AA . Alpaca AA . Alpaca AA

2 Poro Noce CC . Poro Noce CC . Poro Noce CC . Poro Noce CC

3 Telaio vetrina Argo / Vetro Bronzo V3 . Argo glass doors frame / Bronze V3 glass . Cadre vitrine Argo / verre Bronze V3 . Marco vetrina Argo / Cristal Bronze V3



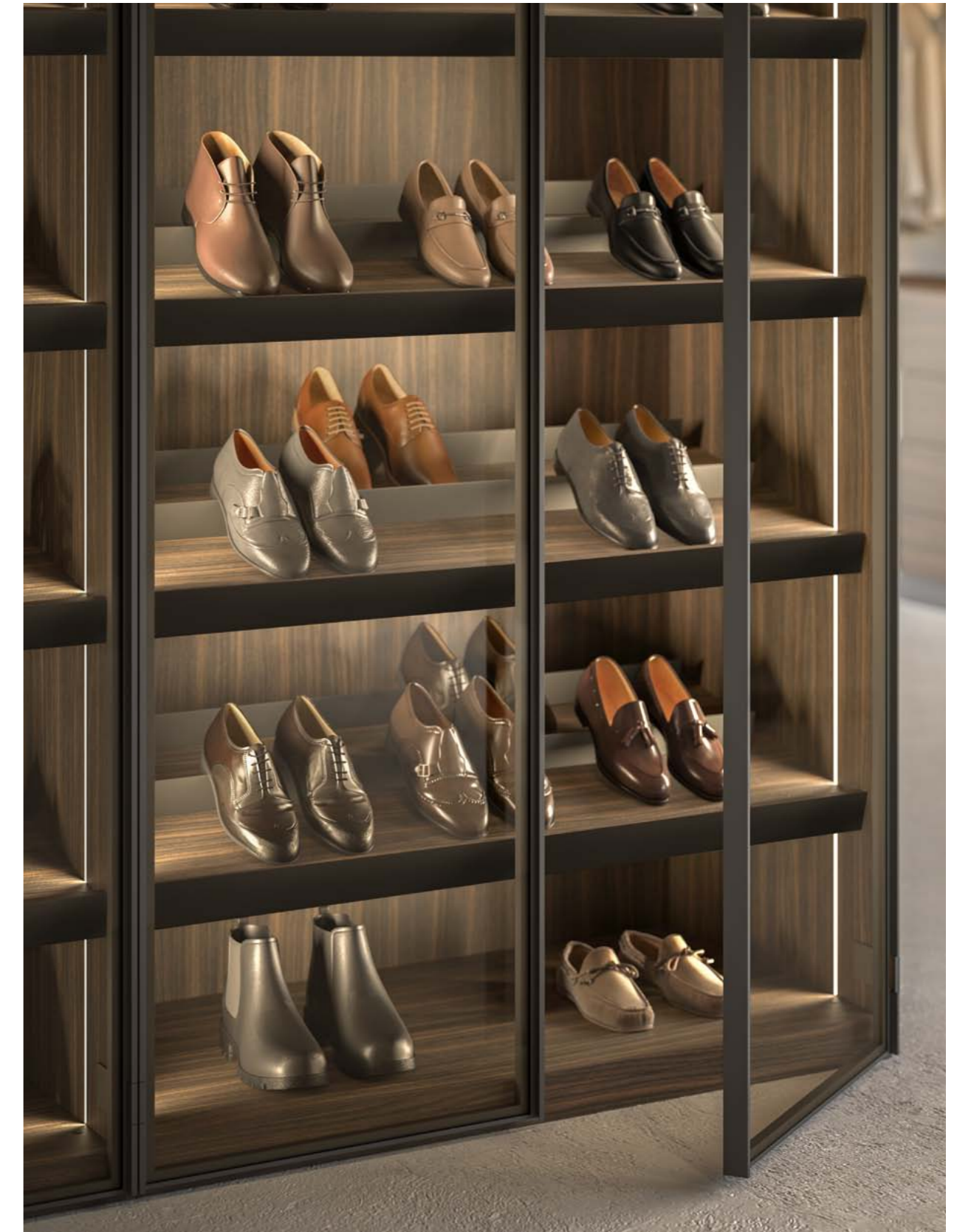

Il ritmo dell'abitare negli anni ha rivoluzionato l'estetica e la concezione degli spazi elevandoli a spazi di design con una forte valenza estetica.

Una configurazione di cabina armadio 'aperta' e integrata alla zona notte diventa il manifesto di un nuovo concetto di vita, trasparenze senza necessità di privacy in totale contatto con gli altri ambienti della casa.

EN The rhythm of living over the years has revolutionized the aesthetics and concept of spaces, elevating them to design spaces with a strong aesthetic value. An 'open' walk-in closet configuration integrated into the sleeping area becomes the manifesto of a new concept of life, transparencies without the need for privacy in total contact with the other rooms of the house.

FR Le rythme de l'habitat au fil des années a révolutionné l'esthétique et la conception des espaces, les élevant au rang d'espaces de design à forte valeur esthétique. Une configuration de dressing « ouvert » et intégré à la chambre devient le manifeste d'un nouveau concept de vie, des transparences sans nécessité de confidentialité, en total contact avec les autres espaces de la maison.

ES El ritmo de vida a lo largo de los años ha revolucionado la estética y el concepto de los espacios, elevándolos a diseñar espacios con un fuerte valor estético. Una configuración de vestidor 'abierto' integrado en la zona de noche se convierte en el manifesto de un nuevo concepto de vida, transparencias sin necesidad de privacidad en total contacto con el resto de estancias de la casa.





“
MULTITASKING.
FARE PIÙ COSE
NELLO STESSO
AMBIENTE
*MULTITASKING.
DOING MORE
THINGS IN THE
SAME
ENVIRONMENT*
”

02.



Multitâche. Pour faire plusieurs choses dans le même espace . Multitasking. Para hacer más cosas en el mismo entorno

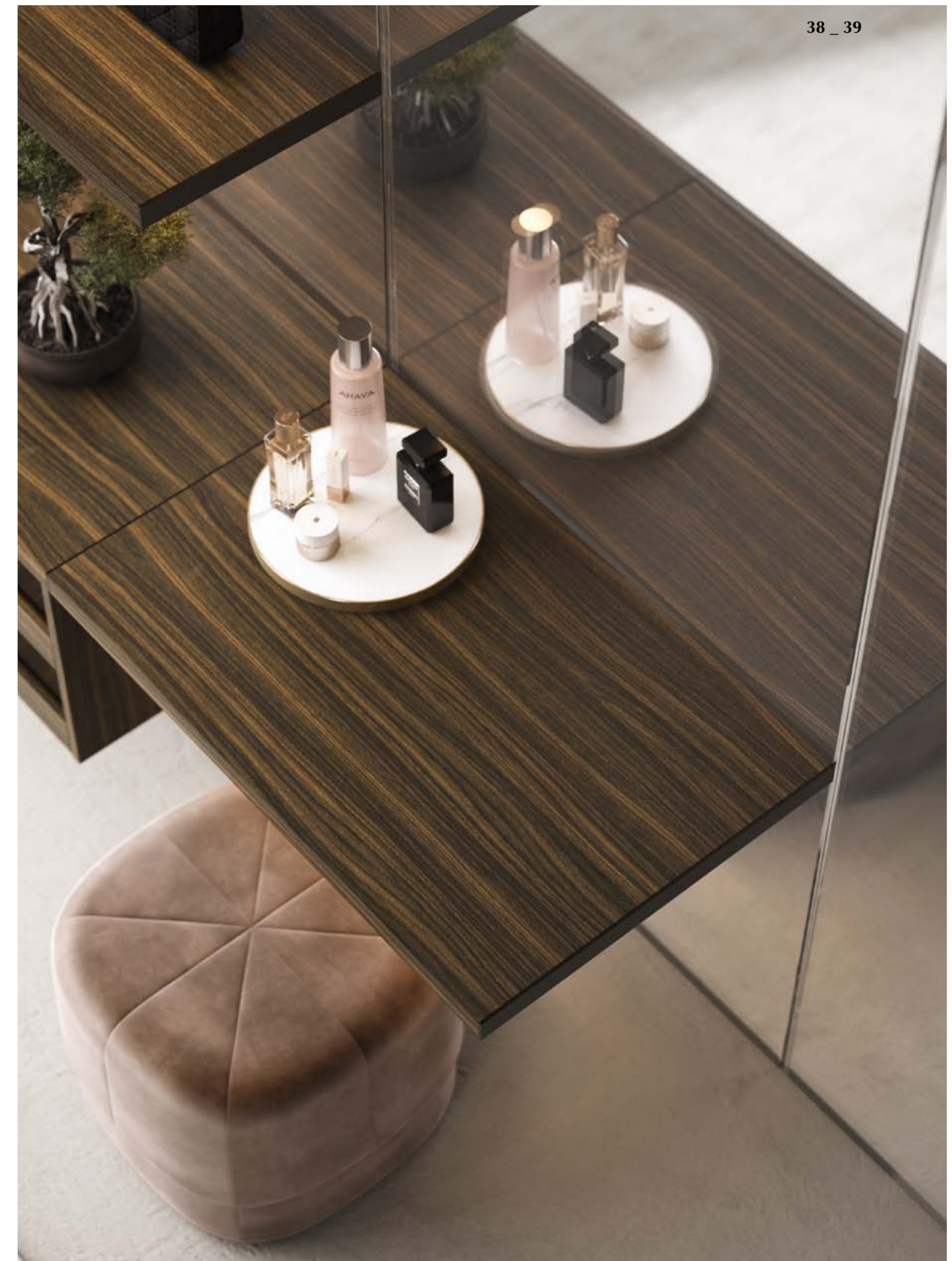



project
+design Studio

Oltre i confini dell'armadio

V3.

Beyond the boundaries of the wardrobe . Au-delà des frontières du dressing . Más allá de los límites del armario



1 Laccato opaco metallo effetto graffiato Grigio Ferro YGRF . Matt metal lacquer with scratched effect Iron Gray YGRF . Laqué mat métal Effet Gratté Gris Fer YGRF
Lacado metal mate efecto rayado Gris Hierro YGRF

2 Laccato opaco platino A08 . Matt lacquer A08 . Laqué mat A08 . Lacado mate A08

3 Canapa primo fiore PP . Primo Fiore PP . Primo Fiore PP . PP Primo Fiore

4 Telaio vetrina Argo / Vetro trasparente V4 . Argo glass doors frame / V4 transparent glass . Cadre vitrine Argo / verre transparent V4 . Marco vetrina Argo / Cristal transparente V4

Un unico grande ambiente accoglie cabina armadio e camera da letto con pareti che non sono barriere ma squarci verso la luminosità e la grandezza dello spazio notte. Ripensare il modo di organizzare lo spazio in camera da letto, è la vera rivoluzione. Le cabine armadio contemporanee devono rispettare le regole dello spazio ma, allo stesso tempo, si aprono alla zona notte, all'operatività quotidiana, accogliendo funzioni un tempo demandate alla camera da letto.

EN A single large room houses a walk-in closet and bedroom with walls that are not barriers but glimpses towards the brightness and grandeur of the sleeping space. Rethinking the way of organizing space in the bedroom is the real revolution. Contemporary walk-in closets must respect the rules of space but at the same time open up to the sleeping area, to daily operations, accommodating functions that are sometimes delegated to the bedroom.

FR Un seul grand espace accueille le dressing et la chambre à coucher, avec des murs qui ne sont pas des barrières, mais des ouvertures vers la luminosité et la grandeur de l'espace nuit. Repenser l'organisation de l'espace dans la chambre à coucher est la véritable révolution. Les dressings contemporains doivent respecter les règles de l'espace tout en s'ouvrant sur la chambre, sur l'aspect fonctionnel du quotidien, accueillant des fonctions traditionnellement attribuées à la chambre à coucher.

ES Una sola habitación grande alberga un vestidor y un dormitorio con paredes que no son barreras sino que vislumbran el brillo y la grandeza del espacio para dormir. Repensar la forma de organizar el espacio en el dormitorio es la auténtica revolución. Los vestidores contemporáneos deben respetar las reglas del espacio pero al mismo tiempo abrirse a la zona de noche, a las operaciones diarias, acogiendo funciones que a veces se delegan al dormitorio.









“
PER DIVIDERE,
MA ANCHE
PER UNIRE
*TO DIVIDE,
BUT ALSO
TO UNITE*
”

03.

Pour diviser, mais aussi pour unir . Dividir, pero también unir







Composit ridisegna la classica cassetiera in un'isola accessoriata per migliorare gli spazi del contenimento. Elementi modulari che permettono di creare infinite combinazioni; un volume rivestito dalle numerose finiture disponibili, funzionale alla vita quotidiana con vani porta oggetti, cassetti e seduta per adattarsi ad un essere sempre più versatile.

EN Composit redesigns the classic chest of drawers into an island equipped with accessories to improve the storage spaces. Modular elements that allow you to create infinite combinations; a volume covered in numerous available finishes, functional for everyday life with object storage compartments, drawers and seating to adapt to an increasingly versatile living.

FR Composit redéfinit la classique commode en une île équipée pour améliorer les espaces de rangement. Des éléments modulaires qui permettent de créer d'infinies combinaisons ; un volume revêtu des nombreuses finitions disponibles, fonctionnel au quotidien avec des compartiments de rangement, des tiroirs et un siège, pour s'adapter à un mode de vie de plus en plus polyvalent.

ES Composit rediseña la clásica cómoda en una isla equipada con accesorios para mejorar los espacios de almacenamiento. Elementos modulares que te permiten crear infinitas combinaciones; un volumen revestido con numerosos acabados disponibles, funcional para el día a día con compartimentos portaobjetos, cajones y asientos para adaptarse a un ser cada vez más versátil.



Technical data

Dati Tecnici . Données Techniques . Datos técnicos

Modularità armadi

Wardrobes modularity . Modularité armoires . Modularidad armarios

Modulistica Larghezze . Length modularity . Modularité longueur . Modularidad longitud

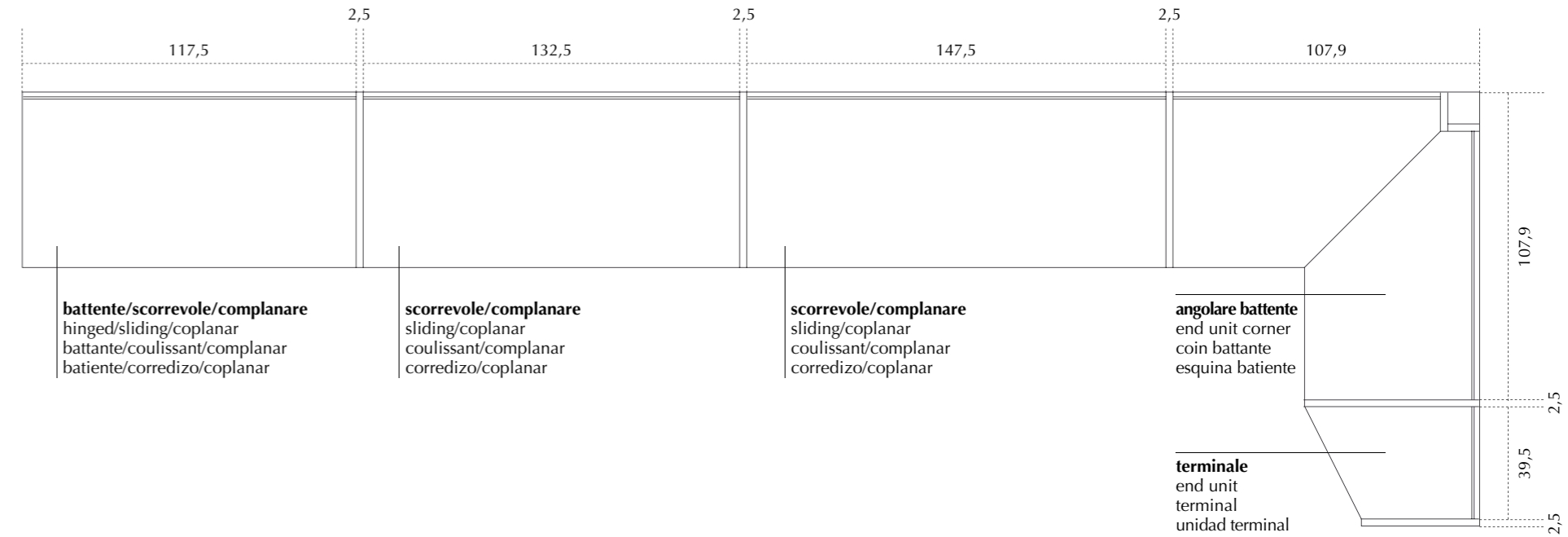
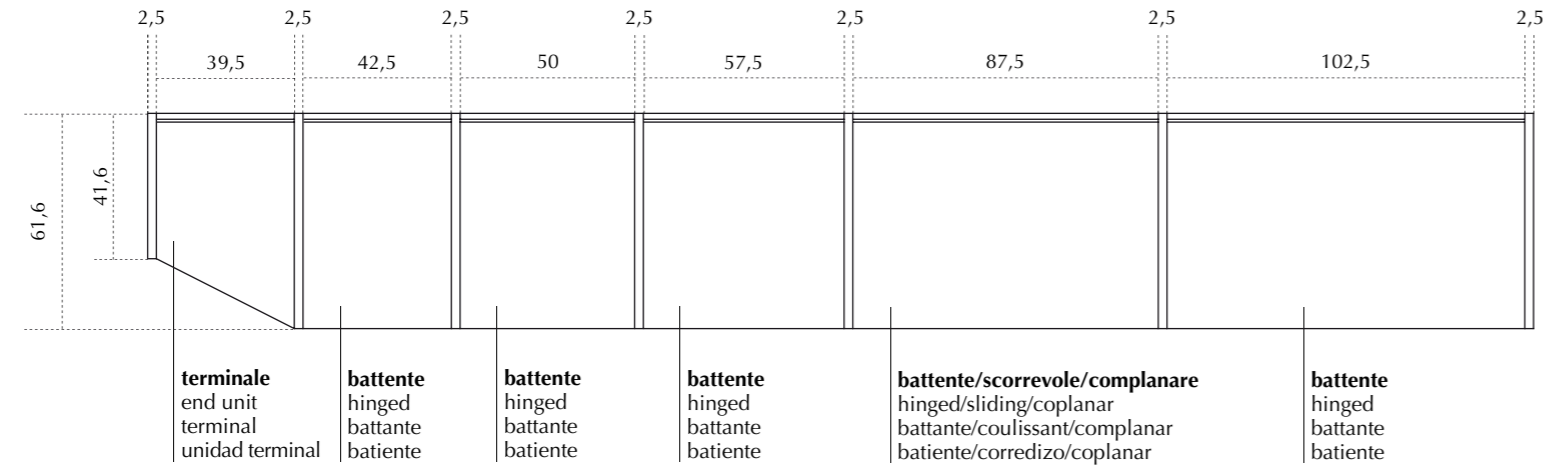

ANTE BATTENTI Hinged doors . Portes battantes . Puertas batientes

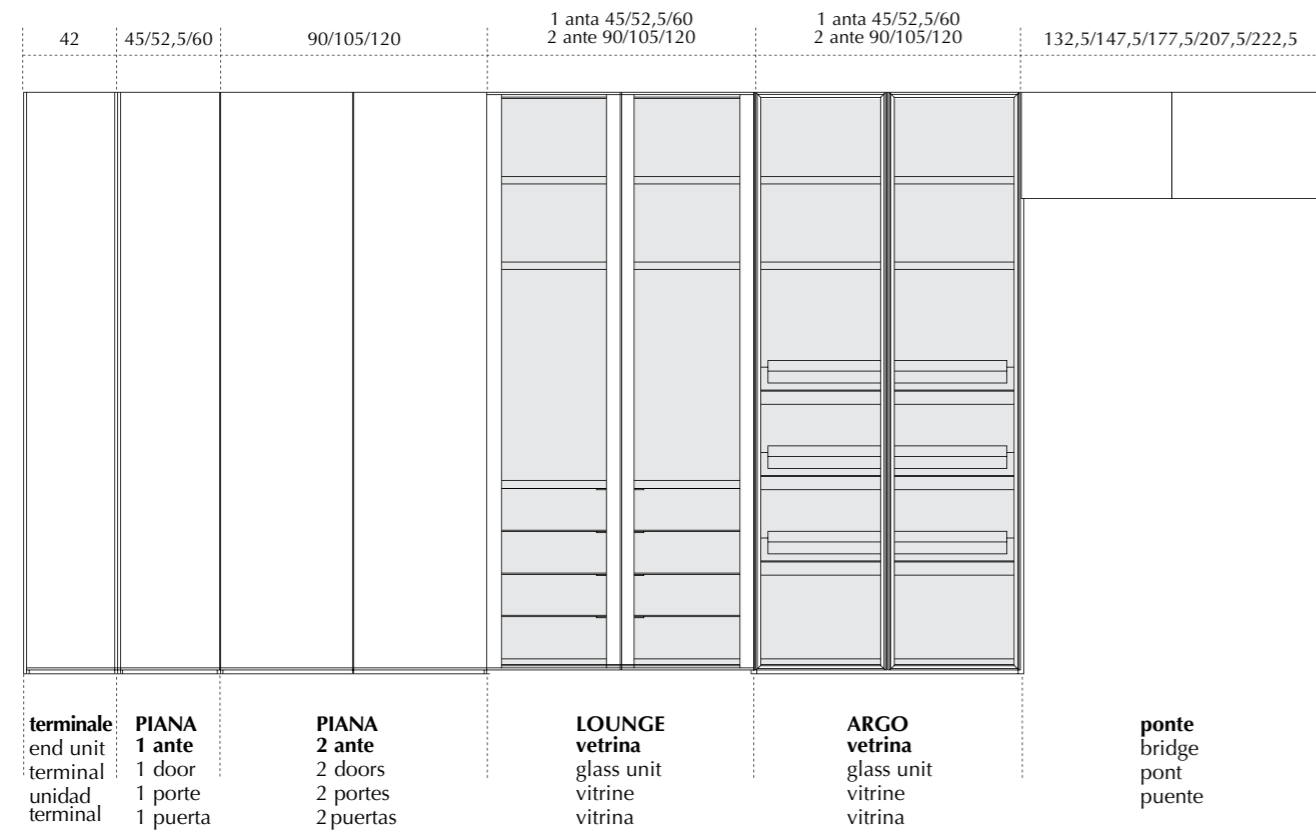

ANTE SCORREVOLI Sliding doors . Portes coulissantes . Puertas corredizas

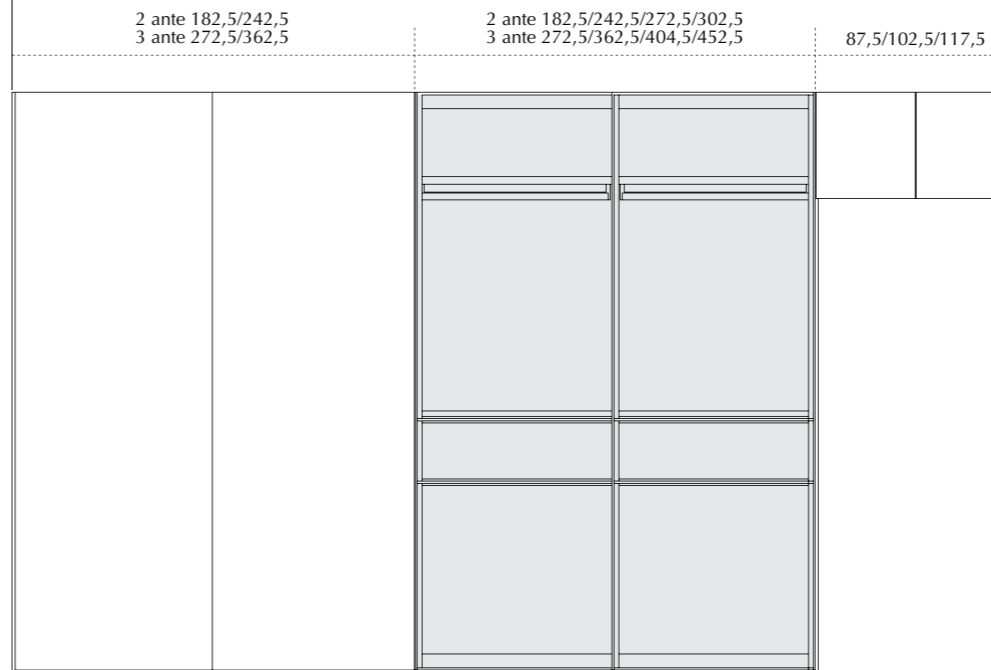

ANTE COMPLANARI Coplanar doors . Portes Complanaires . Puertas coplanares

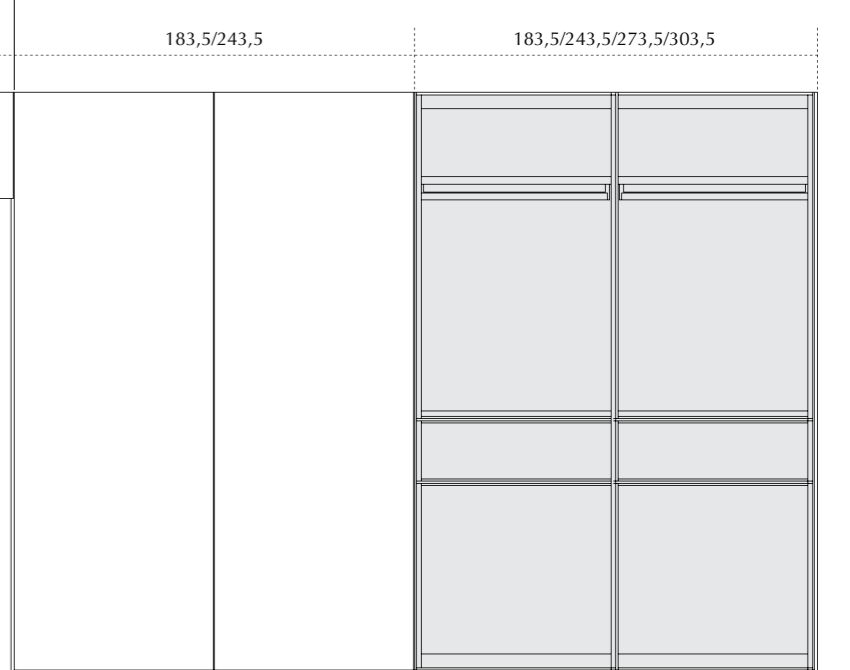

Modularità armadi

Wardrobes modularity . Modularité armoires . Modularidad armarios

Modulistica altezze . Heights modularity . Modularité hauteurs . Modularidad altura

BATTENTE Hinged . Battante . Batiente

SCORREVOLE Sliding . Coulissant . Corredizo

COMPLANARE Coplanar . Complanar . Coplanar

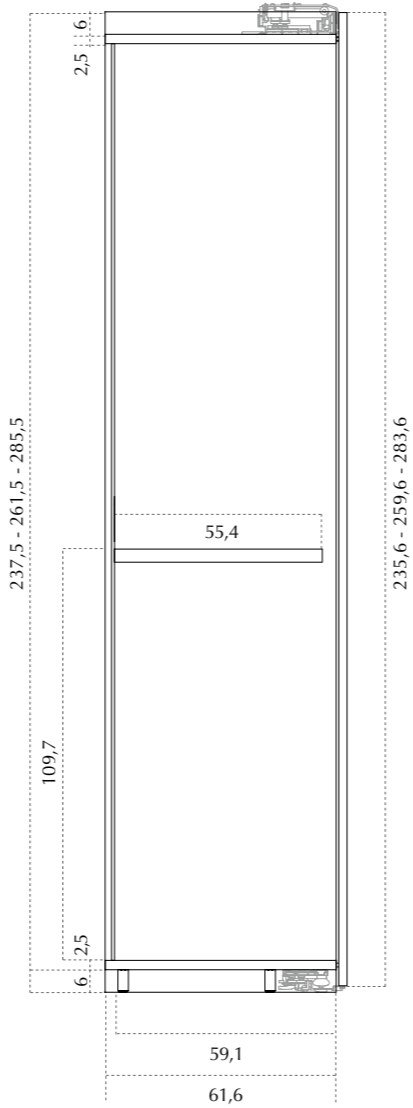
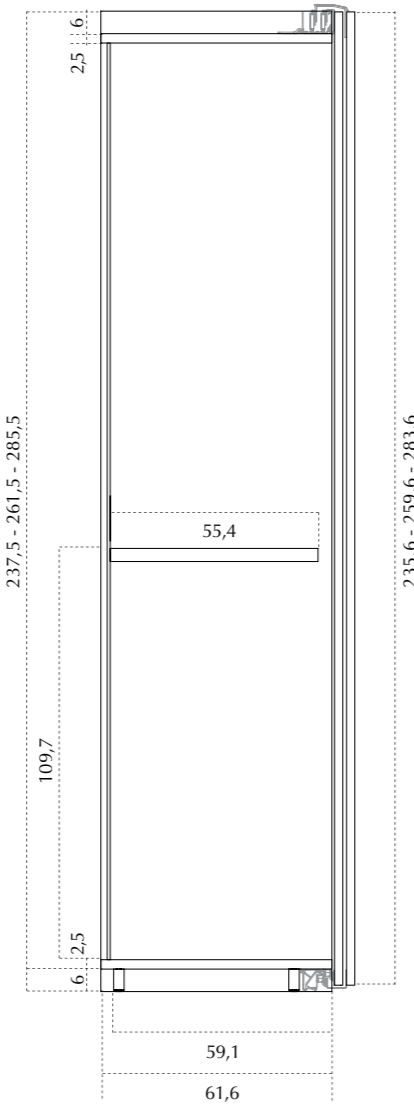
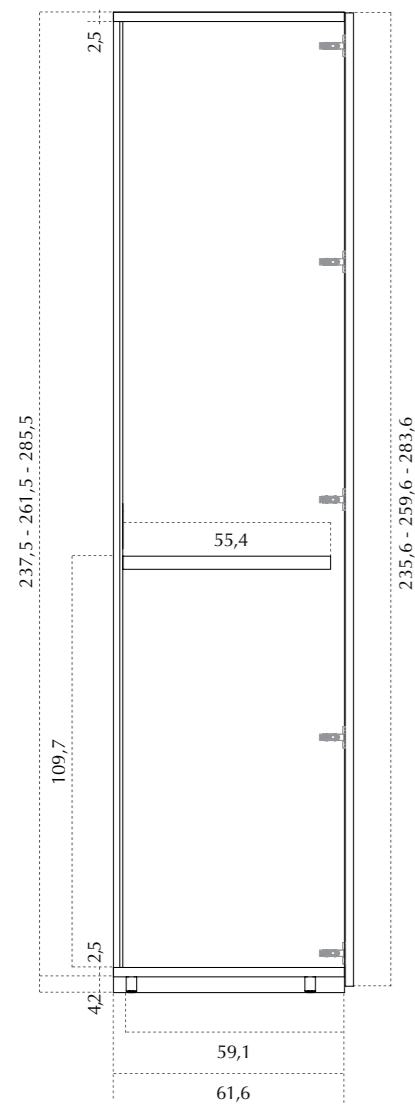

Modulistica profondità . Depths modularity . Modularité profondeurs . Modularidad profundidad

BATTENTE Hinged . Battante . Batiente

PIANA - YOGO - LOUNGE

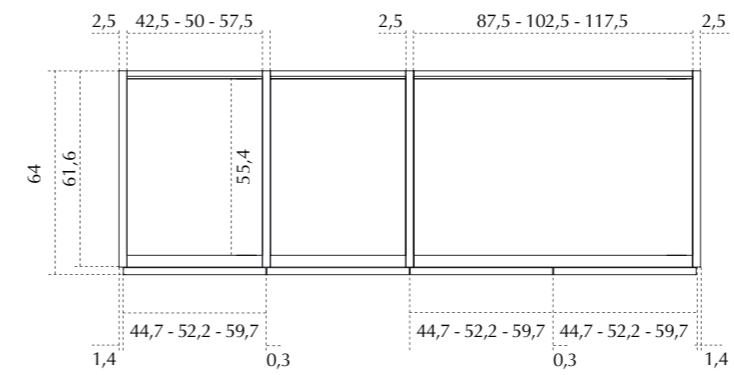

ARGO

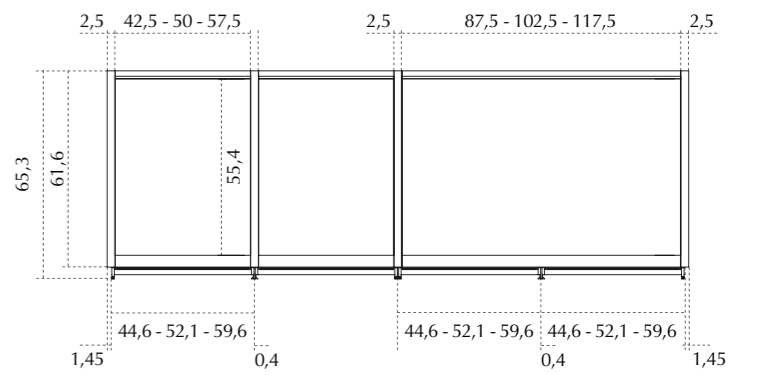

SCORREVOLE Sliding . Coulissant . Corredizo

PIANA

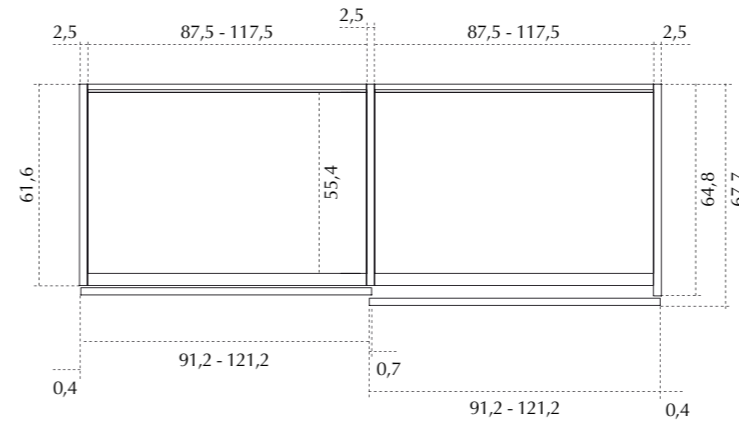

EXTRA

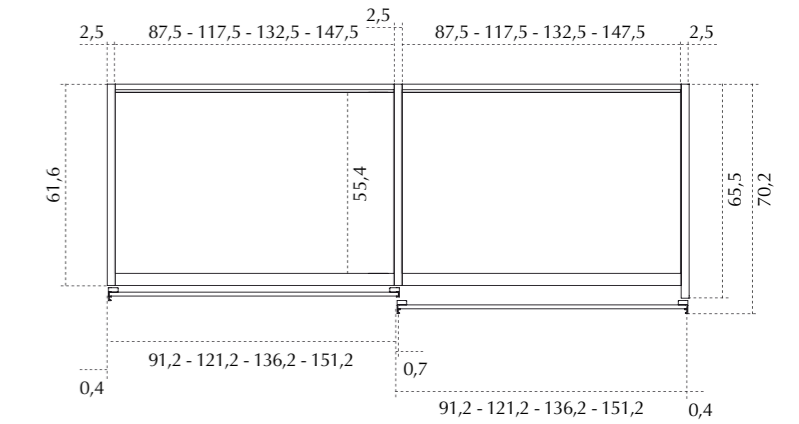

COMPLANARE Coplanar . Complanar . Coplanar

PIANA - YOGO - LOUNGE

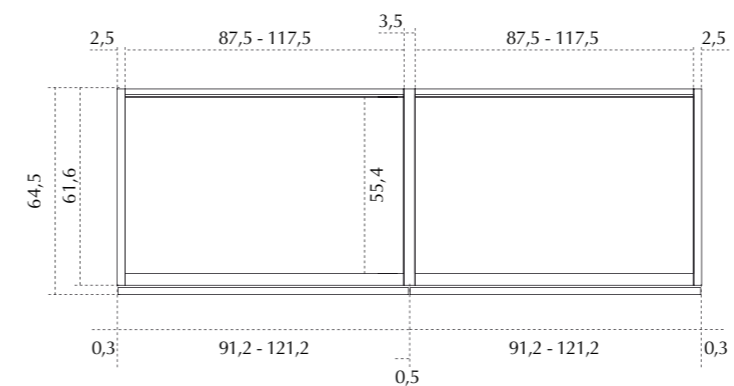

EXTRA

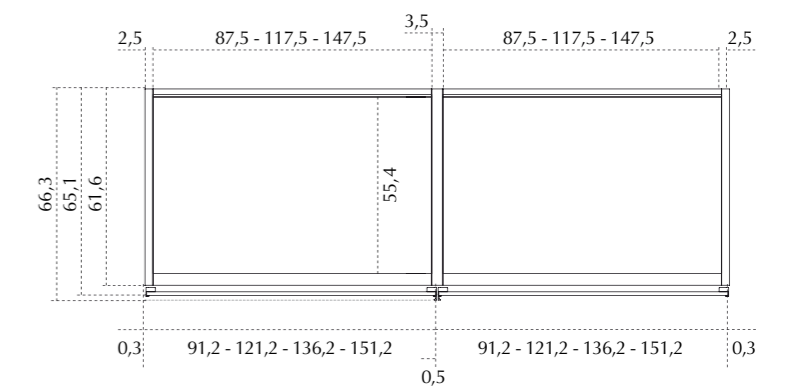

Armadi ante battenti

Hinged doors wardrobes . Armoires portes battantes . Armarios puertas batientes



PIANA



YOGO



LOUNGE



LOUNGE VETRINA



ARGO

Armadi ante scorrevoli

Sliding doors wardrobes . Armoires portes coulissantes . Armarios puertas corredizas

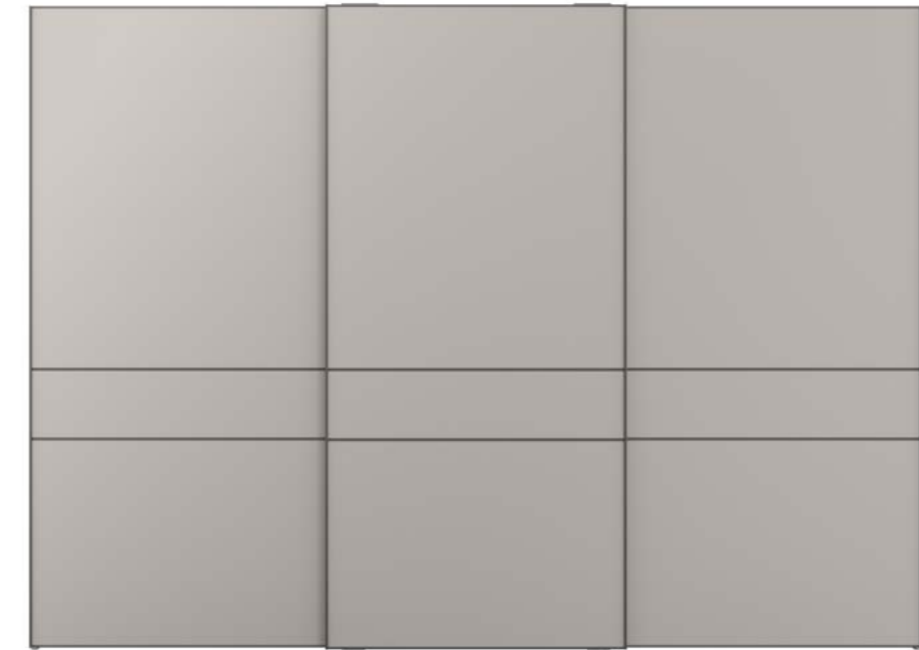

EXTRA



PIANA

Armadi ante complanari

Coplanar doors wardrobes . Armoires portes coplanaires . Armarios puertas coplanares

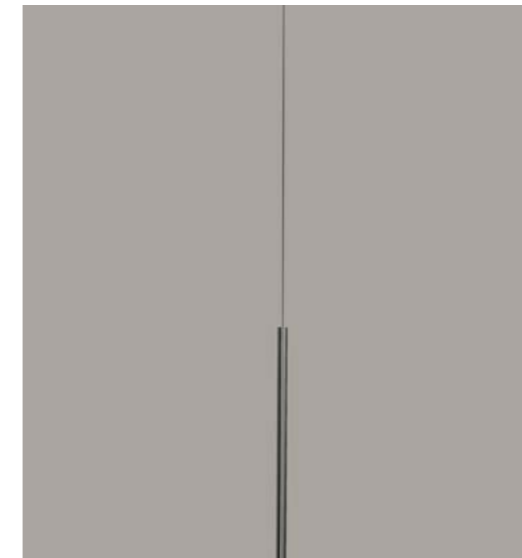

PIANA

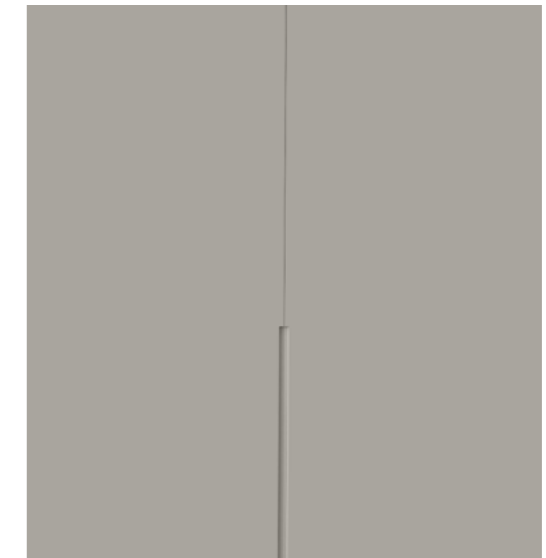

YOGO

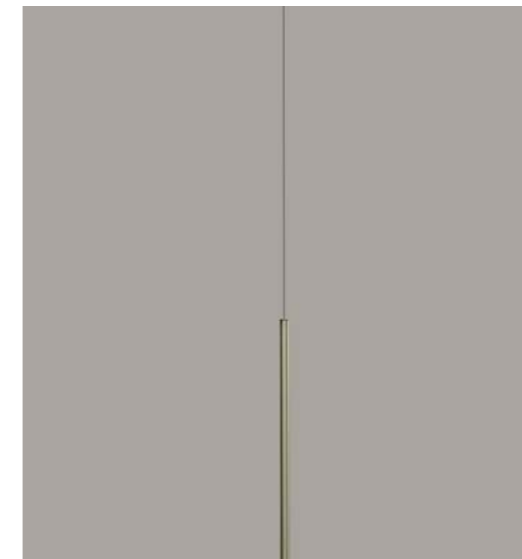

LOUNGE



EXTRA

Tipologia ante

Door types . Type de portes . Tipo de puertas

PIANA

sp. 22 mm

APERTURE Openings . Ouvertures . Aperturas

BATTENTE Hinged . Battante . Batiente

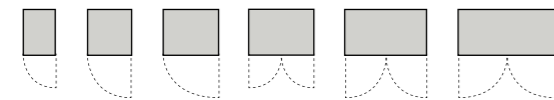

L 45 cm L 52,5 cm L 60 cm L 90 cm L 105 cm L 120 cm



terminale end unit terminal unidad terminal DX/SX angolo corner angles esquina DX/SX L a misura . to measure sur mesure . a medida

H 237,5 / 261,5 / 285,5 cm
H a misura . to measure . sur mesure . a medida

SCORREVOLE Sliding . Coulissant . Corredizo



L 90 cm L 120 cm L a misura . to measure sur mesure . a medida

H 237,5 / 261,5 / 285,5 cm
H a misura . to measure . sur mesure . a medida

COMPLANARE Coplanar . Complanar . Coplanar



L 90 cm L 120 cm L a misura . to measure sur mesure . a medida

H 237,5 / 261,5 cm
H 285,5 solo L 90 / only L 90 / solo L 90 / solo L 90
H a misura . to measure . sur mesure . a medida

MANIGLIE Handles . Poignées . Manejas

BLADE / MONO / WZ4 / WZ7 / WY1
WG2 / WZ2

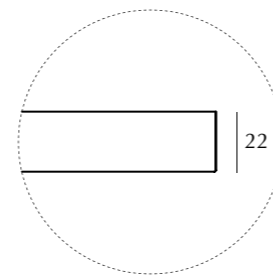

YOGO

sp. 22 mm

APERTURE Openings . Ouvertures . Aperturas

BATTENTE Hinged . Battante . Batiente

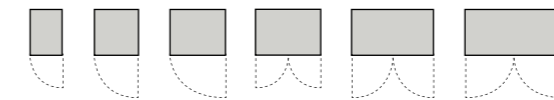

L 45 cm L 52,5 cm L 60 cm L 90 cm L 105 cm L 120 cm



terminale end unit terminal unidad terminal DX/SX angolo corner angles esquina DX/SX L a misura . to measure sur mesure . a medida

H 237,5 / 261,5 / 285,5 cm
H a misura . to measure . sur mesure . a medida

COMPLANARE Coplanar . Complanar . Coplanar



L 90 cm L 120 cm L a misura . to measure sur mesure . a medida

H 237,5 / 261,5 cm
H 285,5 solo L 90 / only L 90 / solo L 90 / solo L 90
H a misura . to measure . sur mesure . a medida

MANIGLIE Handles . Poignées . Manejas

YOGO

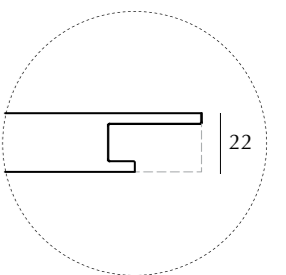

Tipologia ante

Door types . Type de portes . Tipo de puertas

LOUNGE

sp. 22 mm

APERTURE Openings . Ouvertures . Aperturas

BATTENTE Hinged . Battante . Batiente

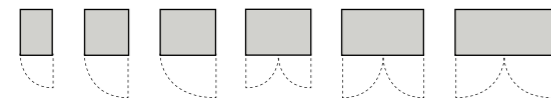

L 45 cm L 52,5 cm L 60 cm L 90 cm L 105 cm L 120 cm

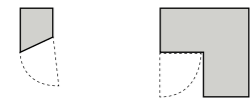

terminale
end unit
terminal
unidad terminal
DX/SX

angolo
corner
angles
esquina
DX/SX

L a misura . to measure
sur mesure . a medida

H 237,5 / 261,5 / 285,5 cm
H a misura . to measure . sur mesure . a medida

COMPLANARE Coplanar . Coplanar . Coplanar



L 90 cm L 120 cm L a misura . to measure
sur mesure . a medida

H 237,5 / 261,5 cm
H 285,5 solo L 90 / only L 90 / solo L 90 / solo L 90
H a misura . to measure . sur mesure . a medida

MANIGLIE Handles . Poignées . Manejas

LOUNGE

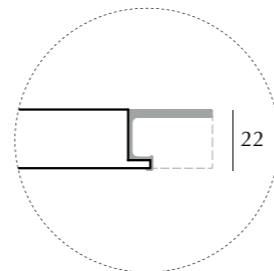

EXTRA

sp. 40 mm

APERTURE Openings . Ouvertures . Aperturas

SCORREVOLE Sliding . Coulissant . Corredizo



L 90 cm L 120 cm



L 135 cm L 150 cm L a misura . to measure
sur mesure . a medida

H 237,5 / 261,5 / 285,5 cm
H a misura . to measure . sur mesure . a medida

COMPLANARE Coplanar . Coplanar . Coplanar



L 90 cm L 120 cm



L 135 cm L 150 cm L a misura . to measure
sur mesure . a medida

H 237,5 / 261,5 / 285,5 cm
H a misura . to measure . sur mesure . a medida

TELAIO Metalgrey . Metalgrey Frame
Cadre Metalgrey . Marco Metalgrey

MANIGLIE Handles . Poignées . Manejas

Integrata nel telaio Integrated in the frame
Intégrée dans le cadre . Integrada en el marco

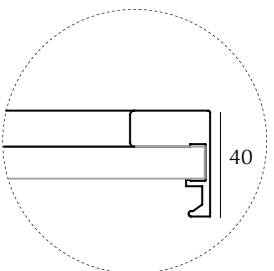
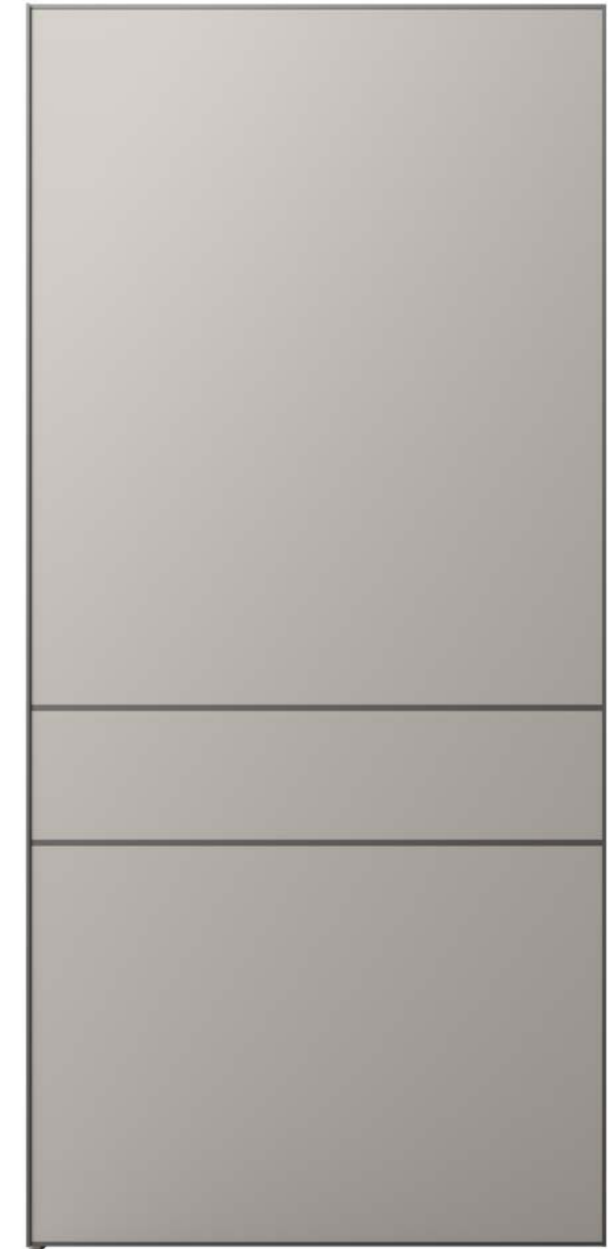

Tipologia ante

Door types . Type de portes . Tipo de puertas

LOUNGE VETRINA

sp. 22 mm

APERTURE Openings . Ouvertures . Aperturas

BATTENTE Hinged . Battante . Batiente

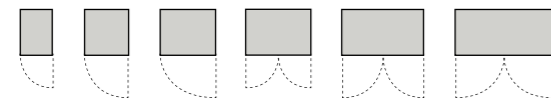

L 45 cm L 52,5 cm L 60 cm L 90 cm L 105 cm L 120 cm

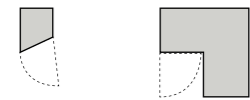

terminale
end unit
terminal
unidad terminal
DX/SX

angolo
corner
angles
esquina
DX/SX

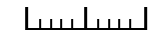

L a misura . to measure
sur mesure . a medida

H 237,5 / 261,5 / 285,5 cm
H a misura . to measure . sur mesure . a medida

TELAIO Anodizzato Titanio/Nero
Anodized frame Titanium/Black . Cadre anodisé titane/noir
Marco anodizado Titanio/Negro

MANIGLIE Handles . Poignées . Manejas

Integrata nel telaio Integrated in the frame
Intégrée dans le cadre . Integrada en el marco

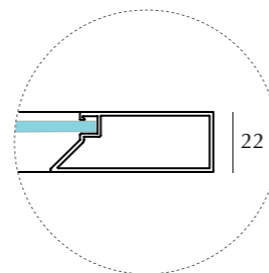

ARGO VETRINA

sp. 35 mm

APERTURE Openings . Ouvertures . Aperturas

BATTENTE Hinged . Battante . Batiente

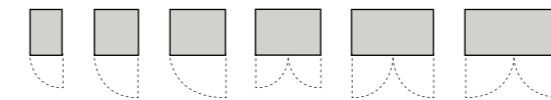

L 45 cm L 52,5 cm L 60 cm L 90 cm L 105 cm L 120 cm



terminale
end unit
terminal
unidad terminal
DX/SX

angolo
corner
angles
esquina
DX/SX

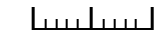

L a misura . to measure
sur mesure . a medida

H 237,5 / 261,5 / 285,5 cm
H a misura . to measure . sur mesure . a medida

TELAIO Metalgrey . Metalgrey Frame
Cadre Metalgrey . Marco Metalgrey

MANIGLIE Handles . Poignées . Manejas

Integrata nel telaio Integrated in the frame
Intégrée dans le cadre . Integrada en el marco

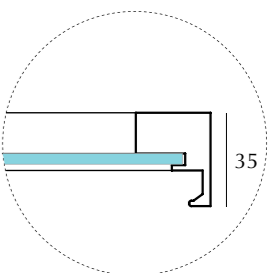

Elementi speciali: angolare battente

Special elements: hinged . Éléments spéciaux: angulaire battant . Elementos especiales: esquina batiente

DIMENSIONI

Dimensions . Dimensions . Medidas

L 110,4 x 107,9 cm

P 61,6 cm

H 237,5 / 261,5 / 285,5 cm

TIPOLOGIE ANTA

Doors types . Typologies des portes

Tipo de puertas

PIANA , YOGO, LOUNGE

LOUNGE VETRINA, ARGO

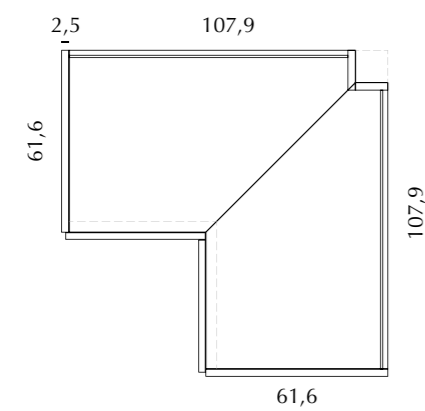

Elementi speciali: terminale battente

Special elements: hinged end . Éléments spéciaux: terminal battant . Elementos especiales: terminal batiente

DIMENSIONI

Dimensions . Dimensions . Medidas

L 42 cm

P 61,6 cm

H 237,5 / 261,5 / 285,5 cm

TIPOLOGIE ANTA

Doors types . Typologies des portes

Tipo de puertas

PIANA , YOGO, LOUNGE

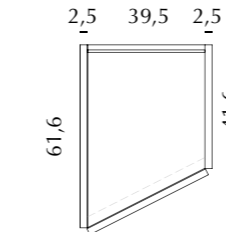

Elementi speciali: ponte

Special element: bridge . Éléments spéciaux: pont . Elementos especiales: puente

DIMENSIONI

Dimensions . Dimensions . Medidas
L 132,5 / 147,5 / 177,5 / 207,5 / 222,5 cm
P 61,6 cm
H 48 / 72 / 96 / 120 cm

TIPOLOGIE ANTA

Doors types . Typologies des portes
Tipo de puertas
PIANA , YOGO, LOUNGE



Finiture ante

Door finishes . Finitions des portes . Acabados puertas

PIANA



YOGO



LOUNGE



EXTRA



	B	S	C	B	S	C	B	S	C	B	S	C
LAMINATI Laminates . Laminées . Laminados												
Laminato b.p. Supermatt L.p. laminate Supermatt lacquered Laminè b.p. laqué Supermatt . Laminado b.p. laccado Supermatt	●	●	●				●		●		●	●
Laminato b.p. L.p. laminate . Laminé b.p. . Laminado b.p.	●	●	●				●		●			
Fenix Fenix . Fenix . Fenix	●	●	●				●		●			
Laminato Rigato b.p. Ribbed l.p. laminate . Laminé b.p. nervurée Laminado b.p. estriado	●	●	●				●		●			
LACCATO OPACO Mat lacquered . Laqué mat . Lacado mat												
Laccato liscio Plain lacquered . Laqué lisse . Lacado liso	●	●	●	●		●	●		●		●	●
Laccato Textured Textured Laquered . Laqué Texturé . Lacado Texturizado	●	●	●				●		●			
Laccato Metallo eff. Graffiato Scratched metal lacquered Laqué métallisé effet rayé . Lacado metalizado rayado	●	●	●	●		●	●		●		●	●
Laccato speciale Special lacquered . Laqué spécial . Lacado especial	●	●	●	●		●	●		●		●	●
LACCATO LUCIDO Glossy lacquered . Laqué brillant . Lacado brillante	●	●	●				●		●		●	●
IMPIALLACCIATI Wood veneered . Bois plaqué . Madera enchapada	●	●	●				●		●		●	●
VETRI Glass . Verre . Cristal											●	●

B battente . hinged . battante . batiente

S scorrevole . sliding . coulissant . corredizo

C complanare . coplanar . complanar . coplanar

Gamma completa delle finiture p.96 . Full range of finishes p. 96
Gamme complete des finitions p.96 . Gama completa acabados p.96

Finiture ante

Door finishes . Finitions des portes . Acabados puertas

VETRINA LOUNGE



B

VETRINA ARGO



B

TELAI IN ALLUMINIO

Aluminium frame . Cadre en aluminium . Marco aluminio

Titanio	●	
Nero	●	
Metalgrey		●

VETRI Glass . Verre . Cristal

V1 Vetro Bronzo Reflecting Mirror-effect bronze Bronze effet miroir . Bronze efecto espejo	●	●
V2 Vetro Stopsol Bronzo Stopsol bronze Bronze Stopsol . Bronze Stopsol	●	●
V3 Vetro Bronzo Bronze . Bronze . Bronze	●	●
V4 Vetro Trasparente Transparent . Transparent . Transparente	●	●
V5 Vetro Fumè Grigio Smoke grey . Gris fumé . Ahumado	●	●
V7 Vetro Satinato Laccato Satin lacquered Laqué satiné . Lacado satinado	●	●
V8 Vetro Lucido Laccato Glass lacquered laqué brillant . lacado brillante	●	●
SP1 Specchio Mirror . miroir . espejo	●	●
SP2 Specchio Bronzo Bronze mirror . miroir bronze . espejo bronze	●	●
SP3 Specchio Fumè Smoke mirror . miroir fumé . espejo ahumado	●	●

B battente . hinged . battante . batiente

Gamma completa delle finiture p. 96 . Full range of finishes p. 96
Gamme complete des finitions p.96 . Gama completa acabados p.96

Maniglie

Handles . Poignées . Manejas



YOYO
H 27 cm

Finitura come anta
Finish as doors
Finition comme portes
Acabado como puertas

Ante Battente / Complanare
Hinged / Coplanar doors
Portes battantes / Complanar
Puertas batientes / Coplanar



YOYO
H 112 / 235,6 / 259,6 / 283,6 cm

Finitura come anta
Finish as doors
Finition comme portes
Acabado como puertas

Ante Battente / Complanare
Hinged / Coplanar doors
Portes battantes / Complanar
Puertas batientes / Coplanar



LOUNGE
H 112 / 235,6 / 259,6 cm

Finitura Titanio / Laccato opaco-lucido
Titanium / Mat-Glossy lacquered finish
Finition Titane / Laqué matt-brillant
Acabado Titanio / Lacado mate-brillo

Ante Battente / Complanare
Hinged / Coplanar doors
Portes battantes / Complanar
Puertas batientes / Coplanar



LOUNGE
H 27 cm

Finitura Titanio / Laccato opaco-lucido
Titanium / Mat-Glossy lacquered finish
Finition Titane / Laqué matt-brillant
Acabado Titanio / Lacado mate-brillo

Ante Battente / Complanare
Hinged / Coplanar doors
Portes battantes / Complanar
Puertas batientes / Coplanar



WZ4
H 16 cm

Finitura Laccato opaco
Matt lacquer finish
Finition Laqué matt
Acabado Lacado mate

Ante Battente
Hinged doors
Portes battantes
Puertas batientes



WZ7
H 23,6 / 58,8 / 84,4 cm

Finitura Nero
Black finish
Finition noir
Acabado negro

Ante Battente / Scorrevole
Hinged / Sliding doors
Portes battantes / Coulissant
Puertas batientes / Corredizo



WY1
H 20,7 cm

Finitura Laccato opaco-lucido
Matt-glossy lacquer finish
Finition Laqué matt-brillant
Acabado Lacado mate-brillo

Ante Battente / Scorrevole / Complanare
Hinged / sliding / Coplanar doors
Portes battantes / Coulissant / Complanar
Puertas batientes / Corredizo / Coplanar



WG2
H 3 / Ø 1,2 cm

Finitura Verniciatura nero
Black paint finish
Finition Laqué matt-brillant
Acabado Lacado mate-brillo

Ante Battente / Cassettiere
Hinged doors / Chests of drawers
Portes battantes / Commode
Puertas batientes / Cómoda



BLADE
H 15 cm

Finitura Metalgrey
Metalgrey finish
Finition Metalgrey
Acabado Metalgrey

Ante Battente / Cassettiere
Hinged doors / Chests of drawers
Portes battantes / Commode
Puertas batientes / Cómoda



MONO
H 112 cm

Finitura Metalgrey
Metalgrey finish
Finition Metalgrey
Acabado Metalgrey

Ante Battente
Hinged doors
Portes battantes
Puertas batientes



MONO
H 20 cm

Finitura Metalgrey
Metalgrey finish
Finition Metalgrey
Acabado Metalgrey

Ante Battente / Cassettiere
Hinged doors / Chests of drawers
Portes battantes / Commode
Puertas batientes / Cómoda



WZ2
H 25 cm

Finitura Titanio / Nero / Alluminio
Titanium / Black / Alluminium finish
Titanium / Noir / Aluminium finish
Acabado Titanio / Negro / Aluminio

Ante Battente
Hinged doors
Portes battantes
Puertas batientes

Modularità cabine armadio

Walk-in closets modularity . Modularité des cabines de dressing . Modularidad vestidor

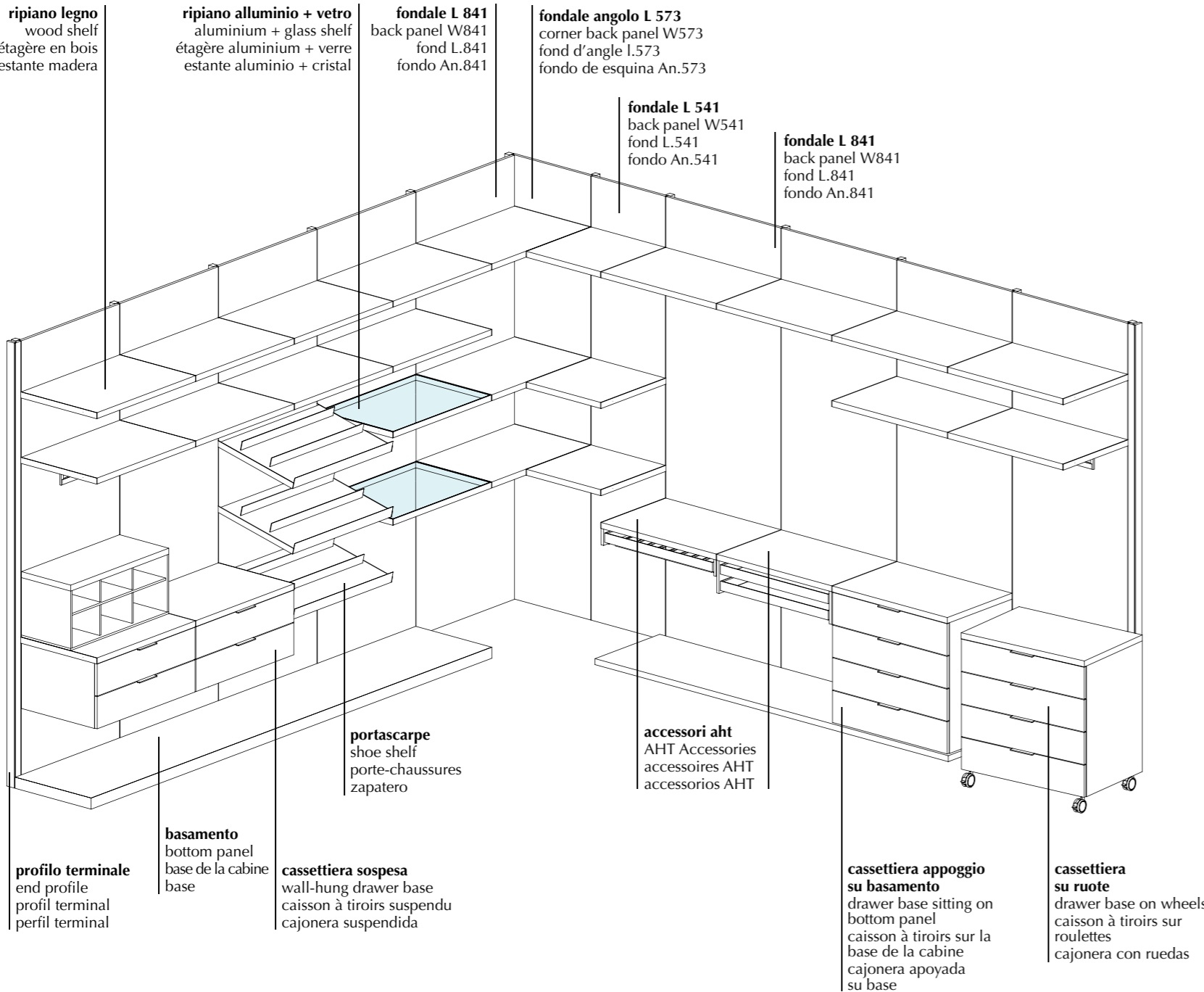

Modulistica larghezza . Widths modularity . Modularité largeur . Modularidad anchos

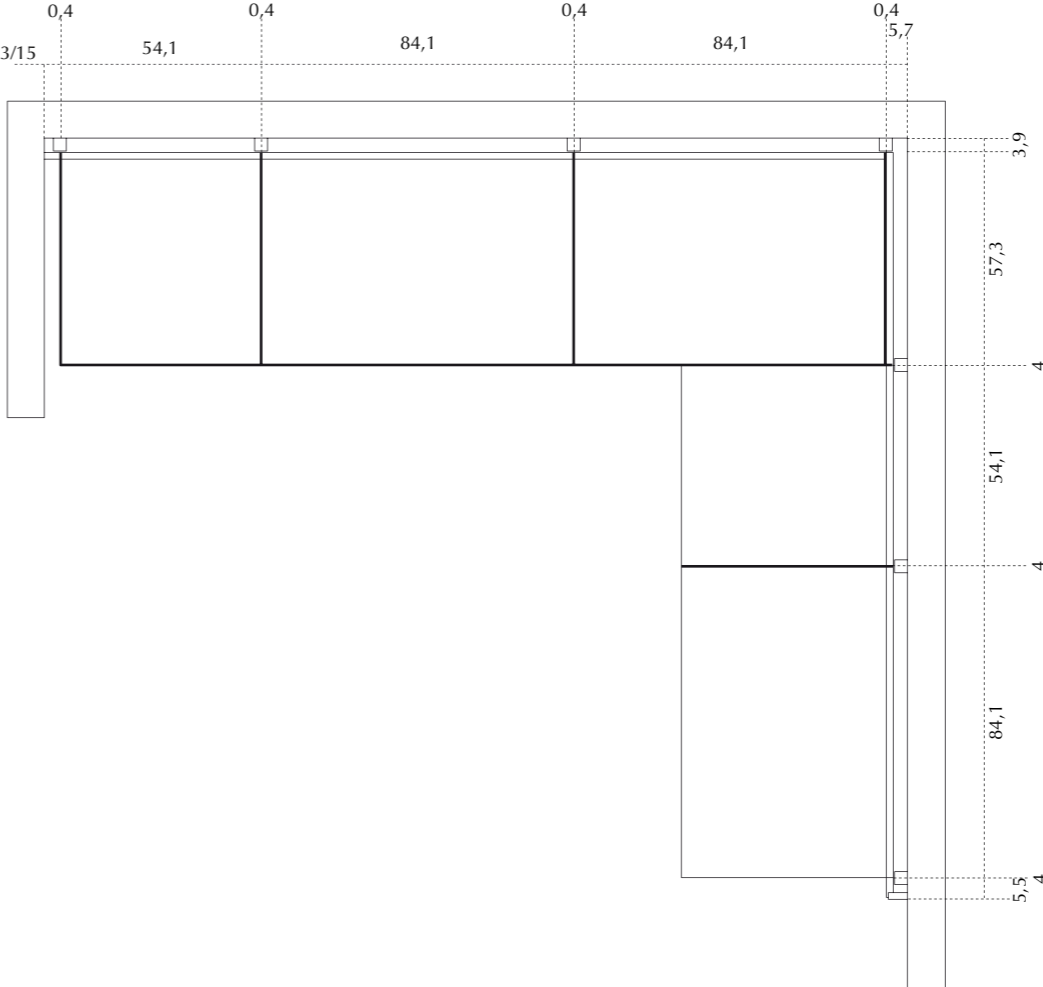

DETTAGLIO CREMAGLIERA . Upright detail . Détail du montant . Detalle del perchero

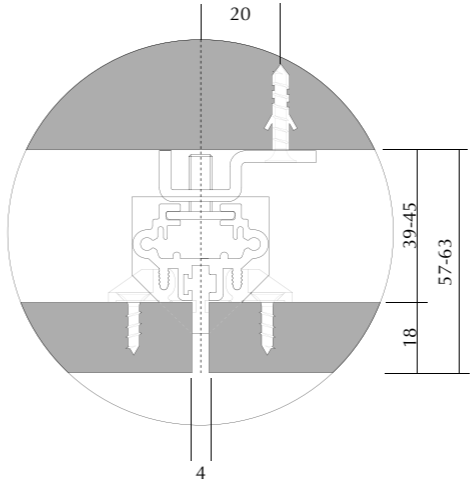

Modularità cabine armadio

Walk-in closets modularity . Modularité des cabines de dressing . Modularidad vestidor

Modulistica altezze e profondità . Heights and depths modularities . Modularité hauteurs et profondeurs
Modularidad alturas y profundidades

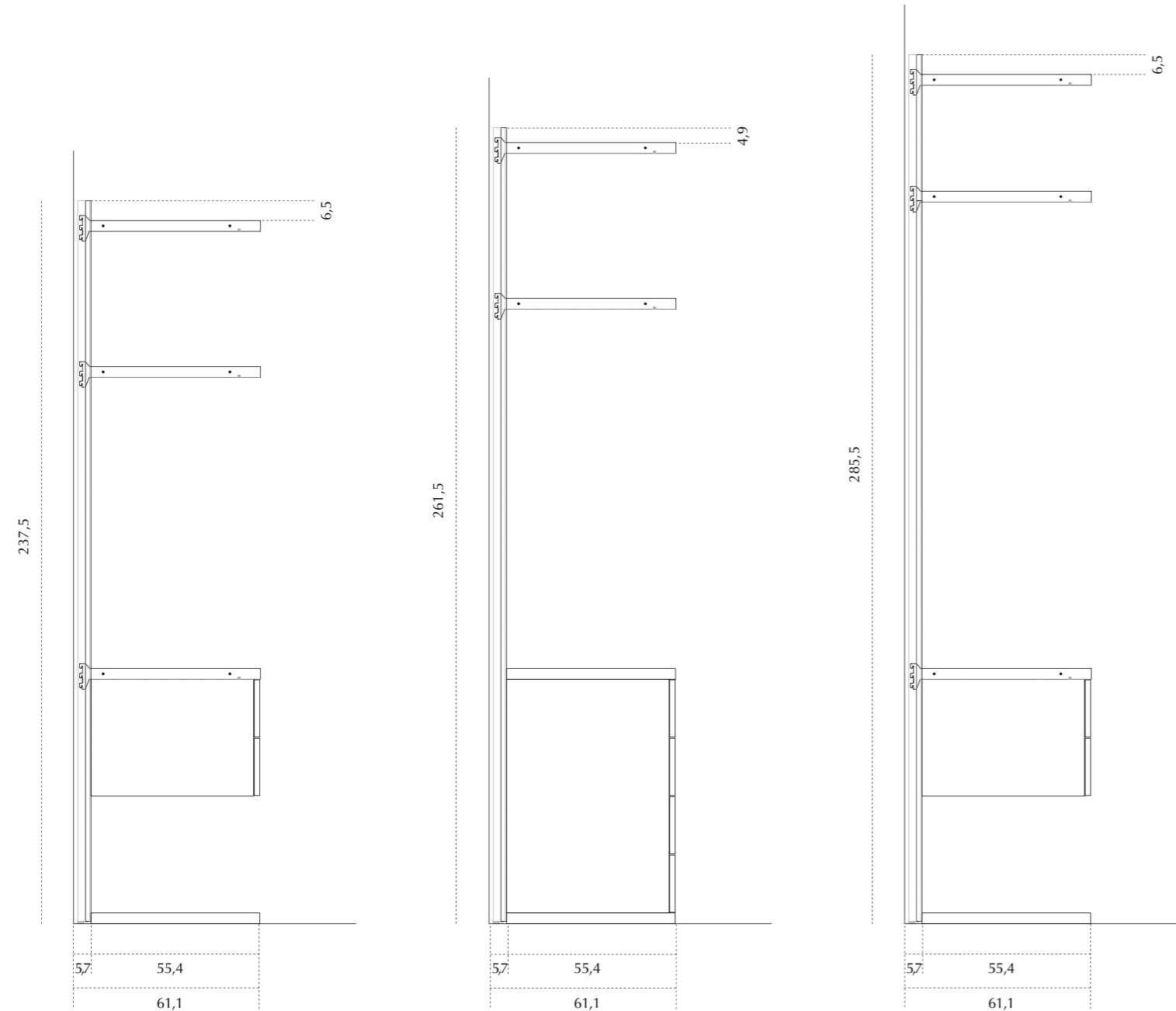

Tutti i ripiani e le cassettiere sospese possono essere spostati con passo 3,2 cm . All shelves and wall-hung drawer bases can be moved every 3,2cm
Toutes les étagères et tous les tiroirs suspendus peuvent être déplacés par intervalles de 3,2 cm . Todos los estantes y cajones colgantes se pueden mover en pasos de 3,2 cm.

Finiture cabine armadio

Walk-in closets finishes . Finitions des cabines de dressing . Acabados vestidor

	Pannello Fondale Back panel Panneau du fond Fondo	Pannello Angolo Corner back panel Panneau d'angle Panel de esquina	Profilo Terminale End profile Profil terminal Perfil terminal	Ripiani e basamento Shelves and bottom panel Étagères et base Estantes y bases	Cassettiere Drawer bases Caisson à tiroir Cajoneras
LAMINATI Laminates . Laminées . Laminados					
Laminato struttura Structure laminate Laminé de structure . Laminado esctructura	●	●	●	●	●
Laminato b.p l.p Laminate Laminé b.p . laminado b.p	●	●	●		
LACCATO OPACO Mat lacquered . Laqué mat . Lacado mat					
Laccato opaco liscio Mat plain lacquered Laqué mat lisse . Lacado liso mate	●	●	●	●	●
VETRI Glass . Verre . Cristal					
SP1 Specchio Mirror . Miroir . Espejo	●	●			
SP2 Specchio Bronzo Bronze mirror miroir bronze . espejo bronze	●	●			
SP3 Specchio Fumè Smoke mirror Miroir fumé . Espejo ahumado	●	●			

Gamma completa delle finiture p. 96 . Full range of finishes p. 96
Gamme complete des finitions p.96 . Gama completa acabados p.96

Attrezzatura interna armadi/cabine armadio

Wardrobes/walk-in closets interior equipments . Équipement interne des armoires/cabines de dressing
Equipamiento interior para armarios/vestidores

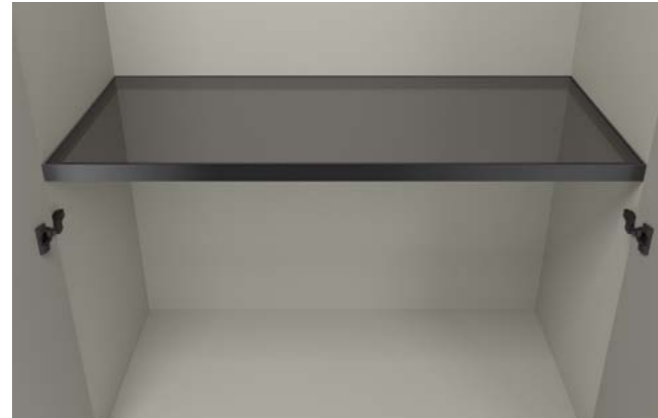

Ripiano vetro fisso
Fixed glass shelf . Étagère en verre fixe . Estante fijo cristal



Vassoio estraibile ripiano nobilitato
Pull-out laminate shelf . Plateau coulissant en mélamine
Bandeja extraíble con estante de melamina



Ripiano legno estraibile
Pull-out wood shelf . Tablette en bois extractible
Estante de madera extraíble



Vassoio estraibile ripiano vetro
Pull-out glass shelf . Plateau coulissant en verre
Bandeja extraíble con estante de cristal



Portascarpe legno estraibile
Pull-out shoe shelf . Porte-chaussures amovible
Estante zapatero extraíble



Raster divisorio
Raster divider . Raster Diviseur . Raster divisor



Servetto
Servetto . Servetto . Servetto



Asta appendiabiti
Hanging bar . Barre de penderie . Barra colgador



Portascarpe
Shoe shelf . Zapatero . Porte-chaussures



Griglia portapantaloni
Trousers rack . Grille porte-pantalons . Perchero para pantalones



Sacca portabiancheria singola
Single laundry bag . Sac porte-ligne simple
Bolsa de lavandería individual



Sacca portabiancheria doppia
Double laundry bag . Sac porte-ligne double . Bolsa de lavandería doble

Finiture interne

Interior Finishes . Finitions intérieures . Acabados internos

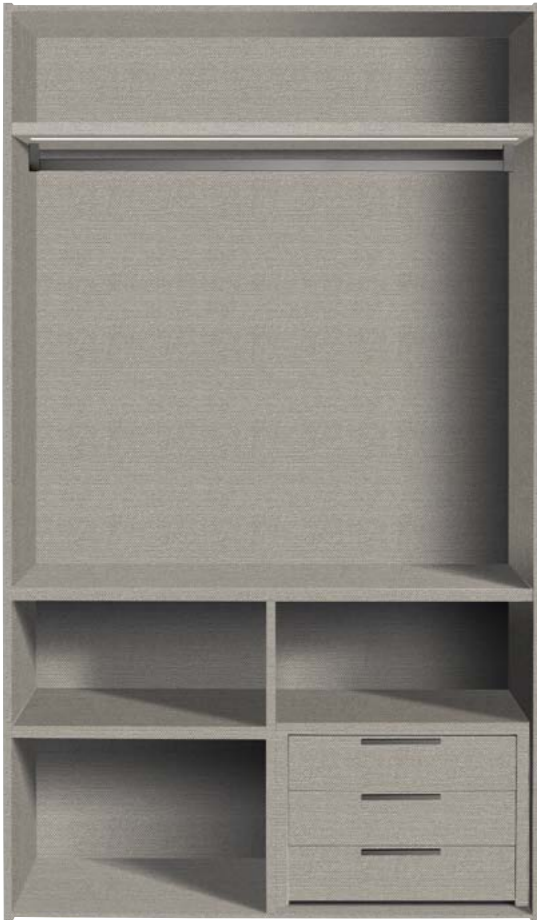

ALPACA - AA



CANAPA PRIMO FIORE - PP



SABLÈ - RR



PORO NOCE - CC

Finiture ante

Door finishes . Finitions des portes . Acabados puertas

IMPIALLACCIATI / wood veneered / bois plaqué / madera enchapada

legno impiallacciato / wood veneered / bois plaqué / madera enchapada



LK
eucalipto
eucalyptus
eucalyptus
eucalipto



LL
legno antico
antique wood
bois antique
madera antigua



LH
noce americano
american walnut
noyer américain
nogal americano



*** LM**
olmo
elm
orme
olmo



LR
larice verticale bianco
larch veneered white
méleze blanc vertical
alerce blanco vertical

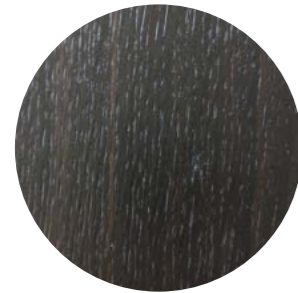

LP
rovere termotrattato
heat-treated oak
chêne thermo-traité
roble tratado térmicamente



*** LS**
eucalipto silver
silver eucalyptus
eucalyptus argent
eucalipto silver

legno impiallacciato rovere tinto vena orizzontale / oak veneered stained with horizontal grains / chêne plaqué veines horizontales
roble enchapado vetas horizontales



LA R01
rovere naturale
natural oak
chêne naturel
roble natural



LA R02
rovere sbiancato
bleached oak
chêne blanchi
roble blanqueado



LA R03
tinto bianco poro scuro
white stain oak
teinté blanc pore foncé
teñido blanco poro oscuro



LA R04
rovere grigio caldo
warm grey stain oak
chêne gris chaud
roble gris caliente



LA R05
tinto grigio chiaro poro scuro
light grey stain oak
teinté gris clair pore foncé
teñido gris claro poro oscuro



LA R06
tinto grigio medio poro scuro
grey stain oak
teinté gris moyen pore foncé
teñido gris medio poro oscuro



LA R07
tinto grigio scuro
dark grey painted
teinté gris foncé
teñido gris oscuro



LA R08
tinto noce
walnut stain oak
teinté noyer
teñido nogal



LA R09
tinto tabacco
tobacco stain oak
teinté tabac
teñido tabaco



LA R10
tinto wengé
wengé stain oak
teinté wengue
teñido wengue

legno impiallacciato rovere laccato poro aperto vena orizzontale / oak veneered open pore lacquered with horizontal grains
chêne plaqué pore ouvert veines horizontales / roble enchapado lacado poro abierto vetas horizontales

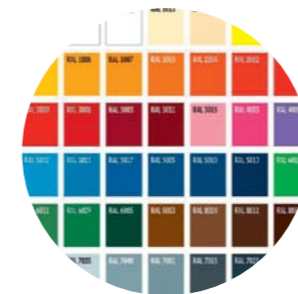

LB A01/A41
laccato opaco poro aperto
open pore mat lacquered
laqué mat pore ouvert
lacado mate poro abierto



LB A00
laccato Ral poro aperto
open pore lacquered Ral
laqué Ral pore ouvert
lacado Ral poro abierto



LB A99
laccato al campione poro aperto
open pore lacquered by sample
laqué pore ouvert à l'échantillon
lacado poro abierto sobre muestra

*Fascia prezzo differente dagli altri legni Different price range from other woods . Gamme de prix différente de celle des autres bois . Rango de precios diferente al de otras maderas.

Finiture ante

Door finishes . Finitions des portes . Acabados puertas

IMPIALLACCIATI / wood veneered / bois plaqué / madera enchapada

legno impiallacciato rovere tinto fiammato vena verticale / oak veneered stained with flamed vertical grains / plaqué veines verticales
roble enchapado vetas verticales



LC R01
rovere naturale
natural oak
chêne naturel
roble natural



LC R02
rovere sbiancato
bleached oak
chêne blanchi
roble blanqueado



LC R03
tinto bianco poro scuro
white stain oak
teinté blanc pore foncé
teñido blanco poro oscuro



LC R04
rovere grigio caldo
warm grey stain oak
chêne gris chaud
roble gris caliente



LC R05
tinto grigio chiaro poro scuro
light grey stain oak
teinté gris clair pore foncé
teñido gris poro oscuro



LC R06
tinto grigio medio poro scuro
grey stain oak
teinté gris moyen pore foncé
teñido gris medio poro oscuro



LC R07
tinto grigio scuro
dark grey painted
teinté gris foncé
teñido gris oscuro



LC R08
tinto noce
walnut stain oak
teinté noyer
teñido nogal



LC R09
tinto tabacco
tobacco stain oak
teinté tabac
teñido tabaco



LC R10
tinto wengé
wengé stain oak
teinté wengue
teñido wengué

legno impiallacciato rovere laccato poro aperto fiammato vena verticale / oak veneered open pore lacquered with vertical grains
chêne plaqué pore ouvert veines verticales / roble enchapado lacado poro abierto vetas verticales



LD A01/A41
laccato opaco poro aperto
open pore mat lacquered
laqué mat pore ouvert
lacado mate poro abierto



LD A00
laccato Ral poro aperto
open pore lacquered Ral
laqué Ral pore ouvert
lacado Ral poro abierto



LD A99
laccato al campione poro aperto
open pore lacquered by sample
laqué pore ouvert à l'échantillon
lacado poro abierto sobre muestra

Finiture ante

Door finishes . Finitions des portes . Acabados puertas

LAMINATI / laminate / laminè / laminado

laminato b.p. / l.p. laminate / laminé b.p. / laminado b.p.

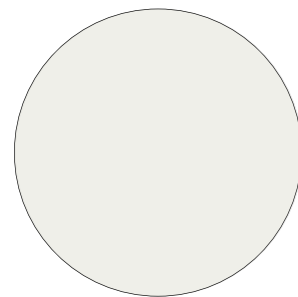

N3
bianco effetto seta



N4
rovere termico



N6
rovere lerici



N7
olmo grigio



N8
legno vintage



NZ
bronzo metallizzato

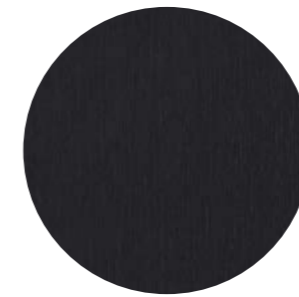

N0
antracite metallizzato



NPC
polo club



NCC
cricket club



NSC
ski club



ND
rovere San Remo white



N9
argilla

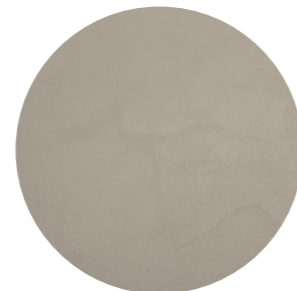

NA
platino



NB
cemento chiaro



NC
cemento scuro

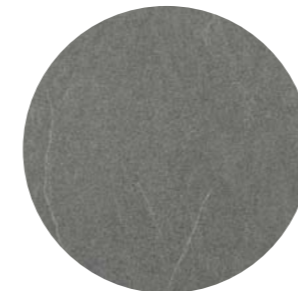

N37
concreta masieri

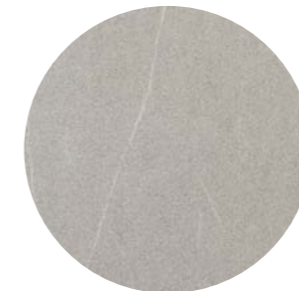

N38
concreta_bassi



NSS
spring



NKK
King



NPP
Paglia



NF
native oak light

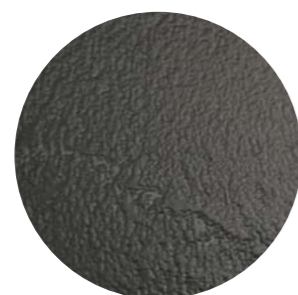

NG
basalt



NL
eiche sanremo tabacco



NM
grigio cobalto



NR
glauco



NRR
reflex

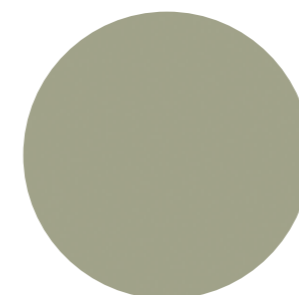

NVV
verde

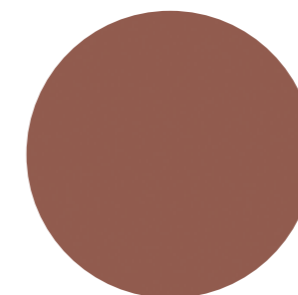

NAA
arancione



NS
landscape



NT
eclissi



NW
ciliegio penorte



NX
noce dozuky



NY
cemento bianco

Finiture ante

Door finishes . Finitions des portes . Acabados puertas

LAMINATI / laminate / laminè / laminado

laminato b.p. laccato supermatt / l.p. laminate Supermatt lacquered / laminè b.p. laquè Supermatt / laminado b.p. laccado Supermatt

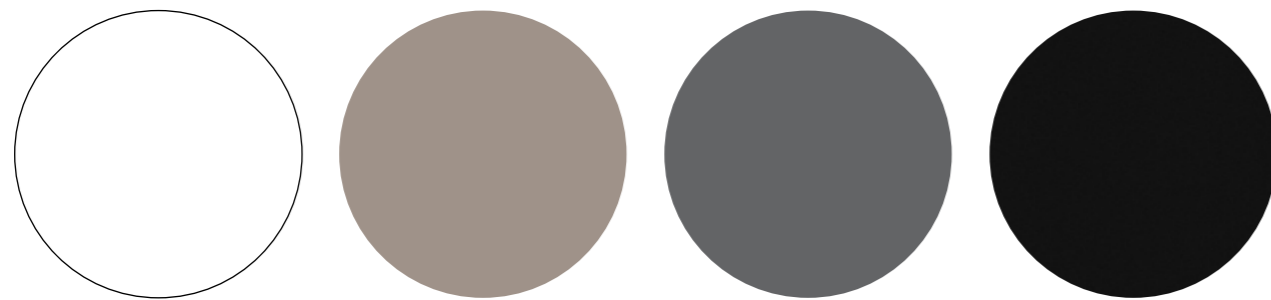

LSBI
bianco

LSFA
fango

LSGR
grigio

LSNE
nero

laminato b.p. rigato / ribbed l.p. laminate / laminé b.p. nervurée / laminado b.p. estriado

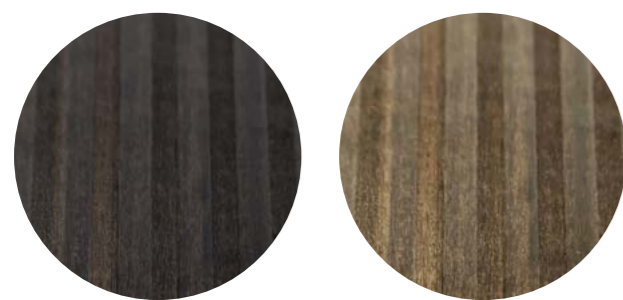

NP
rovere termico rigato
Ribbed heat-treated oak
Chêne thermo-traité nervurée
Roble tratado térmicamente estriado

NJ
noce rigato
Ribbed walnut
Noyer nervurée
Nogal estriado

LAMINATI / laminate / laminè / laminado

fenix



FXBK
bianco Kos

FXBM
bianco malè

FXBX
beige luxor

FXCT
castoro Ottawa

FXGL
grigio Londra



FXRJ
rosso jaipur

FXVC
verde Comodoro

FXBL
bluriva

FXGE
grigio Efeso

FXGB
grigio bromo



FXNI
nero ingo

FXGA
grigio antrim saten

FXBE
beige arizona saten

FXGR
grigio aragona

FXVK
verde kitami

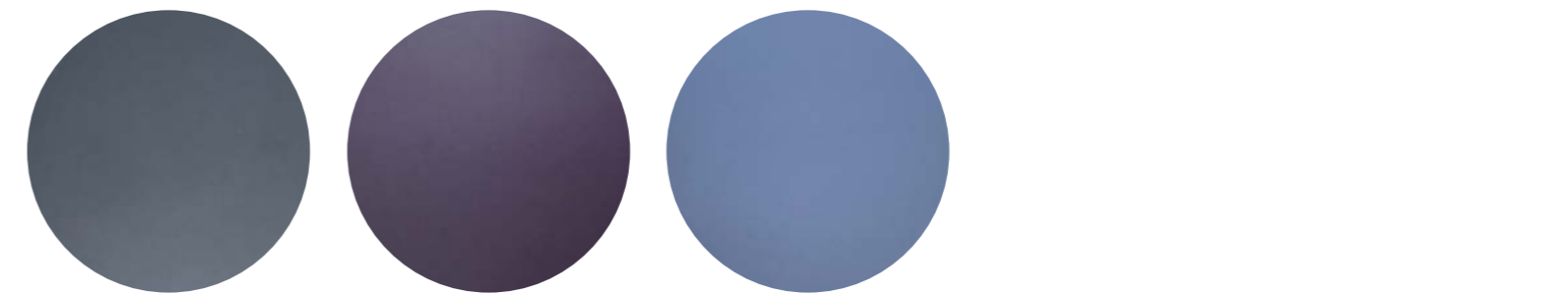

FXBS
blu shaba

FXVD
viola drissa

FXOD
azzurro naxos

Finiture ante

Door finishes . Finitions des portes . Acabados puertas

LACCATO OPACO - LACCATO LUCIDO / mat lacquered - glossy lacquered / laqué mat - laqué brillant / lacado mate - lacado brillante

laccato opaco / mat lacquered / laqué mat / lacado mate

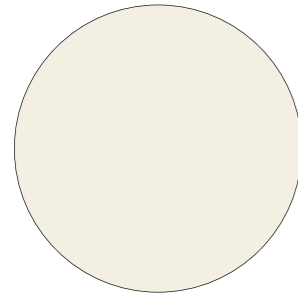

A01
bianco caldo / warm white
blanc chaud / blanco caliente

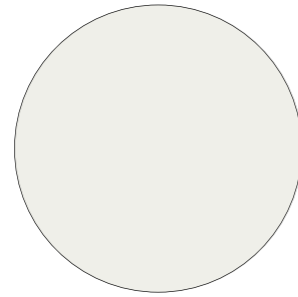

A02
bianco queen / queen white
blanc queen / blanco queen

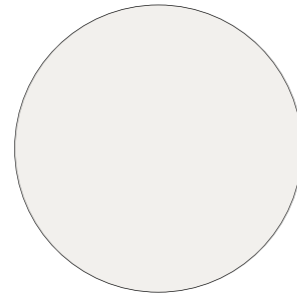

A03
calce / lime
chaux / cal

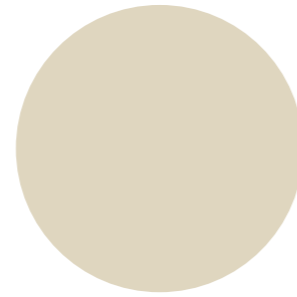

A04
canapa / hemp
chanvre / cáñamo

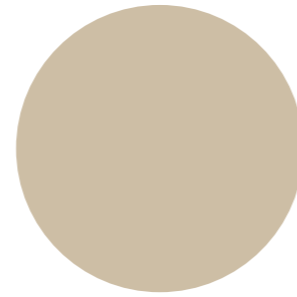

A06
argilla / clay
argile / arcilla

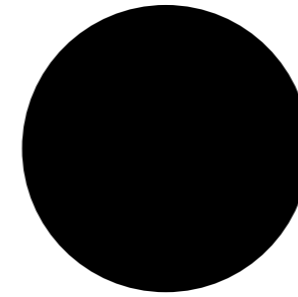

A33
nero / black
noir / negro

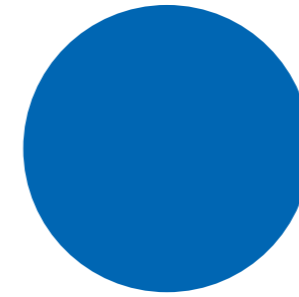

A20
blu scuro / dark blue
bleu foncé / azul oscuro

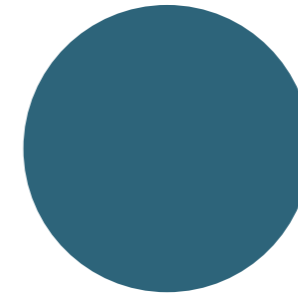

A22
blu china / china blue
bleu chine / azul china

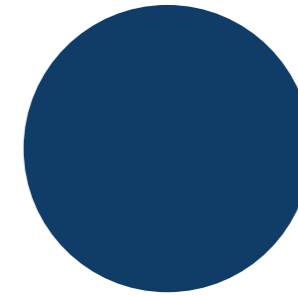

A21
blu notte / night blue
bleu nuit / azul noche

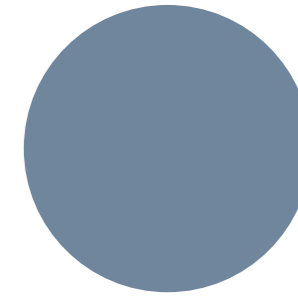

A38
carta da zucchero / mid-blue
bleu pastel / cian pálido

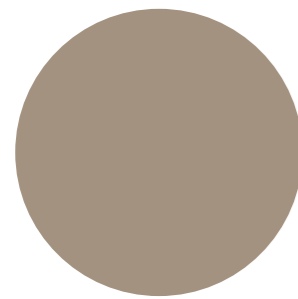

A07
beige / beige
beige / beige

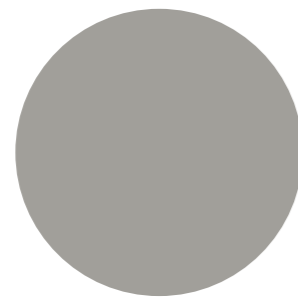

A08
platino / platinum
platine / platino

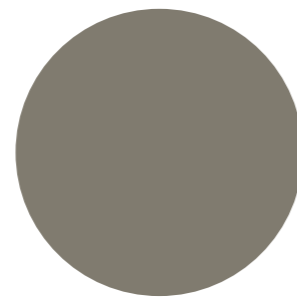

A09
tortora / dove grey
greige / tortola

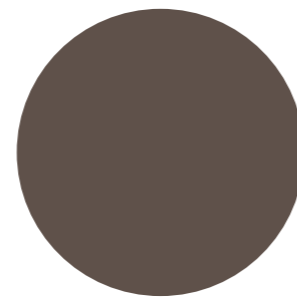

A26
marrone ciad / chad brown
marron tchad / marròn chad

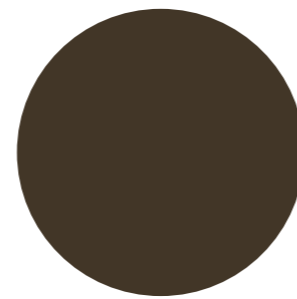

A27
caffè / coffee
café / café

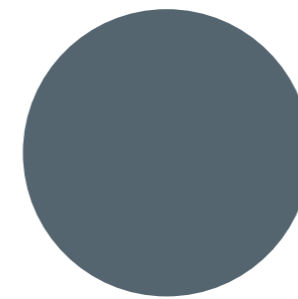

A39
petrolio / petroleum blue
bleu pétrole / azul petróleo

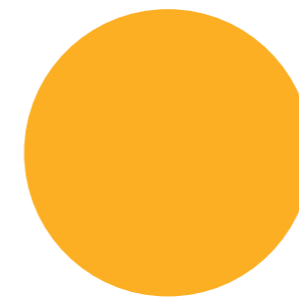

A11
giallo peperone / pepper yellow
jaune poutron / amarillo pimiento

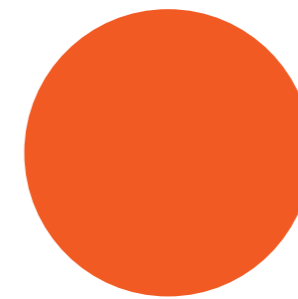

A13
arancio scuro / dark orange
orange foncé / naranja oscuro

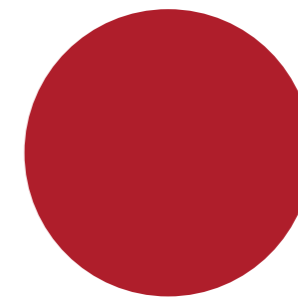

A14
rosso ginger / ginger red
rouge ginger / rojo ginger

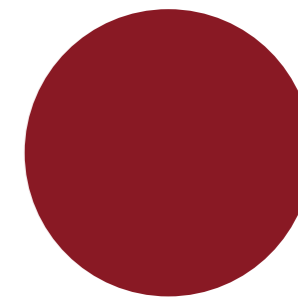

A15
rosso barolo / barolo red
rouge barolo / rojo barolo

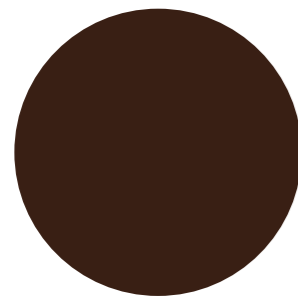

A28
cioccolato / chocolate
chocolat / chocolate

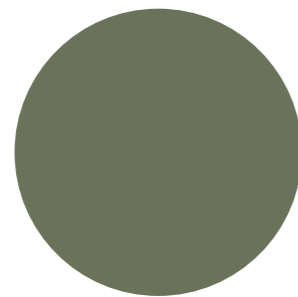

A24
verde muschio / musk green
vert musc / verde musgo

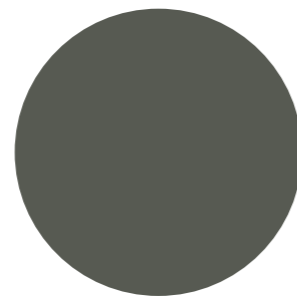

A25
verde palude / swamp green
vert marais / verde pantano

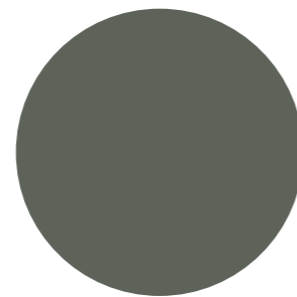

A34
roccia / rock
roche / roca

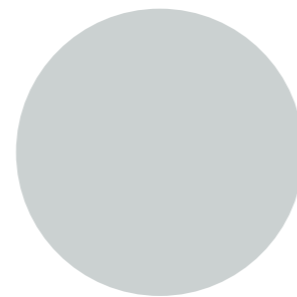

A35
ghiaccio / ice
glacier / hielo

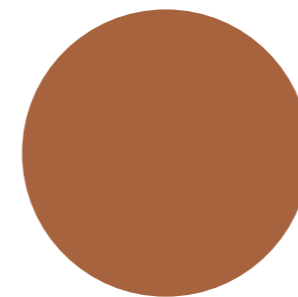

A40
terracotta / terracotta
terre cuite / terracota

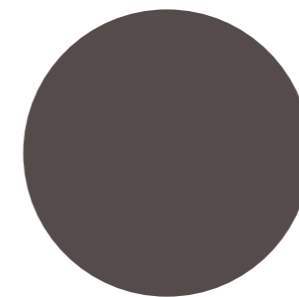

A41
piombo / lead
plomb / plomo



A00
Ral



A99
al campione / by sample
à l'échantillon / sobre muestra

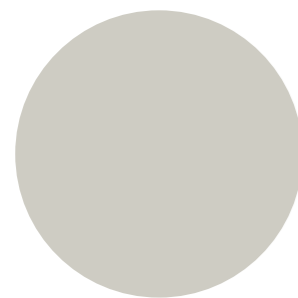

A30
grigio chiaro / light grey
gris clair / gris claro

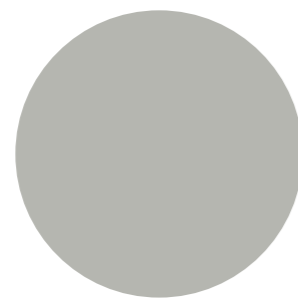

A31
grigio scuro / dark grey
gris foncé / gris oscuro

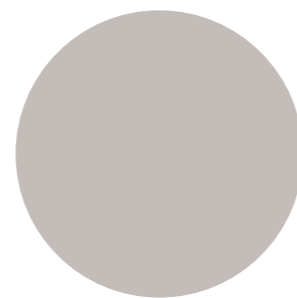

A32
grigio perla / pearl grey
gris perle / gris perla

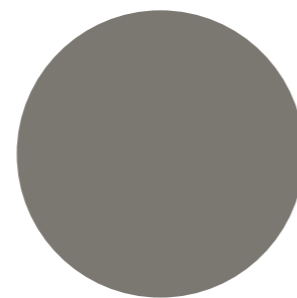

A36
grigio Londra / London Grey
gris Londres / gris Londres

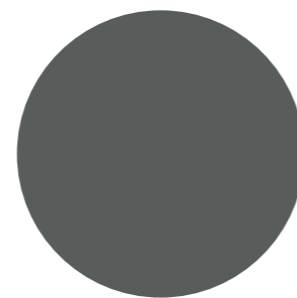

A37
antracite / anthracite
anthracite / antracita

Finiture ante

Door finishes . Finitions des portes . Acabados puertas

LACCATO OPACO / mat lacquered / laqué mat / lacado mate

finiture metallizzate / Metallic finishes / Finitions métalliques / Acabados metalizados

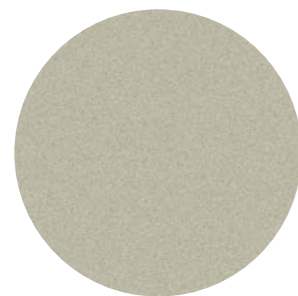

YCHA
champagne

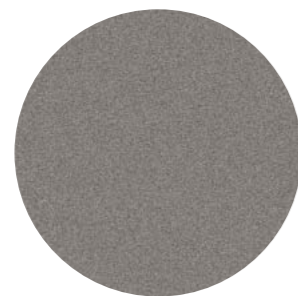

YBRO
bronzo

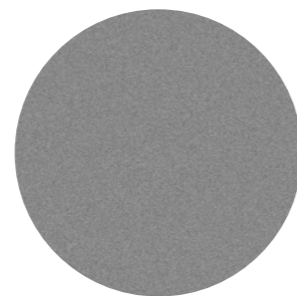

YGRF
grigio ferro

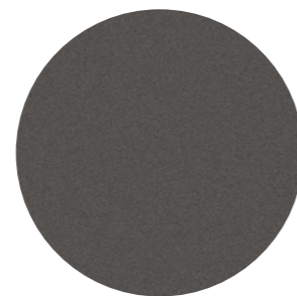

YANT
antracite

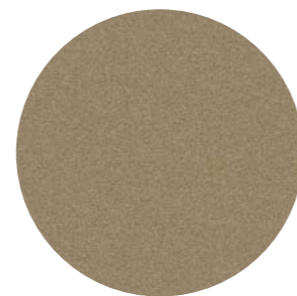

YORO
oro

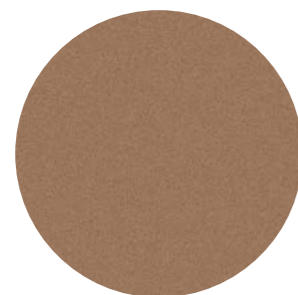

YRA2
rame

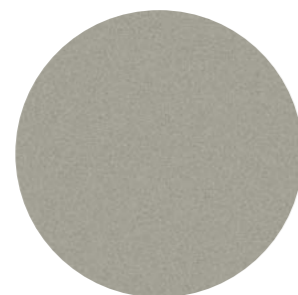

YT12
titanio

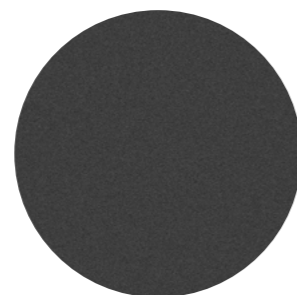

YNER
nero

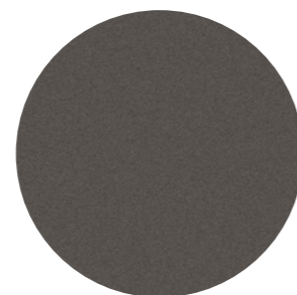

YMGR
metalgrey

laccato opaco textured / mat Textured Laquered / laqué Mat Texturé / lacado Mate Texturizado

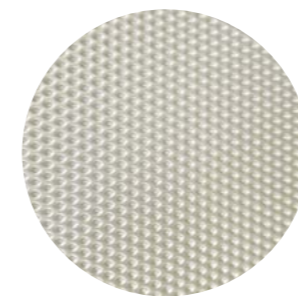

YCHA
champagne

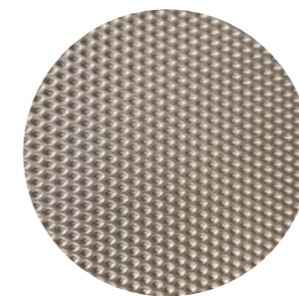

YBRO
bronzo

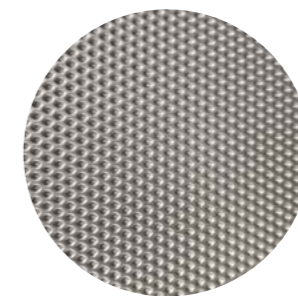

YGRF
grigio ferro

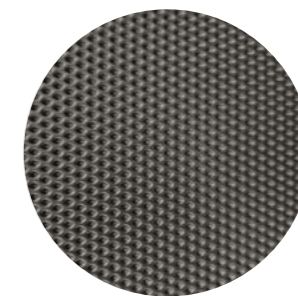

YANT
antracite

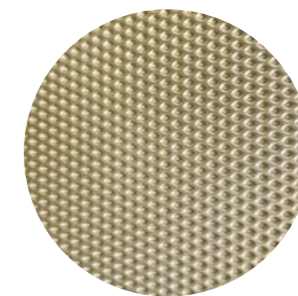

YORO
oro

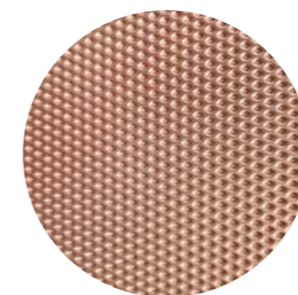

YRA2
rame

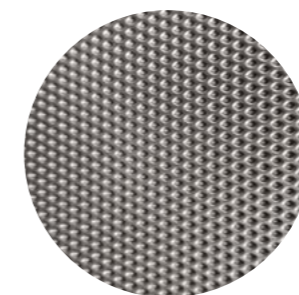

YT12
titanio

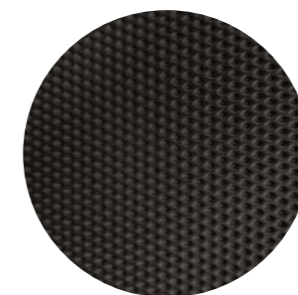

YNER
nero

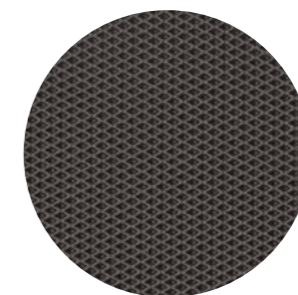

YMGR
metalgrey

Finiture ante

Door finishes . Finitions des portes . Acabados puertas

LACCATO OPACO / mat lacquered / laqué mat / lacado mate

laccato metallo effetto graffiato / scratched metal lacquered / laqué métallisé effet rayé / lacado metallizado efecto rayado

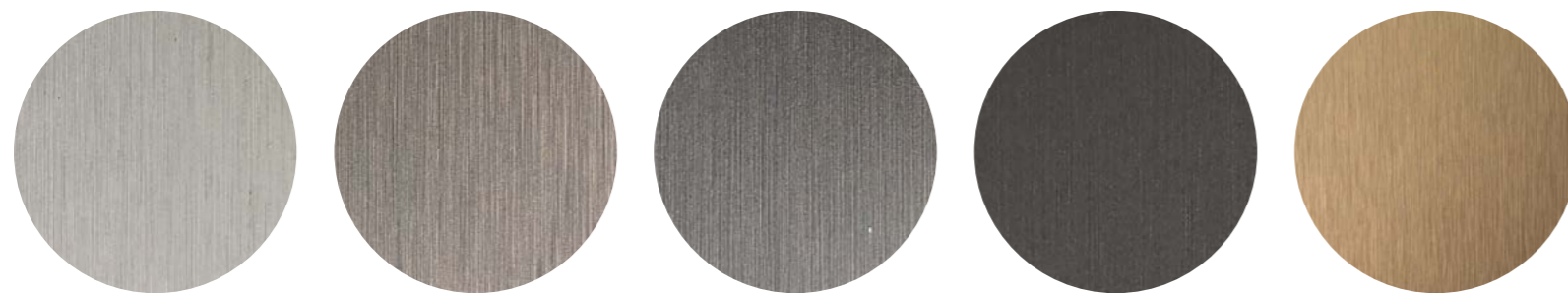

YCHA
champagne

YBRO
bronzo

YGRF
grigio ferro

YANT
antracite

YORO
oro



YRA2
rame



YT12
titanio



YNER
nero



YMGR
metalgrey

laccato speciale / special lacquered / laqué spécial / lacado especial



LAPS
peltro scuro



LAPN
peltro nero

VETRI / glass / verre / cristal

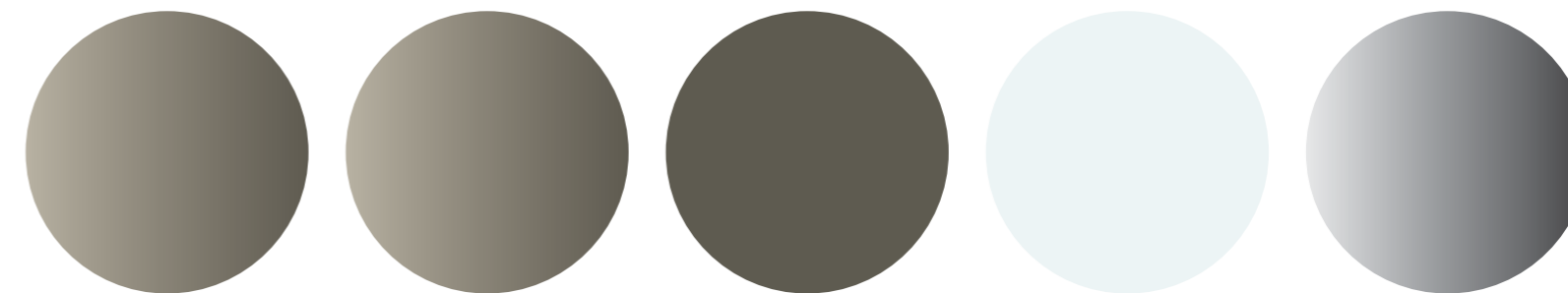

V1
bronzo riflettente
mirror-effect bronze
bronze effet miroir
bronze efecto espejo

V2
bronzo Stopsol
Stopsol bronze
bronze Stopsol
bronze Stopsol

V3
bronzo
bronze
bronze
bronze

V4
trasparente
transparent
transparent
transparente

V5
fumè grigio
smoke grey
gris fumè
ahumado



V7 A01/A41
satinato laccato
satin lacquered
laqué satiné
lacado satinado



V8 A01/A41
lucido laccato
glass lacquered
laqué brillant
lacado brillante



SP1
specchio
miroir
miroir
espejo

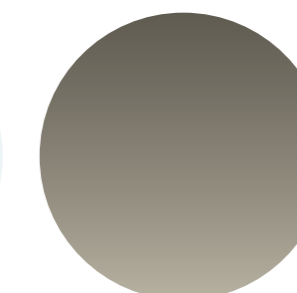

SP2
specchio bronzo
bronze mirror
miroir bronze
espejo bronze

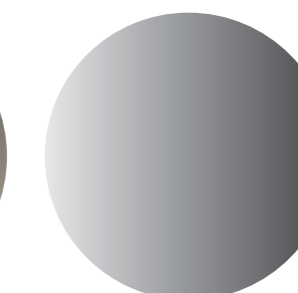

SP3
specchio fumè grigio
smoke grey mirror
miroir gris fumè
espejo ahumado



Composit srl
Strada Provinciale Fogliense, 41
Fraz. Montecchio
61022 Vallefoglia (PU)
Ph +39 0721 90971 ra
info@composit.it
www.composit.it

/

progetto grafico
Od'A design bernini cattaneo

digital image
Nudesign

post-production
Lifeinpixel

print
Gruppo Leardini

printed
febbraio 2025





